



# RENFROE

SPECIALIZING IN LIFTING SOLUTIONS



BLOCKS



CLAMPS



SHEAVES



ANCILLARY  
LIFTING  
PRODUCTS

## SERVING CUSTOMERS THROUGH...

- ▶ Manufacturing To Customized Specs
- ▶ Calls Answered By Company Service Representatives
- ▶ Quickship & Instock on Specified Products



November 2015  
Supersedes Catalog  
5COM123810

 **RENFROE**  
IT'LL TAKE A LOAD OFF YOUR MIND



# More up time. Less down time.

Reliability equals safety equals **less downtime** and more continuous workflow - any place where you need to lift, shift and move big weights. Be assured that all our products have to outperform the specification they were designed to meet; a solid fact that holds firm. That's why it's safe to say Renfroe products last longer.



J.C. Renfroe & Sons Jacksonville, Florida 32206 Toll Free 800.874.8454 • Fax 904.354.7865 • [www.jcrenfroe.com](http://www.jcrenfroe.com)



**J.C. Renfro & Sons has been an international leader in the manufacturing and marketing of lifting products for over 70 years.**

Corporate Headquarters  
Jacksonville, Florida  
Telephone: **904-356-4181**  
Toll Free: **1-800-874-8454**  
Fax: 904-354-7865  
[www.jcrenfroe.com](http://www.jcrenfroe.com)

**USA Plant Location**

**J.C. Renfro & Sons**  
1926 Spearing Street  
Jacksonville, Florida 32206

**Partnering Plants**

**Spain**  
**Germany**

**NOTICE OF EXCLUSION OF WARRANTY**

RENFROE HAS HEREIN SET FORTH IN CONSPICUOUS LANGUAGE AN EXCLUSION OF ANY WARRANTY EITHER EXPRESSED OR IMPLIED, WHICH IS NOT SPECIFICALLY AND PARTICULARLY CONTAINED HEREIN. PLEASE REFER TO THAT STATEMENT FOR REPRESENTATIONS AND WARRANTIES OF PRODUCTS MANUFACTURED BY J.C. RENFROE & SONS



# Table of Contents

Renfro Information	1
Table of Contents	2 & 3
The Renfro Story (history & plant photos)	4
Clamp Index	8
<b>Collage - Vertical Only Clamps</b>	<b>9</b>
BD	10
FR	11
FRD	12
R	13
RO	14
S	15
SD	16
<b>Collage - Vertical + 90</b>	<b>17</b>
J	18
L	19
LJ	20
TL	21
<b>Collage - Vertical 90 + Side Pull</b>	<b>22</b>
JP	23
LP	24
<b>Collage - Vertical + 180</b>	<b>25</b>
DC	26
JA	27
LA	28
PCK-SL	29
RSC	30
SCP	31
SCSL	32
SCSM	33
TLA	34
<b>Collage - Vertical + 180 + Side Pull</b>	<b>35</b>
JPA	36
LPA	37
SCPA	38
<b>Collage - Structural - Shapes</b>	<b>39</b>
AST	41
ASTL	42





AST-S	43	General Information	81
DG	44	Manuals and Rebuild Kits	82
M	45	Sheave Introduction	84
SEA	46	Sheave – Dimensions & Size Charts	85-89
SX	47	Model S Synthetic Sheaves	90
<b>Collage - Horizontal</b>	<b>48</b>	Bearings/Sales Policies/Definitions	91
DWS	49	Sheave Inquiry Sheet	92
HR	50	Sheave Order Form	93
HDR	51	Sheave Installation, Operation & Maintenance	94 & 95
HRS	52	Bridge Crane Block Capacities	97
M	53	Din Hook Block	98
WHSR	54	Mobile Crane Block Data	99-102
<b>Collage - Beam</b>	<b>55</b>	Block Maintenance & Inspection	103
A-1	56	Block Inquiry Order Form	104
AC	57	Block Operator Manual	105-111
ACP	58	Load Weighing Blocks	113
B-1	59	Load Weighing Block Data	114
B-2	60	Load Weighing Block – Single Sheave	115
BC	61	Load Weighing Block – 2 Sheave	116
PB	62	Load Weighing Block – Motorized Sheave	117
<b>Collage – Pull</b>	<b>63</b>	Load Weighing Block – 4 Sheave	118
PC	64	Snatch Block Features	120
<b>Collage – Non-Marring</b>	<b>65</b>	Snatch Block Dimensions	121
NM	66	Snatch Block Hook Assembly	122
NMA	67	Snatch Block Shackle Assembly	123
NMBL	68	Snatch Block Tailboard Assembly	124
NMRSC	69	Snatch Block Warning	125 & 126
<b>Collage – Drum Lifter</b>	<b>70</b>	Swivels	128
300-S	71	Swivel Part Numbers	129
400-M	72	Swivel Dimensions	130 & 131
<b>Collage – Tool</b>	<b>73</b>	Load Limiter	133
Tagline	75		
Pry Tool	76		
Product Testing	77		
Do's & Don'ts	78		
Definitions	79 & 80		



## J.C. RENFROE & SONS HAS BEEN A LEADER IN THE MANUFACTURING AND MARKETING OF LIFTING PRODUCTS FOR OVER 70 YEARS.

Renfro products are manufactured in Jacksonville, Florida and Germany. A world-wide network of stocking distributors provides a readily available source of supply and service.

We have a distinguished heritage at J.C. Renfro & Sons. When our country has called, we have responded. The historic Liberty Bell in Philadelphia, Pennsylvania, needed to be relocated with great care. Our lifting products were used. After the space shuttle Challenger tragedy, we were called to design a special clamp to aid in the recovery of the debris. When they needed lifting capabilities for our nuclear submarines, we were there. History has proven when our country needed the very best, Renfro was called.

The Renfro legacy began in 1940 with Joseph Renfro and his four sons. The standard of excellence on which the company was founded exists today with J.C. Renfro II, grandson of the founder, overseeing the final inspections of Renfro clamps.

Renfro's innovative technology and streamlined manufacturing produces the highest quality lifting products in the industry. Our close-knit employee family continues to work with the same dedication to excellence as our founders.





# J.C. RENFROE WORKS HARD TO EARN YOUR BUSINESS



## Our Delivery Systems Are Designed To Get Lifting Products To You When You Need Them

It is the goal of J.C. Renfroe to make the purchase and delivery of products as smooth and easy as possible. To help achieve that goal, we offer two time-sensitive delivery programs, Quickship and Instock, to help you prevent downtime on your projects.



**INSTOCK**  
designated  
products  
ship within  
48 hours.



**QUICKSHIP**  
designated  
products ship  
within 10  
business  
days

*Just look for our red Quickship logo or our green Instock logo on our products, in our catalogs and on our website.*

**↑ RENFROE**  
IT'LL TAKE A LOAD OFF YOUR MIND

J.C. Renfroe & Sons, Jacksonville, Florida 32206 USA • Toll Free 800.874.8454 • Fax 904.354.7885 • [www.jcrenfroe.com](http://www.jcrenfroe.com)



# Big or small, Renfroe has it all.

Whether it's big, small or somewhere in between, if your operation depends on using the right size lifting clamp for the job, you need a Renfroe clamp. That's because J.C. Renfroe has an extensive selection of products with many rated lifting capacities. We're so determined that you find the right model for your lifting needs that, if you can't find it from our line of clamps, we'll happily engineer one specially suited

to your application. We even offer free safety surveys and training seminars for our customers. That's what comes from being tuned into our customers' needs and wants for more than 65 years. It's no wonder that outstanding customer service and on-time deliveries rank right up there with our being able to offer you the best quality lifting clamp in the industry.

For more information on how we size up, contact us today for an on-the-spot consultation about your lifting needs.



**J.C. RENFROE & SONS**

*Giving Industry the Lift It Needs!*

Jacksonville, FL USA  
Fax 904-354-7865 • Toll-Free 800-874-8454

[www.jcrenfroe.com](http://www.jcrenfroe.com)



## Don't Gamble On Your Clamp's Maintenance History

**RFID** Enabled Clamps From J.C. Renfroe



Ask About J.C.  
Renfroe's **FREE**  
RFID Retrofit  
Program



J.C. Renfroe & Sons, the leading manufacturer and marketer of quality industrial lifting clamps for over 70 years, is now offering the option of RFID (radio frequency identification) enabled chips. The embedded chip offers the capability of accessing user-supplied data, including...

- Catalog specifications
- Use history
- Maintenance instructions
- In-service date & inspection records
- Maintenance updates
- Manufacturing and training contact information.

For your nearest distributor, call **1-800-874-8454**



**IT'LL TAKE A LOAD OFF YOUR MIND**

**J.C. Renfroe & Sons, Jacksonville, Florida 32206 • Toll Free 800.874.8454 • Fax 904.354.7865 • [www.jcrenfroe.com](http://www.jcrenfroe.com)**



# CLAMP INDEX

## Model

### PLATE AND FABRICATED – VERTICAL ONLY

BD	Non-Locking Type	<b>10</b>
FR	Locking Type	<b>11</b>
FRD	Locking Type	<b>12</b>
R	Locking Type	<b>13</b>
RO	Non-Locking Type	<b>14</b>
S	Locking Type	<b>15</b>
SD	Locking Type	<b>16</b>

### VERTICAL + 90

J	Locking Type	<b>18</b>
L	Locking Type	<b>19</b>
LJ	Locking Type	<b>20</b>
TL	Locking Type	<b>21</b>

### VERTICAL + 90 + SIDE PULL

JP	Locking Type	<b>23</b>
LP	Locking Type	<b>24</b>

### VERTICAL + 180

DC	Locking Type	<b>26</b>
JA	Locking Type	<b>27</b>
LA	Locking Type	<b>28</b>
PCK-SL	Locking, Screw Type	<b>29</b>
RSC	Locking, Screw Type	<b>30</b>
SCP	Locking, Screw Type	<b>31</b>
SCSL	Locking, Screw Type	<b>32</b>
SCSM	Locking, Screw Type	<b>33</b>
TLA	Locking Type	<b>34</b>

### VERTICAL + 180 + SIDE PULL

JPA	Locking Type	<b>36</b>
LPA	Locking Type	<b>37</b>
SCPA	Locking, Screw Type	<b>38</b>

### STRUCTURAL – SHAPES

AST	Non-Locking Type	<b>41</b>
ASTL	Non-Locking Type	<b>42</b>
AST-S	Locking Type	<b>43</b>
DG	Locking Type	<b>44</b>
M	Locking Type	<b>45</b>
SEA	Locking Type	<b>46</b>
SX	Locking Type	<b>47</b>

### HORIZONTAL

DWS	Locking Type	<b>49</b>
HR	Non-Locking Type	<b>50</b>
HDR	Non-Locking Type	<b>51</b>
HRS	Locking Type	<b>52</b>
M	Locking Type	<b>53</b>
WHSR	Non-Locking Type	<b>54</b>

### BEAM

A-1	Locking Type	<b>56</b>
AC	Locking, Screw Type	<b>57</b>
ACP	Locking, Screw Type	<b>58</b>
B-1	Locking Type	<b>59</b>
B-2	Trolley Clamp	<b>60</b>
BC	Locking Type	<b>61</b>
PB	Locking Type	<b>62</b>

### PULL

PC	Locking, Screw Type	<b>64</b>
----	---------------------	-----------

### NON-MARRING

NM	Locking, Screw Type	<b>66</b>
NMA	Locking Type	<b>67</b>
NMBL	Locking Type	<b>68</b>
NMRSC	Locking, Screw Type	<b>69</b>

### DRUM LIFTERS – Vertical Only

300-S	Locking Type	<b>72</b>
400-M	Locking Type	<b>73</b>

### TOOL

Tagline	Tool Clamp	<b>75</b>
Pry Tool	Tool	<b>76</b>

# PLATE AND FABRICATED - VERTICAL ONLY



# Model BD Non-Locking Type

The **Model BD** is a vertical lifting, non-locking clamp used primarily for steel warehousing and bench work where a locking type clamp is not essential. The clamp is a low-cost, low maintenance tool that features lightweight and compact size. It is recommended for use and application where constant tension is applied to the lifting shackle throughout the entire operation.



## MODEL BD EXPLODED VIEW

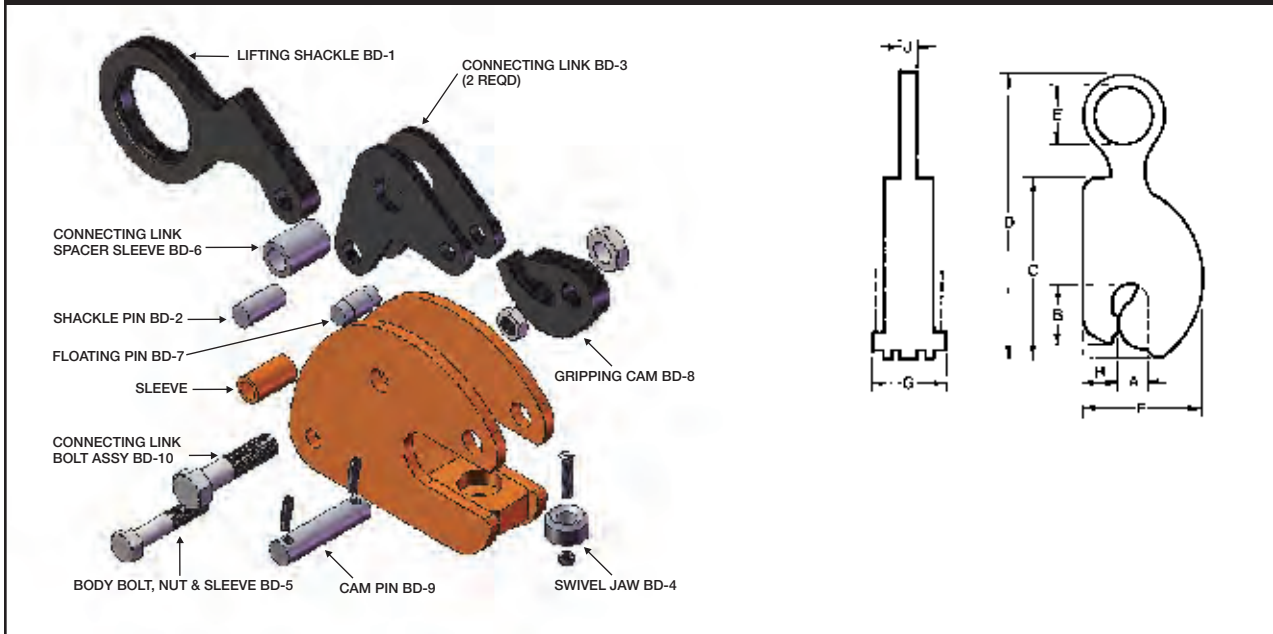

**SPECIFICATIONS** (in inches)

Rated Capacity Tons	Plate Thickness A	MAX. B	C	D	E	F	G	H	Weight J	(in pounds)
1/2	0-1	2 <sup>9</sup> / <sub>16</sub>	6 <sup>5</sup> / <sub>16</sub>	10 <sup>3</sup> / <sub>8</sub>	1 <sup>3</sup> / <sub>4</sub>	4 <sup>1</sup> / <sub>2</sub>	2 <sup>1</sup> / <sub>4</sub>	1 <sup>3</sup> / <sub>8</sub>	1 <sup>1</sup> / <sub>2</sub>	6
1	0-1 <sup>1</sup> / <sub>8</sub>	3 <sup>1</sup> / <sub>16</sub>	7 <sup>5</sup> / <sub>16</sub>	12 <sup>3</sup> / <sub>4</sub>	2 <sup>1</sup> / <sub>2</sub>	5 <sup>9</sup> / <sub>16</sub>	2 <sup>7</sup> / <sub>8</sub>	1 <sup>5</sup> / <sub>8</sub>	5 <sup>5</sup> / <sub>8</sub>	11
2	0-1 <sup>3</sup> / <sub>8</sub>	3 <sup>9</sup> / <sub>16</sub>	8 <sup>1</sup> / <sub>16</sub>	14 <sup>1</sup> / <sub>2</sub>	3 <sup>1</sup> / <sub>8</sub>	6 <sup>9</sup> / <sub>16</sub>	3	2 <sup>1</sup> / <sub>4</sub>	5 <sup>5</sup> / <sub>8</sub>	16
4	0-1 <sup>3</sup> / <sub>4</sub>	3 <sup>7</sup> / <sub>8</sub>	10 <sup>3</sup> / <sub>4</sub>	17 <sup>3</sup> / <sub>4</sub>	3 <sup>1</sup> / <sub>8</sub>	7 <sup>7</sup> / <sub>16</sub>	3 <sup>3</sup> / <sub>8</sub>	2 <sup>1</sup> / <sub>4</sub>	3 <sup>3</sup> / <sub>4</sub>	27
7	1 <sup>1</sup> / <sub>4</sub> -2 <sup>1</sup> / <sub>2</sub>	5	12 <sup>3</sup> / <sub>4</sub>	22 <sup>1</sup> / <sub>2</sub>	3 <sup>7</sup> / <sub>8</sub>	9 <sup>5</sup> / <sub>8</sub>	5	3	1	65

SPECIFICATIONS ARE SUBJECT TO CHANGE WITHOUT NOTICE.



## Model FR Locking Type

The **Model FR** is a vertical lifting tool for relatively light work. It is small and easy to handle in capacities through three tons. It incorporates a “Lock Closed” feature which facilitates attaching the clamp to the plate.

### MODEL FR EXPLODED VIEW

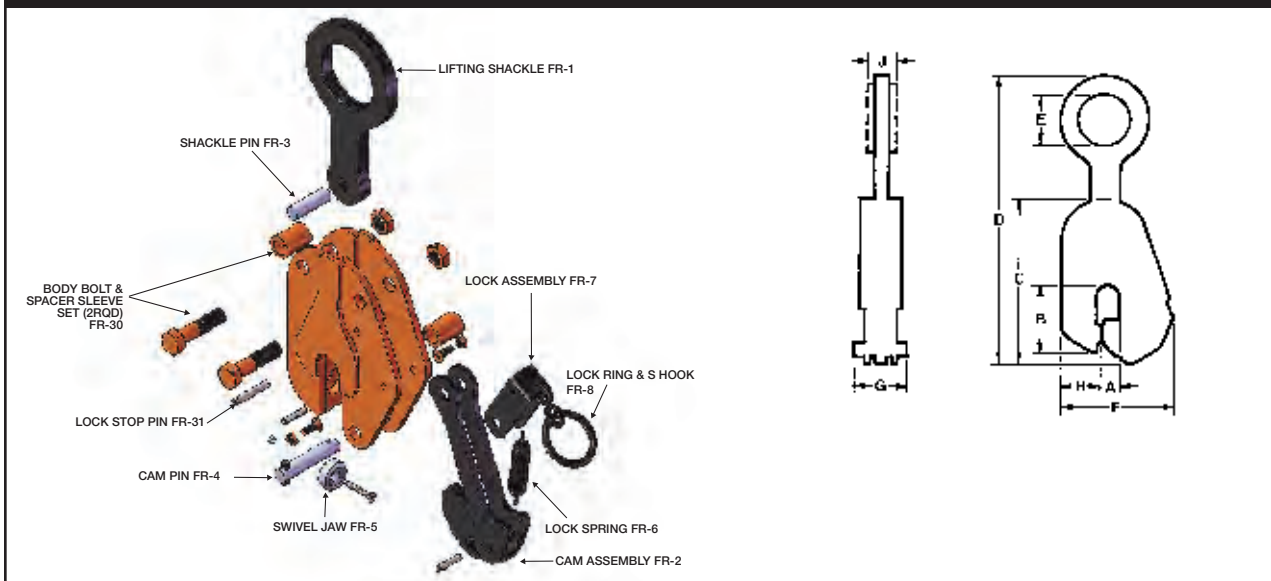

### SPECIFICATIONS (in inches)

Rated Capacity Tons	Plate Thickness A	B	C	MAX. D	E	F	G	H	J	Weight (in pounds)
1/2	0-3/4	2 13/16	7	11 1/4	2 3/8	4 5/8	2 1/2	1 1/2	1/2	8
	1/2-1	2 13/16	7	11 1/4	2 3/8	4 5/8	2 1/2	1 1/2	1/2	8
	3/4-1 1/4	2 13/16	7	11 1/4	2 3/8	5 1/8	2 1/2	1 1/2	1/2	9
	1-1 1/2	2 13/16	7	11 1/4	2 3/8	5 3/8	2 1/2	1 1/2	1/2	10
	1 1/4-1 3/4	2 13/16	7	11 1/4	2 3/8	5 3/8	2 1/2	1 1/2	1/2	11
1	0-3/4	3 3/16	9	13 3/4	2 5/8	5 5/8	3 3/16	1 5/8	5/8	14
	1/2-1	3 3/16	9	13 3/4	2 5/8	6 1/8	3 3/16	1 5/8	5/8	15
	3/4-1 1/4	3 3/16	9	13 3/4	2 5/8	6 3/8	3 3/16	1 5/8	5/8	15
	1-1 1/2	3 3/16	9	13 3/4	2 5/8	6 5/8	3 3/16	1 5/8	5/8	16
	1 1/4-1 3/4	3 3/16	9	13 3/4	2 5/8	6 3/4	3 3/16	1 5/8	5/8	17
1 1/2-2	3 3/16	9	13 3/4	2 5/8	7 1/8	3 3/16	1 5/8	5/8	18	
2	0-1	3 1/2	9	16 3/8	3 5/8	6 3/4	3 3/8	2 1/8	3/4	23
	3/4-1 1/2	3 1/2	9	16 3/8	3 5/8	7 1/4	3 3/8	2 1/8	3/4	23
	1 1/4-2	3 1/2	9	16 3/8	3 5/8	7 3/4	3 3/8	2 1/8	3/4	23
	1 3/4-2 1/2	3 1/2	9	16 3/8	3 5/8	8 1/4	3 3/8	2 1/8	3/4	24
3	0-1 1/4	4 3/16	10 3/4	18 3/8	3 5/8	7 5/8	3 9/16	2 7/16	3/4	30
	3/4-1 1/2	4 3/16	10 3/4	18 3/8	3 5/8	7 7/8	3 9/16	2 7/16	3/4	31
	1 1/4-2	4 3/16	10 3/4	18 3/8	3 5/8	8 3/8	3 9/16	2 7/16	3/4	32
	1 3/4-2 1/2	4 3/16	10 3/4	18 3/8	3 5/8	8 7/8	3 9/16	2 7/16	3/4	33

SPECIFICATIONS ARE SUBJECT TO CHANGE WITHOUT NOTICE.



# Model FRD Locking Type



The **Model FRD** is a vertical lifting clamp that incorporates two Model FR clamps into one and is used for heavy duty work where it is desirable to spread the gripping surfaces with two points of contact. The clamp contains two “Lock Closed” mechanisms which are activated by a single chain and a manually operated “Lock Open” mechanism.

## MODEL FRD EXPLODED VIEW

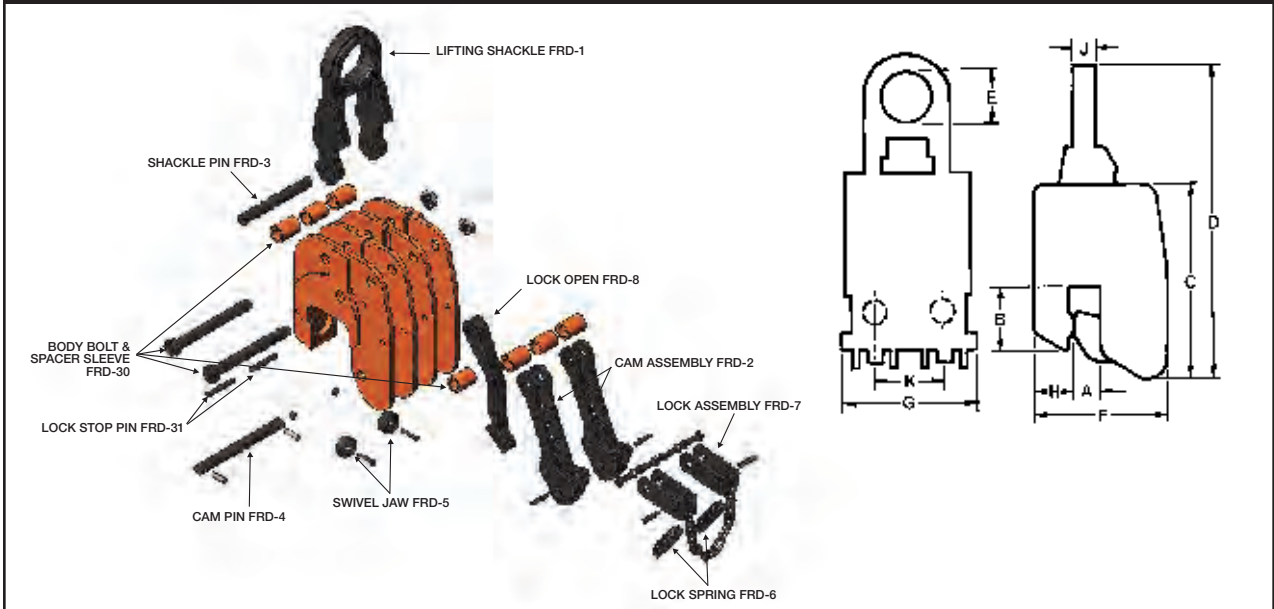

### SPECIFICATIONS (in inches)

Rated Capacity Tons	Plate Thickness A	B	C	MAX. D	E	F	G	H	I	J	Weight (in pounds)
<b>1</b>	0- $\frac{3}{8}$	2 $\frac{5}{8}$	7 $\frac{3}{4}$	14	2 $\frac{3}{8}$	4 $\frac{3}{4}$	5 $\frac{1}{2}$	1 $\frac{1}{2}$	$\frac{5}{8}$	3	16
	0- $\frac{3}{4}$	2 $\frac{5}{8}$	7 $\frac{3}{4}$	14	2 $\frac{5}{8}$	5 $\frac{1}{8}$	5 $\frac{1}{2}$	1 $\frac{1}{2}$	$\frac{5}{8}$	3	18
	$\frac{3}{4}$ -1 $\frac{1}{4}$	2 $\frac{5}{8}$	7 $\frac{3}{4}$	14	2 $\frac{3}{8}$	5 $\frac{5}{8}$	5 $\frac{1}{2}$	1 $\frac{1}{2}$	$\frac{5}{8}$	3	20
	1 $\frac{1}{4}$ -1 $\frac{3}{4}$	2 $\frac{5}{8}$	7 $\frac{3}{4}$	14	2 $\frac{3}{8}$	5 $\frac{5}{8}$	5 $\frac{1}{2}$	1 $\frac{1}{2}$	$\frac{5}{8}$	3	24
<b>2</b>	0- $\frac{3}{4}$	3 $\frac{1}{16}$	9	15 $\frac{3}{8}$	2 $\frac{1}{2}$	6	6 $\frac{1}{2}$	1 $\frac{5}{8}$	$\frac{3}{4}$	3 $\frac{1}{8}$	26
	$\frac{3}{4}$ -1 $\frac{1}{4}$	3 $\frac{1}{16}$	9	15 $\frac{3}{8}$	2 $\frac{1}{2}$	6 $\frac{1}{2}$	6 $\frac{1}{2}$	1 $\frac{5}{8}$	$\frac{3}{4}$	3 $\frac{1}{8}$	30
	1 $\frac{1}{4}$ -1 $\frac{3}{4}$	3 $\frac{1}{16}$	9	15 $\frac{3}{8}$	2 $\frac{1}{2}$	7	6 $\frac{1}{2}$	1 $\frac{5}{8}$	$\frac{3}{4}$	3 $\frac{1}{8}$	34
<b>4</b>	0-1	3 $\frac{1}{2}$	9 $\frac{7}{16}$	17 $\frac{3}{4}$	2 $\frac{7}{8}$	6 $\frac{5}{16}$	6 $\frac{3}{4}$	2 $\frac{1}{8}$	$\frac{3}{4}$	3 $\frac{5}{8}$	40
	1-1 $\frac{1}{4}$	3 $\frac{1}{2}$	9 $\frac{7}{16}$	17 $\frac{3}{4}$	2 $\frac{7}{8}$	7 $\frac{1}{16}$	6 $\frac{3}{4}$	2 $\frac{1}{8}$	$\frac{3}{4}$	3 $\frac{5}{8}$	44
	1 $\frac{3}{4}$ -2 $\frac{1}{2}$	3 $\frac{1}{2}$	9 $\frac{7}{16}$	17 $\frac{3}{4}$	2 $\frac{7}{8}$	7 $\frac{13}{16}$	6 $\frac{3}{4}$	2 $\frac{1}{8}$	$\frac{3}{4}$	3 $\frac{5}{8}$	48
<b>6</b>	0-1 $\frac{3}{8}$	4 $\frac{1}{8}$	11 $\frac{1}{2}$	20 $\frac{5}{8}$	3 $\frac{3}{16}$	7	7 $\frac{7}{8}$	2	1 $\frac{3}{8}$	4 $\frac{1}{8}$	58
	1 $\frac{3}{8}$ -2 $\frac{1}{2}$	4 $\frac{1}{8}$	11 $\frac{1}{2}$	20 $\frac{5}{8}$	3 $\frac{3}{16}$	8 $\frac{1}{8}$	7 $\frac{7}{8}$	2	1 $\frac{3}{8}$	4 $\frac{1}{8}$	67
	2 $\frac{1}{2}$ -3 $\frac{5}{8}$	4 $\frac{1}{8}$	11 $\frac{1}{2}$	20 $\frac{5}{8}$	3 $\frac{3}{16}$	9 $\frac{1}{4}$	7 $\frac{7}{8}$	2	1 $\frac{3}{8}$	4 $\frac{1}{8}$	66

SPECIFICATIONS ARE SUBJECT TO CHANGE WITHOUT NOTICE.





# Model R Locking Type

The **Model R** is a vertical lifting clamp primarily used in the handling of heavy steel plate in a wide range of plate thicknesses. Specific models are available for handling “hot” plate (refer to factory for maximum temperatures and recommended application).

The **Model R** incorporates a “Lock Open,” “Lock Closed” feature which facilitates attaching and removing the clamp from the plate.

## MODEL R EXPLODED VIEW

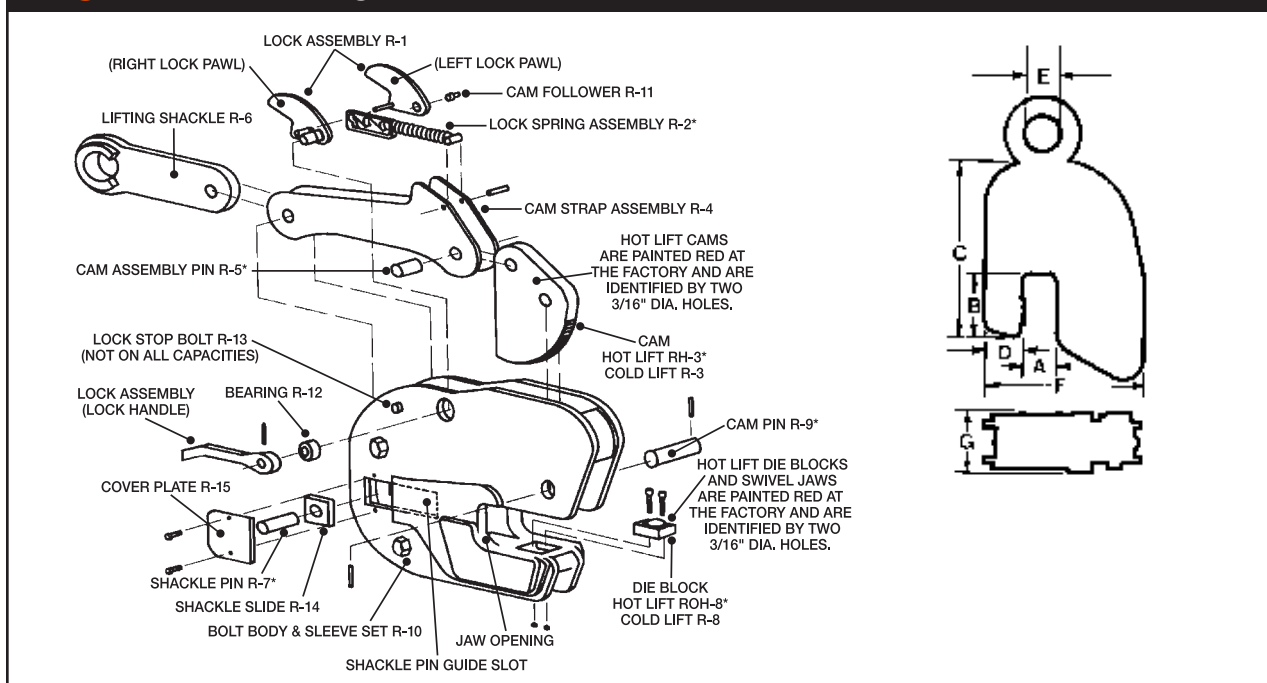

PLATE AND FABRICATED – VERTICAL ONLY

### SPECIFICATIONS (in inches)

Rated Capacity Tons	Plate Thickness A	B	C	D	E	F	Weight	
							G	(in pounds)
35	¼-4¼	8 <sup>3</sup> / <sub>8</sub>	23 <sup>5</sup> / <sub>8</sub>	5 <sup>1</sup> / <sub>16</sub>	5	21 <sup>3</sup> / <sub>8</sub>	8	470
	4-8	8 <sup>3</sup> / <sub>8</sub>	23 <sup>5</sup> / <sub>8</sub>	5 <sup>1</sup> / <sub>16</sub>	5	25 <sup>1</sup> / <sub>8</sub>	8	515
50	½-6½	13	44 <sup>3</sup> / <sub>4</sub>	9	5	36	13½	1370
	6-12	13	44 <sup>3</sup> / <sub>4</sub>	9	5	41½	13½	1500
75	½-6½	16½	46 <sup>3</sup> / <sub>4</sub>	14¼	11	42½	12½	2700
	3-9	16½	46 <sup>3</sup> / <sub>4</sub>	14¼	11	45	12½	2775
	6-12	16½	46 <sup>3</sup> / <sub>4</sub>	14¼	11	48	12½	2850
	8-14	16½	46 <sup>3</sup> / <sub>4</sub>	14¼	11	50	12½	2900

SPECIFICATIONS ARE SUBJECT TO CHANGE WITHOUT NOTICE.



# Model RO

## Non-Locking Type

The **Model RO** incorporates a “Lock Open Only” feature allowing the clamp to be “Locked Open,” lifted onto a “hot” plate and the lock released without the operator coming in close contact with the “hot” plate.

### MODEL RO EXPLODED VIEW

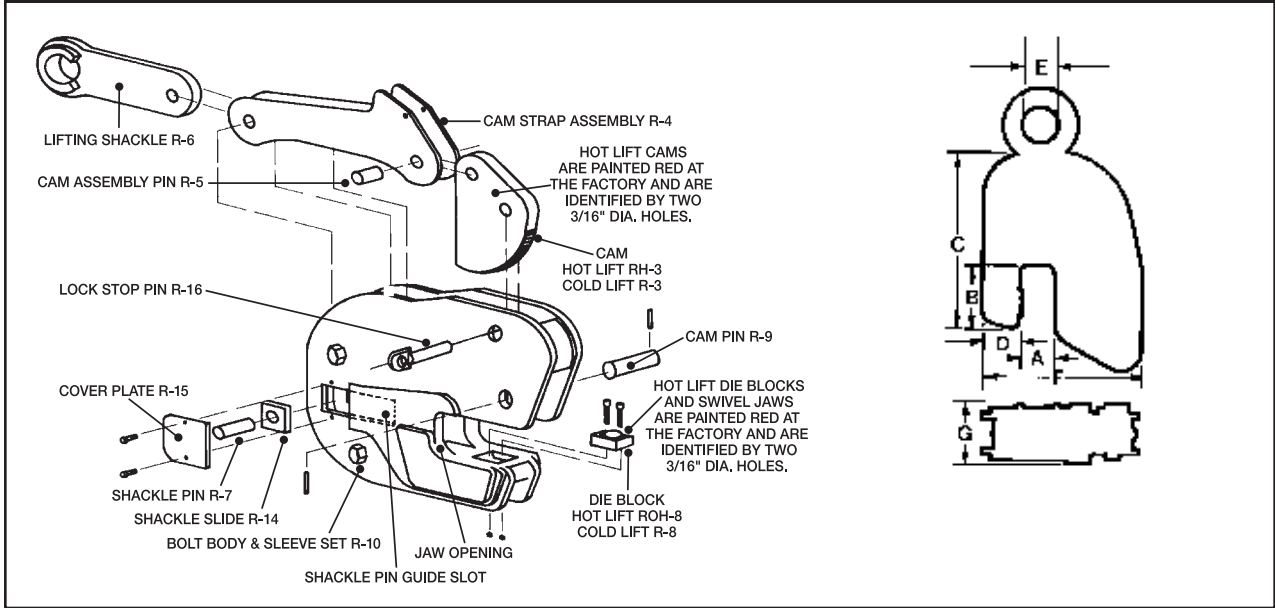

**SPECIFICATIONS** (in inches)

Rated Capacity Tons	Plate Thickness A	B	C	D	E	F	Weight	
							G	(in pounds)
<b>35</b>	¼-4¼	8¾	23½	5¼	5	21¾	8	470
	4-8	8¾	23½	5¼	5	25½	8	515
<b>50</b>	½-6½	13	44¾	9	5	36	13½	1370
	6-12	13	44¾	9	5	41½	13½	1500
<b>75</b>	½-6½	16½	46¾	14¼	11	42½	12½	2700
	3-9	16½	46¾	14¼	11	45	12½	2775
	6-12	16½	46¾	14¼	11	48	12½	2850
	8-14	16½	46¾	14¼	11	50	12½	2900

SPECIFICATIONS ARE SUBJECT TO CHANGE WITHOUT NOTICE.



## Model S Locking Type

The **Model S** is a vertical lifting clamp and is an effective tool for construction and erection. It incorporates a “Lock Open,” “Lock Closed” feature which facilitates attaching and removing the clamp from the plate.

### MODEL S EXPLODED VIEW

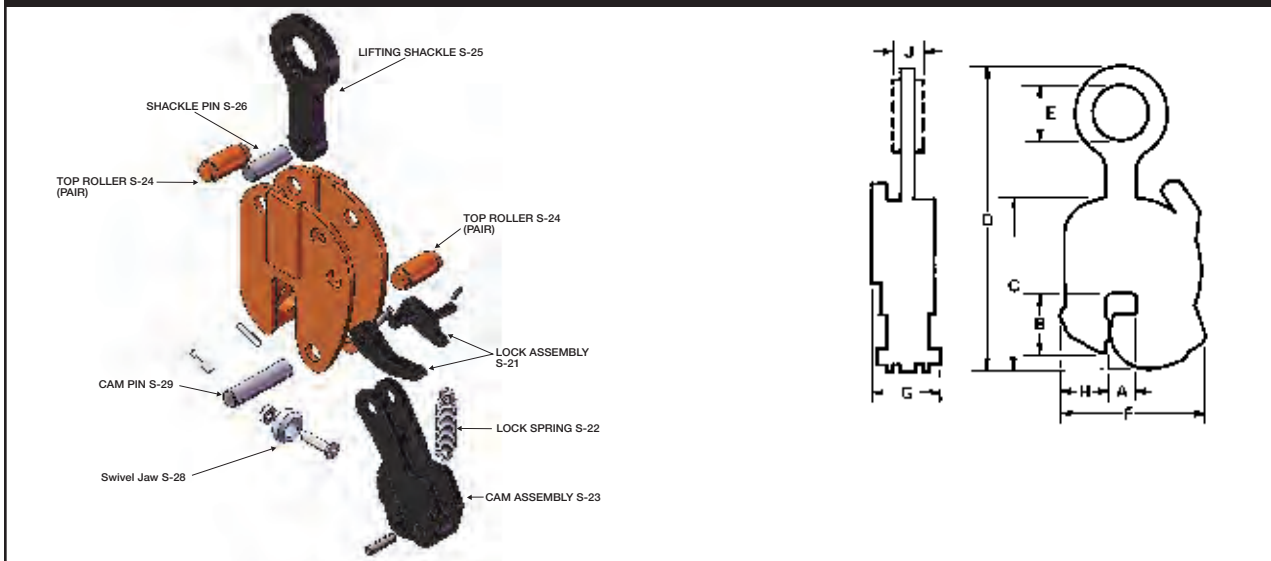

#### SPECIFICATIONS (in inches)

Rated Capacity Tons	Plate Thickness A	B	C	MAX. D	E	F	G	H	J	Weight (in pounds)
1/2	0-5/8	2	5 1/16	7 1/2	1 1/8	4 1/4	2 1/8	1 1/4	3/8	4
1	0-3/4	2	5 1/8	7 3/4	1 1/8	4 3/8	2 3/16	1 3/8	1/2	5
2	0-1	3 7/16	10	17	3 5/8	8 1/2	3 13/16	2 3/4	3/4	32
	3/4-1 1/2	3 7/16	10	17	3 5/8	9	3 13/16	2 3/4	3/4	33
	1 1/4-2	3 7/16	10	17	3 5/8	9 1/2	3 13/16	2 3/4	3/4	33
	1 3/4-2 1/2	3 7/16	10	17	3 5/8	10	3 13/16	2 3/4	3/4	36
4	0-1 1/4	4 5/8	11 1/2	19 5/8	3 5/8	10	4 7/8	3 3/16	3/4	41
	1-2	4 5/8	11 1/2	19 5/8	3 5/8	10 3/4	4 7/8	3 3/16	3/4	43
	1 3/4-2 3/4	4 5/8	11 1/2	19 5/8	3 5/8	11 1/2	4 7/8	3 3/16	3/4	43
	2 1/2-3 1/2	4 5/8	11 1/2	19 5/8	3 5/8	12 1/4	4 7/8	3 3/16	3/4	52
	3 1/4-4 1/4	4 5/8	11 1/2	19 5/8	3 5/8	13	4 7/8	3 3/16	3/4	60
8	0-1 1/2	4 1/2	13 15/16	22 1/2	3 3/4	10 1/2	5 1/8	3 5/16	1	70
	1-2	4 1/2	13 15/16	22 1/2	3 3/4	11	5 1/8	3 5/16	1	73
	2-3	4 1/2	13 15/16	22 1/2	3 3/4	12	5 1/8	3 5/16	1	77
	2 3/4-4	4 1/2	13 15/16	22 1/2	3 3/4	13	5 1/8	3 5/16	1	81
	3 3/4-5	4 1/2	13 15/16	22 1/2	3 3/4	14	5 1/8	3 5/16	1	85
12	0-2 1/2	6 1/2	18	28	3 3/8	13 1/2	6 1/4	3 7/8	1 1/4	140
	1/2-3	6 1/2	18	28	3 3/8	14	6 1/4	3 7/8	1 1/4	140
	2-4	6 1/2	18	28	3 3/8	15	6 1/4	3 7/8	1 1/4	143
	4-6	6 1/2	18	28	3 3/8	17	6 1/4	3 7/8	1 1/4	150
	5 1/2-7 1/2	6 1/2	18	28	3 3/8	18 1/2	6 1/4	3 7/8	1 1/4	160
20	1/2-3	7 1/2	22 3/4	35	4 15/16	17	7 3/8	5	2 1/2	265
	3-5	7 1/2	22 3/4	35	4 15/16	19	7 3/8	5	2 1/2	294
	5-7	7 1/2	22 3/4	35	4 15/16	21	7 3/8	5	2 1/2	324
	7-9	7 1/2	22 3/4	35	4 15/16	23	7 3/8	5	2 1/2	350
50*	1/2-3	8 3/8	27 5/8	41	4 5/8	22	9 3/4	6 5/8	3	470
100*	1/2-3	13 1/2	34	44	4 15/16	26	12 1/2	10 1/2	4	1350

SPECIFICATIONS ARE SUBJECT TO CHANGE WITHOUT NOTICE. OTHER CAPACITIES AVAILABLE UPON REQUEST.

\*For handling heavy plate or hot material, see Model R.

# Model SD

## Locking Type

The **SD** is a vertical lifting clamp that incorporates two Model S clamps into one and is used for heavy duty work where it is desirable to spread the gripping surfaces with two points of contact. It incorporates a "Lock Open," "Lock Closed" feature which facilitates attaching and removing the clamp from the plate.



### MODEL SD EXPLODED VIEW

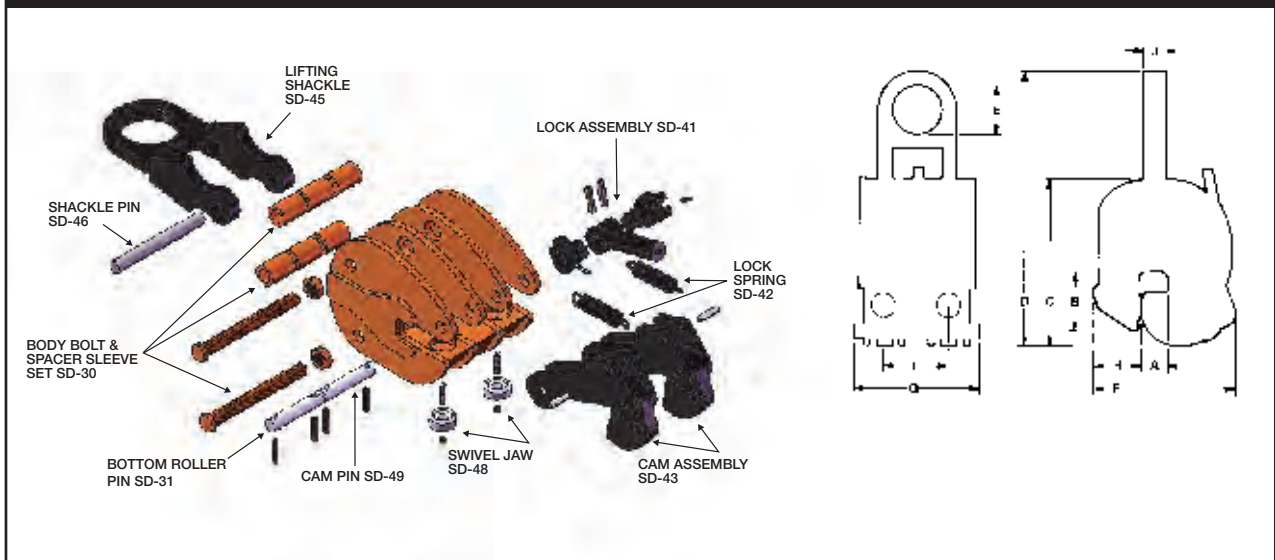

**SPECIFICATIONS** (in inches)

Rated Capacity Tons	Plate Thickness		MAX.								Weight (in pounds)
	A	B	C	D	E	F	G	H	I	J	
6	0-1	3/4	9 1/2	15 1/2	3	7 1/2	6 1/2	2 1/8	4 1/8	3/4	60
	3/4-1 1/2	3/4	9 1/2	15 1/2	3	8	6 1/2	2 1/8	4 1/8	3/4	62
8	0-1 1/4	4 1/2	11 1/2	17	3	8 3/4	6 3/4	3	4 1/4	1	77
	1-2	4 1/2	11 1/2	17	3	9 1/2	6 3/4	3	4 1/4	1	81

SPECIFICATIONS ARE SUBJECT TO CHANGE WITHOUT NOTICE. OTHER CAPACITIES AVAILABLE UPON REQUEST.

# VERTICAL + 90







# Model J

## Locking Type

The **Model J** is a vertical lifting clamp capable of turning a single plate or member from horizontal to vertical and back to horizontal through the same 90 degree arc.

### MODEL J EXPLODED VIEW

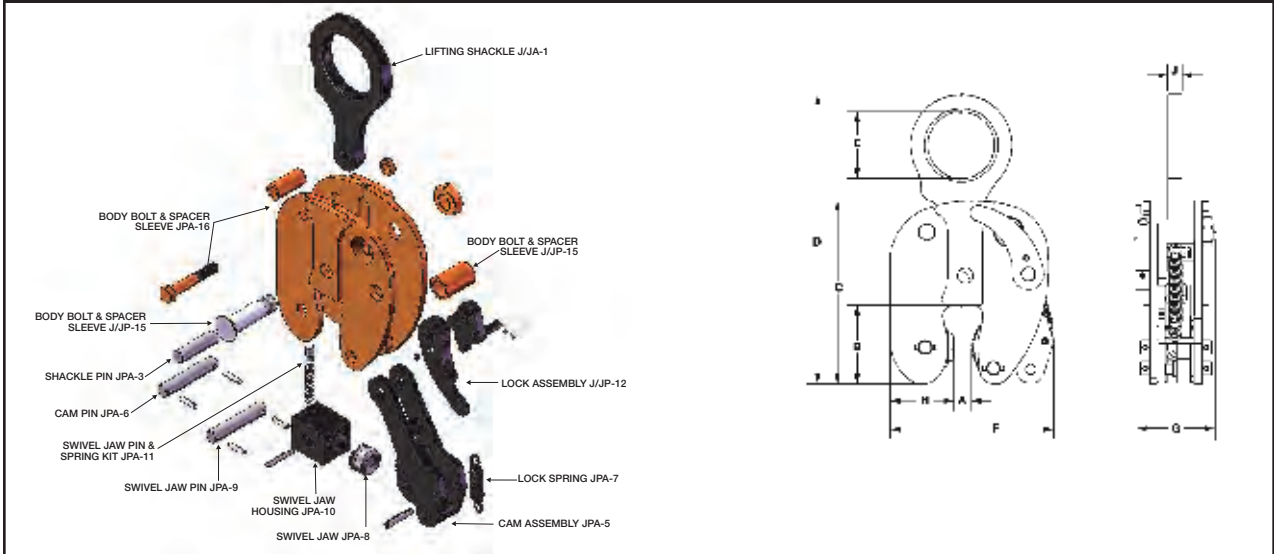

#### SPECIFICATIONS (in inches)

Rated Capacity Tons	Plate Thickness		MAX.								Weight (in pounds)
	A	B	C	D	E	F	G	H	J		
1/2	0-5/8	2 3/4	6 1/2	12	2 3/8	5 5/8	3 1/4	2 1/4	1/2	10	
	1/2-1	2 3/4	6 1/2	12	2 3/8	6	3 1/4	2 1/4	1/2		
	3/4-1 1/4	2 3/4	6 1/2	12	2 3/8	6 1/4	3 1/4	2 1/4	1/2		
	1 1/4-1 3/4	2 3/4	6 1/2	12	2 3/8	6 3/4	3 1/4	2 1/4	1/2		
1	0-3/4	3 3/8	7 3/4	13 3/4	2 5/8	7	3 1/2	2 5/8	5/8	15	
	1/2-1	3 3/8	7 3/4	13 3/4	2 5/8	7 1/4	3 1/2	2 5/8	5/8		
	3/4-1 1/4	3 3/8	7 3/4	13 3/4	2 5/8	8	3 1/2	2 5/8	5/8		
	1-1 1/2	3 3/8	7 3/4	13 3/4	2 5/8	8 1/4	3 1/2	2 5/8	5/8		
	1 1/2-2	3 3/8	7 3/4	13 3/4	2 5/8	8 3/4	3 1/2	2 5/8	5/8		
2	0-1	3 3/8	9 1/2	17 3/8	3 1/2	8 3/4	4 1/2	3	3/4	36	
	3/4-1 1/2	3 3/8	9 1/2	17 3/8	3 1/2	9 1/4	4 1/2	3	3/4		
	1 1/4-2	3 3/8	9 1/2	17 3/8	3 1/2	9 3/4	4 1/2	3	3/4		
	2-2 3/4	3 3/8	9 1/2	17 3/8	3 1/2	10 1/2	4 1/2	3	3/4		
4	3/16-1 1/4	4 3/8	11 1/2	20 7/8	3 1/2	9 1/4	4 1/2	3 1/4	1 1/2	42	
	1-2	4 3/8	11 1/2	20 7/8	3 1/2	10	4 1/2	3 1/4	1 1/2		
	2-3	4 3/8	11 1/2	20 7/8	3 1/2	11	4 1/2	3 1/4	1 1/2		
	3-4	4 3/8	11 1/2	20 7/8	3 1/2	12	4 1/2	3 1/4	1 1/2		
6	1/4-1 3/8	4 7/8	12 3/8	20 7/8	3 1/2	10 3/4	4 3/4	3 3/4	1 1/2	64	
	1-2 1/8	4 7/8	12 3/8	20 7/8	3 1/2	11 1/2	4 3/4	3 3/4	1 1/2		
	2-3 1/8	4 7/8	12 3/8	20 7/8	3 1/2	12 1/2	4 3/4	3 3/4	1 1/2		
	3-4 1/8	4 7/8	12 3/8	20 7/8	3 1/2	13 1/2	4 3/4	3 3/4	1 1/2		
8	3/8-1 1/2	5 3/8	12 3/4	22 5/8	3 3/4	12 3/8	5 1/4	4 1/4	2	83	
	1-2 1/8	5 3/8	12 3/4	22 5/8	3 3/4	13	5 1/4	4 1/4	2		
	2-3 1/8	5 3/8	12 3/4	22 5/8	3 3/4	14 3/8	5 1/4	4 1/4	2		
	3-4 1/8	5 3/8	12 3/4	22 5/8	3 3/4	15 3/8	5 1/4	4 1/4	2		
12	1/2-2 1/2	7 1/4	17 3/8	28 1/8	3 7/8	15 15/16	7 1/8	5 3/8	2	203	
	2-4	7 1/4	17 3/8	28 1/8	3 7/8	17 1/8	7 1/8	5 3/8	2	212	
	4-6	7 1/4	17 3/8	28 1/8	3 7/8	19 1/8	7 1/8	5 3/8	2	222	
16	1/2-2 1/2	8	19 13/16	32 5/16	4 1/2	19 13/16	8 11/16	6 1/4	2 1/4	350	
	2-3	8 5/8	21 13/16	35 1/8	5	21	11 1/2	6 7/8	2 3/4	456	
25	1/2-2 1/2	8 5/8	23 5/8	35 7/8	5	19 1/16	9 5/8	6 3/4	3	483	
	3-5	8 5/8	23 5/8	35 7/8	5	21 9/16	9 5/8	6 3/4	3	495	
	4-6	8 5/8	23 5/8	35 7/8	5	22 9/16	9 5/8	6 3/4	3	502	
30	1/2-3	9 5/16	24 1/4	39 7/8	5	22 13/16	14 9/16	7 5/8	3	625	
50	3-5	10 7/8	30 7/8	46 7/16	5	29 3/16	11 1/8	9 1/4	3 1/2	1306	

Consult factory for possible larger capacities. SPECIFICATIONS ARE SUBJECT TO CHANGE WITHOUT NOTICE



## Model L

The **Model L** is an ergonomic vertical lifting clamp capable of turning a single plate or member from horizontal to vertical to horizontal through a 90 degree arc. The “Lock Open – Lock Closed” feature facilitates attaching and removing the clamp from the plate.

### MODEL L EXPLODED VIEW

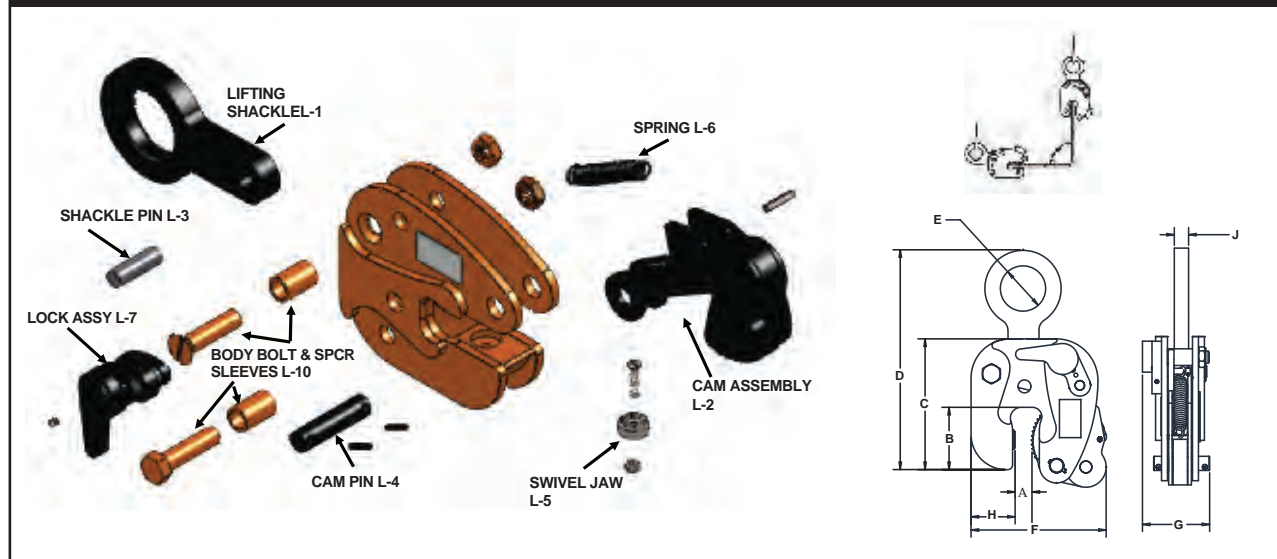

#### SPECIFICATIONS (in inches)

Rated Capacity Tons	Plate Thickness A	B	C	MAX. D	E	MAX. F	G	H	J	Weight (in pounds)
1/2	0-5/8	2	4 7/8	8	1 1/8	4 1/4	2 7/16	1 3/8	3/8	4 1/8
1	0-3/4	2	4 7/8	8	1 1/8	4 3/8	2 7/16	1 3/8	1/2	5 1/8
2	0-1	3 5/16	6 7/8	12 1/2	2 3/8	7 1/16	3 5/8	2 3/8	3/4	16 7/8
3	0-1	3 7/16	10	17	3 3/8	8 1/2	3 13/16	2 3/4	3/4	32

Consult factory for possible larger capacities. SPECIFICATIONS ARE SUBJECT TO CHANGE WITHOUT NOTICE

# Model LJ

## Locking Type

The **MODEL LJ** is a vertical lifting clamp capable of turning a plate from horizontal to vertical and back through the same ninety-degree arc. It is small and easy to handle in capacities through three tons. The Model LJ incorporates a “Lock Closed” feature, which facilitates attaching the clamp to the plate.



### MODEL LJ EXPLODED VIEW

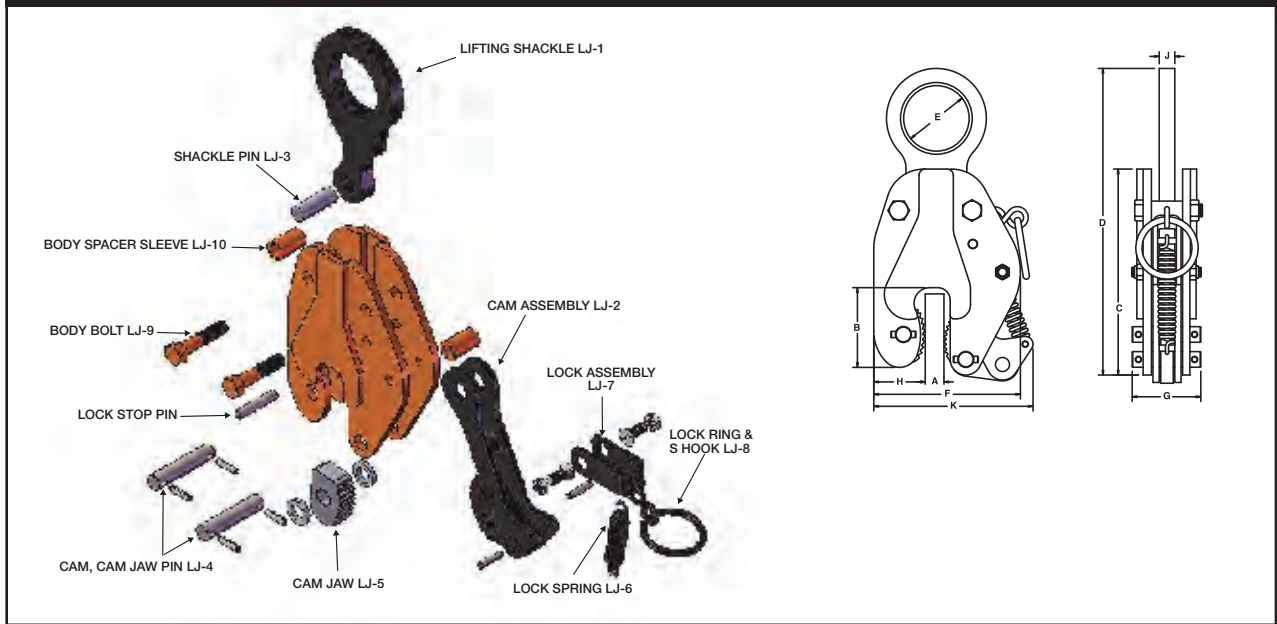

**SPECIFICATIONS** (in inches)

Rated Capacity Tons	Plate Thickness A	B	C	MAX. D	E	F	G	H	J	K	Weight (in pounds)
1/2	0-3/4	2 5/8	6 5/8	10 1/4	2 1/4	5	2 3/8	1 7/8	1/2	5	9
1	0-3/4	3 3/16	8 1/4	13 7/16	2 5/8	5 7/8	2 7/8	2 1/16	5/8	6 7/16	15
2	0-1	3 5/8	9	15 13/16	3 5/8	7 1/4	3 1/4	2 7/8	3/4	7 5/8	26
3	0-1 1/4	4 1/4	10 3/4	18	3 5/8	8 3/16	3 5/8	3	3/4	8 3/8	34

SPECIFICATIONS ARE SUBJECT TO CHANGE WITHOUT NOTICE.



# Model TL

## Locking Type

The **Model TL** is a vertical lifting clamp capable of turning a single plate or member from horizontal to vertical and back to horizontal through the same 90 degree arc.

### MODEL TL EXPLODED VIEW

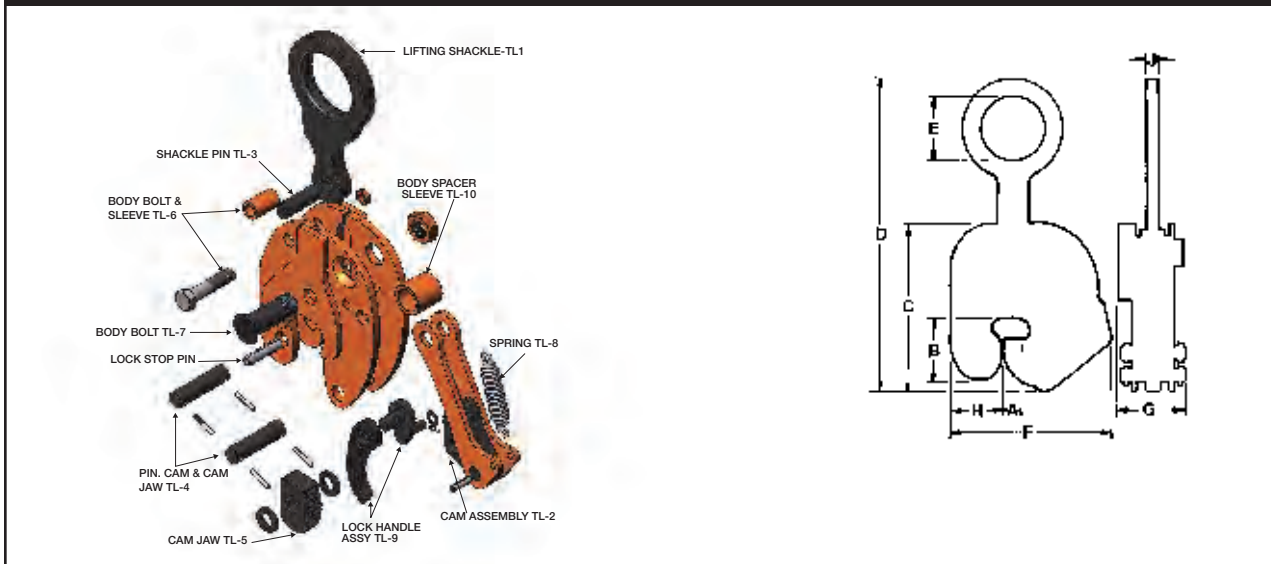

**SPECIFICATIONS** (in inches)

Rated Capacity Tons	Plate Thickness A	B	C	MAX. D	E	MAX. F	G	H	J	Weight (in pounds)
1/2	0-5/8	2 3/8	6 1/4	11 1/2	2 3/8	4 3/8	2 3/8	1 13/16	1/2	9
	1/2-1	2 3/8	6 1/4	11 1/2	2 3/8	5 1/8	2 3/8	1 13/16	1/2	10
	3/4-1 1/4	2 3/8	6 1/4	11 1/2	2 3/8	5 3/8	2 3/8	1 13/16	1/2	11
	1 1/4-1 3/4	2 3/8	6 1/4	11 1/2	2 3/8	5 5/8	2 3/8	1 13/16	1/2	13
1	0-3/4	3	7 1/2	13 3/8	2 5/8	6	2 13/16	2	5/8	14
	1/2-1	3	7 1/2	13 3/8	2 5/8	6 1/4	2 13/16	2	5/8	15
	3/4-1 1/4	3	7 1/2	13 3/8	2 5/8	6 1/2	2 13/16	2	5/8	16
	1-1 1/2	3	7 1/2	13 3/8	2 5/8	6 3/4	2 13/16	2	5/8	17
	1 1/2-2	3	7 1/2	13 3/8	2 5/8	7 1/4	2 13/16	2	5/8	18
2	0-1	3 1/2	9 3/8	16 1/4	3 3/8	8 3/8	3 3/4	2 7/8	3/4	32
	3/4-1 1/2	3 1/2	9 3/8	16 1/4	3 3/8	9 3/8	3 3/4	2 7/8	3/4	33
	1 1/4-2	3 1/2	9 3/8	16 1/4	3 3/8	9 3/4	3 3/4	2 7/8	3/4	35
	2-2 3/4	3 1/2	9 3/8	16 1/4	3 3/8	10 3/8	3 3/4	2 7/8	3/4	37
4	3/8-1 1/4	4	9 3/8	17 5/8	3 3/8	9	3 13/16	3	3/4	36
	1-2	4	9 3/8	17 5/8	3 3/8	9 3/4	3 13/16	3	3/4	37
	2-3	4	9 3/8	17 5/8	3 3/8	10 3/4	3 13/16	3	3/4	40
	3-4	4	9 3/8	17 5/8	3 3/8	11 3/4	3 13/16	3	3/4	43
6	1/4-1 3/8	4 3/8	11 1/8	20 3/8	3 1/2	10 3/4	3 3/8	3 3/8	3/4	49
	1-2 1/8	4 3/8	11 1/8	20 3/8	3 1/2	11	3 3/8	3 3/8	3/4	51
	2-3 1/8	4 3/8	11 1/8	20 3/8	3 1/2	12	3 3/8	3 3/8	3/4	54
	3-4 1/8	4 3/8	11 1/8	20 3/8	3 1/2	13	3 3/8	3 3/8	3/4	57
8	3/8-1 1/2	4 13/16	12 3/16	21 5/16	3 3/4	11 1/2	4 3/4	3 3/8	1	72
	1-2 1/8	4 13/16	12 3/16	21 5/16	3 3/4	12 1/8	4 3/4	3 3/8	1	74
	2-3 1/8	4 13/16	12 3/16	21 5/16	3 3/4	13 1/8	4 3/4	3 3/8	1	77
	3-4 1/8	4 13/16	12 3/16	21 5/16	3 3/4	14 1/8	4 3/4	3 3/8	1	80
12	1/2-2 1/2	6 1/4	15 1/8	26 3/16	3 3/8	14 1/2	6 3/4	4 3/8	1 3/4	142
	2-4	6 1/4	15 1/8	26 3/16	3 3/8	16	6 3/4	4 3/8	1 3/4	150
	3-5	6 1/4	15 1/8	26 3/16	3 3/8	17	6 3/4	4 3/8	1 3/4	154
	4-6	6 1/4	15 1/8	26 3/16	3 3/8	18	6 3/4	4 3/8	1 3/4	158
20	1/2-3	8 3/8	21 3/4	36 11/16	5	20 11/16	8 1/8	6 3/16	2 3/4	415
	2 1/2-4 1/2	8 3/8	21 3/4	36 11/16	5	22 3/16	8 1/8	6 3/16	2 3/4	426
	3-5	8 3/8	21 3/4	36 11/16	5	22 11/16	8 1/8	6 3/16	2 3/4	430
	5-7	8 3/8	21 3/4	36 11/16	5	24 11/16	8 1/8	6 3/16	2 3/4	445

Consult factory for possible larger capacities. SPECIFICATIONS ARE SUBJECT TO CHANGE WITHOUT NOTICE





# VERTICAL + 90 + SIDE PULL







# Model JP Locking Type

The **Model JP** is a vertical lifting clamp capable of turning a single plate or member from horizontal to vertical and back to horizontal through the same 90 degree arc. Permits side loading of lifting shackle up to 90 degrees by derating of clamp's rated capacity. Refer to FIGURE 1 for derated capacities.

**Model JP** incorporates a pivoting shackle that permits side loading of the lifting shackle at 100 percent of rated capacity from vertical to 30 degrees, 75 percent of rated capacity between 30 and 45 degrees and 50 percent of rated capacity between 45 and 90 degrees

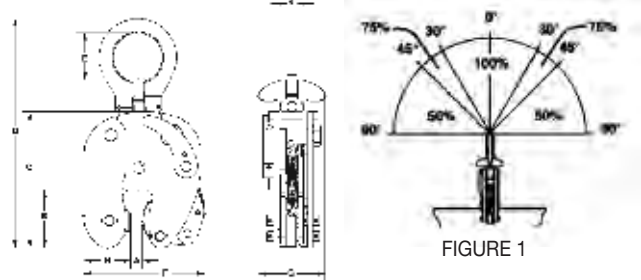
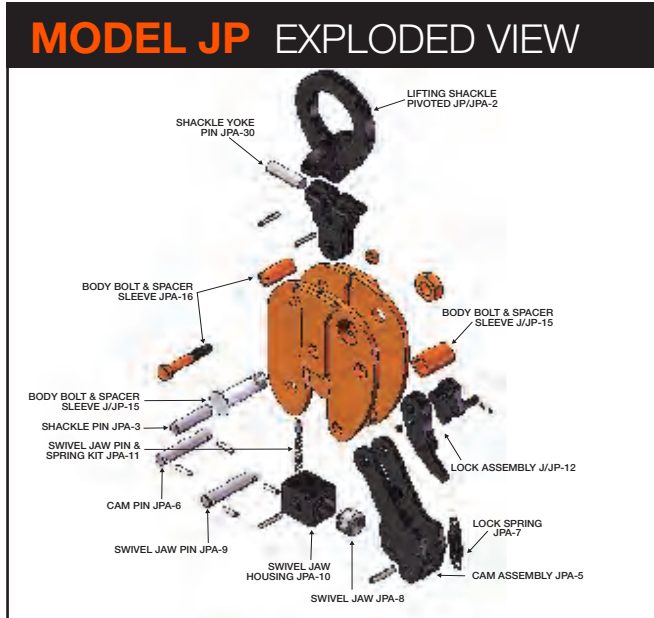

**SPECIFICATIONS** (in inches)

Rated Capacity Tons	Plate Thickness A	B	C	MAX. D	E	MAX. F	G	H	J	Weight (in pounds)
1/2	0-5/8	2 3/4	6 1/2	12	2 3/8	5 3/8	3 3/4	2 1/4	1/2	12
	1/2-1	2 3/4	6 1/2	12	2 3/8	6	3 3/4	2 1/4	1/2	
	3/4-1 1/4	2 3/4	6 1/2	12	2 3/8	6 1/4	3 3/4	2 1/4	1/2	
	1 1/4-1 3/4	2 3/4	6 1/2	12	2 3/8	6 3/4	3 3/4	2 1/4	1/2	
1	0-3/4	3 3/8	7 3/4	13 3/4	2 5/8	7	3 1/2	2 5/8	5/8	20
	1/2-1	3 3/8	7 3/4	13 3/4	2 5/8	7 1/4	3 1/2	2 5/8	5/8	
	3/4-1 1/4	3 3/8	7 3/4	13 3/4	2 5/8	8	3 1/2	2 5/8	5/8	
	1-1 1/2	3 3/8	7 3/4	13 3/4	2 5/8	8 1/4	3 1/2	2 5/8	5/8	
2	0-1	3 3/8	9 1/2	17 3/4	3 1/2	8 3/4	4 1/2	3	3/4	40
	3/4-1 1/2	3 3/8	9 1/2	17 3/4	3 1/2	9 1/4	4 1/2	3	3/4	
	1 1/4-2	3 3/8	9 1/2	17 3/4	3 1/2	9 3/4	4 1/2	3	3/4	
	2-2 3/4	3 3/8	9 1/2	17 3/4	3 1/2	10 1/2	4 1/2	3	3/4	
4	3/8-1 1/4	4 3/8	11 1/2	20 1/2	3 1/2	9 3/4	4 1/2	3 3/4	1 1/2	50
	1-2	4 3/8	11 1/2	20 1/2	3 1/2	10	4 1/2	3 3/4	1 1/2	
	2-3	4 3/8	11 1/2	20 1/2	3 1/2	11	4 1/2	3 3/4	1 1/2	
	3-4	4 3/8	11 1/2	20 1/2	3 1/2	12	4 1/2	3 3/4	1 1/2	
6	1/2-1 1/8	4 7/8	12 3/4	20 3/4	3 1/2	10 3/4	4 3/4	3 3/4	1 3/4	72
	1-2 1/8	4 7/8	12 3/4	20 3/4	3 1/2	11 1/2	4 3/4	3 3/4	1 3/4	
	2-3 1/8	4 7/8	12 3/4	20 3/4	3 1/2	12 1/2	4 3/4	3 3/4	1 3/4	
	3-4 1/8	4 7/8	12 3/4	20 3/4	3 1/2	13 1/2	4 3/4	3 3/4	1 3/4	
8	3/4-1 1/2	5 3/8	12 3/4	22 3/4	3 3/4	12 3/4	5 1/4	4 1/4	2	93
	1-2 1/8	5 3/8	12 3/4	22 3/4	3 3/4	13	5 1/4	4 1/4	2	
	2-3 1/8	5 3/8	12 3/4	22 3/4	3 3/4	14 3/8	5 1/4	4 1/4	2	
	3-4 1/8	5 3/8	12 3/4	22 3/4	3 3/4	15 3/8	5 1/4	4 1/4	2	
12	1/2-2 1/2	7 1/4	17 3/8	28 1/8	3 7/8	15 1/16	7 1/16	5 3/8	2	203
	2-4	7 1/4	17 3/8	28 1/8	3 7/8	17 1/16	7 1/16	5 3/8	2	212
	4-6	7 1/4	17 3/8	28 1/8	3 7/8	19 1/16	7 1/16	5 3/8	2	222
16	1/2-2 1/2	8	19 13/16	32 5/16	4 1/2	19 13/16	8 11/16	6 1/4	2 1/4	350
20	1/2-3	8 5/8	21 13/16	35 7/8	5	21	11 1/2	6 7/8	2 3/4	456
25	1/2-2 1/2	8 5/8	23 5/8	35 7/8	5	19 1/16	9 5/8	6 3/4	3	483
	3-5	8 5/8	23 5/8	35 7/8	5	21 1/16	9 5/8	6 3/4	3	495
	4-6	8 5/8	23 5/8	35 7/8	5	22 9/16	9 5/8	6 3/4	3	502
30	1/2-3	9 9/16	24 1/4	39 7/8	5	22 13/16	14 9/16	7 5/8	3	625
50	3-5	10 7/8	30 7/8	46 7/8	5	29 3/16	11 1/8	9 1/4	3 1/2	1306

Consult factory for possible larger capacities. SPECIFICATIONS ARE SUBJECT TO CHANGE WITHOUT NOTICE

VERTICAL + 90 + SIDE PULL

# Model LP



The **Model LP** is an ergonomic vertical lifting clamp capable of turning a single plate or member from horizontal to vertical to horizontal through a 90 degree arc. Permits side loading of lifting shackle to 90 degrees by de-rating of clamp's capacity. Refer to FIGURE 1 for de-rated capacities. The "Lock Open – Lock Closed" feature facilitates attaching and removing the clamp from the plate.

**Model LP** incorporates a pivoting shackle that permits side loading of the lifting shackle at 100 percent of rated capacity from vertical to 30 degrees, 75 percent of rated capacity between 30 and 45 degrees, and 50 percent of rated capacity between 45 and 90 degrees.

## MODEL LP EXPLODED VIEW

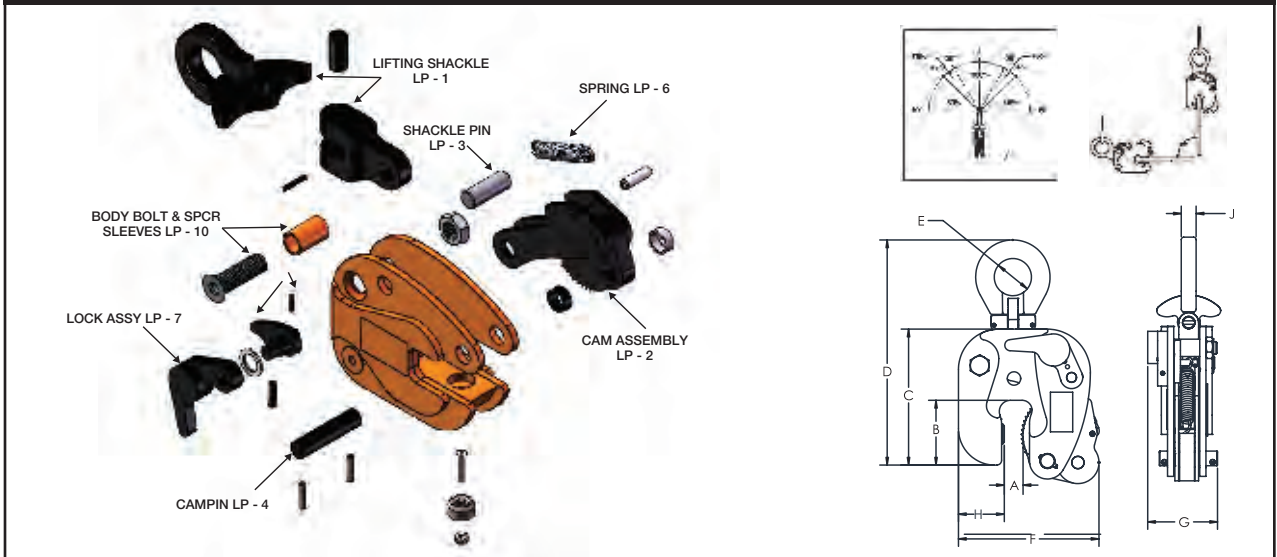

### SPECIFICATIONS (in inches)

Rated Capacity Tons	Plate Thickness A	B	C	MAX. D	E	MAX. F	G	H	J	Weight (in pounds)
1/2	0-5/8	2	5 1/16	8 11/16	1 1/8	4 1/4	2 7/16	1 3/8	3/8	4 1/8
1	0-3/4	2	5 1/8	8 11/16	1 1/8	4 3/8	2 7/16	1 3/8	1/2	5 1/8
2	0-1	3 5/16	6 7/8	12 1/2	1 7/8	7 1/16	3 5/8	2 3/8	3/4	16 7/8
3	0-1	3 7/16	10	17	3 3/8	8 1/2	3 13/16	2 3/4	3/4	32

Consult factory for possible larger capacities. SPECIFICATIONS ARE SUBJECT TO CHANGE WITHOUT NOTICE

# VERTICAL + 180





# Model DC

## Locking Type

**Model DC** is vertical lifting, locking and 180° turning clamp. The DC's unique design, utilizing two movable gripping cams, allows this clamp to lift any load within its plate size range from 0 up to 6 ton with a 300 Brinell hardness or less.



### MODEL DC EXPLODED VIEW

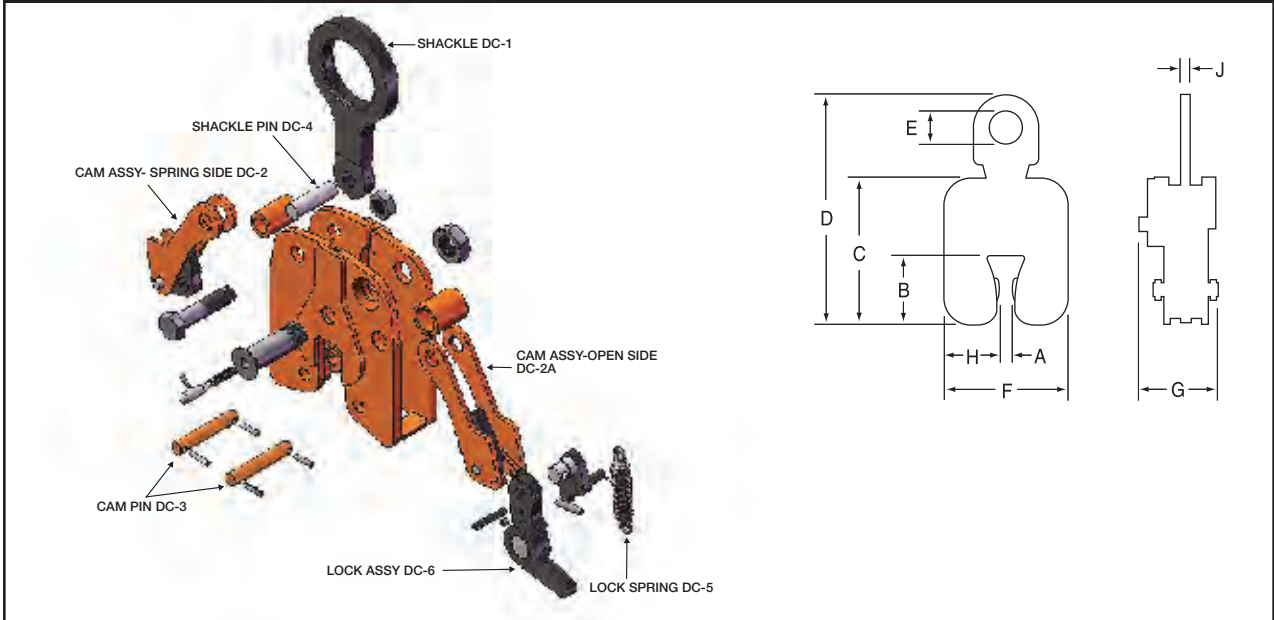

**SPECIFICATIONS** (in inches)

Model	Rated Capacity Tons	Plate Thickness A	B	MAX. C	D	E	F	G	H	J	Weight (in pounds)
DC-A	1/2	0 - 5/8	2 5/16	5	7 7/8	1 1/8	4 3/8	2 5/8	1 7/8	5/16	6
DC-B	1/2	0 - 3/4	2 9/16	6 5/16	9 1/4	1 1/8	5 1/2	2 3/4	2 3/8	5/16	9
DC-C	1/2	3/4 - 1 1/2	2 9/16	6 3/8	9 1/2	1 1/8	6 1/4	2 3/4	2 3/8	5/16	10
DC	1	0 - 1 1/8	3 3/8	7 5/16	12 1/8	2 5/8	6 3/8	3 3/4	2 5/8	5/16	15
DC	3	0 - 3/4	4 3/4	9 1/4	17 1/4	3 5/8	8	4 3/8	3 5/8	3/4	30
DC	6	0 - 1	5 7/8	11 1/2	19	3 1/2	10 1/2	4 3/4	4 3/4	1 1/2	54
DC	6	1 1/2 - 3	5 7/8	11 5/8	19	3 1/2	10 7/8	4 3/4	4	1 1/2	51
DC	6	2 - 3	5 7/8	11 5/8	19	3 1/2	10 7/8	4 3/4	4	1 1/2	51

SPECIFICATIONS ARE SUBJECT TO CHANGE WITHOUT NOTICE.



# Model JA

## Locking Type

The **Model JA** is a vertical lifting clamp capable of turning a single plate or member from horizontal to vertical to horizontal through a 180 degree arc. It incorporates a push button auxiliary lock.

### MODEL JA EXPLODED VIEW

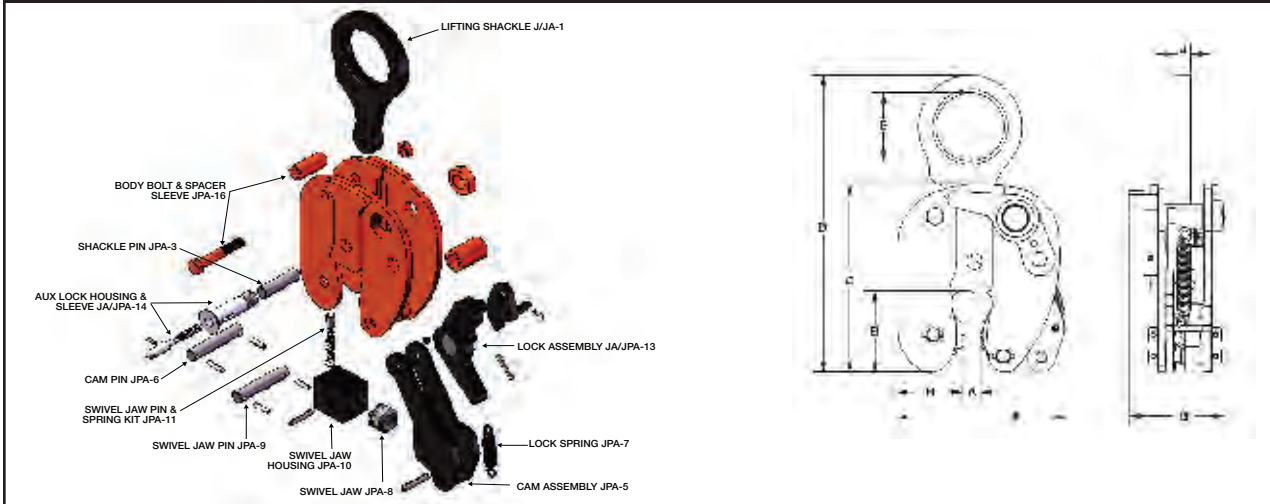

#### SPECIFICATIONS (in inches)

Rated Capacity Tons	Plate Thickness A	B	C	MAX. D	E	MAX. F	G	H	J	Weight (in pounds)
1/2	0-5/8	2 3/4	6 1/2	12	2 5/8	5 5/8	3 1/4	2 1/4	1 1/2	10
	1/2-1	2 3/4	6 1/2	12	2 5/8	6	3 1/4	2 1/4	1 1/2	
	3/4-1 1/4	2 3/4	6 1/2	12	2 5/8	6 1/4	3 1/4	2 1/4	1 1/2	
	1 1/4-1 3/4	2 3/4	6 1/2	12	2 5/8	6 3/4	3 1/4	2 1/4	1 1/2	
1	0-3/4	3 3/8	7 3/4	13 3/4	2 5/8	7	3 1/2	2 5/8	5/8	15
	1/2-1	3 3/8	7 3/4	13 3/4	2 5/8	7 1/4	3 1/2	2 5/8	5/8	
	3/4-1 1/4	3 3/8	7 3/4	13 3/4	2 5/8	8	3 1/2	2 5/8	5/8	
	1-1 1/2	3 3/8	7 3/4	13 3/4	2 5/8	8 1/2	3 1/2	2 5/8	5/8	
2	1 1/2-2	3 3/8	7 3/4	13 3/4	2 5/8	8 3/4	3 1/2	2 5/8	5/8	36
	0-1	3 3/8	9 1/2	17 3/8	3 1/2	8 3/4	4 1/2	3	3/4	
	3/4-1 1/2	3 3/8	9 1/2	17 3/8	3 1/2	9 1/4	4 1/2	3	3/4	
	1 1/4-2	3 3/8	9 1/2	17 3/8	3 1/2	9 3/4	4 1/2	3	3/4	
4	2-2 3/4	3 3/8	9 1/2	17 3/8	3 1/2	10 1/2	4 1/2	3	3/4	42
	3/8-1 1/4	4 3/8	11 1/2	20 1/2	3 1/2	9 1/4	4 1/2	3 3/4	1 1/2	
	1-2	4 3/8	11 1/2	20 1/2	3 1/2	10	4 1/2	3 3/4	1 1/2	
	2-3	4 3/8	11 1/2	20 1/2	3 1/2	11	4 1/2	3 3/4	1 1/2	
6	3-4	4 3/8	11 1/2	20 1/2	3 1/2	12	4 1/2	3 3/4	1 1/2	64
	1/4-1 3/8	4 3/8	12 3/8	20 7/8	3 1/2	10 3/4	4 3/4	3 3/4	1 1/2	
	1-2 1/8	4 3/8	12 3/8	20 7/8	3 1/2	11 1/2	4 3/4	3 3/4	1 1/2	
	2-3 3/8	4 3/8	12 3/8	20 7/8	3 1/2	12 1/2	4 3/4	3 3/4	1 1/2	
8	3-4 3/8	4 3/8	12 3/8	20 7/8	3 1/2	13 1/2	4 3/4	3 3/4	1 1/2	83
	3/8-1 1/2	5 3/8	12 3/4	22 3/8	3 3/4	12 3/8	5 1/4	4 1/4	2	
	1-2 1/8	5 3/8	12 3/4	22 3/8	3 3/4	13	5 1/4	4 1/4	2	
	2-3 3/8	5 3/8	12 3/4	22 3/8	3 3/4	14 5/8	5 1/4	4 1/4	2	
12	3-4 1/8	5 3/8	12 3/4	22 3/8	3 3/4	15 1/8	5 1/4	4 1/4	2	203
	1 1/2-2 1/2	7 1/4	17 3/8	28 1/8	3 7/8	15 15/16	7 1/16	5 5/8	2	
	2-4	7 1/4	17 3/8	28 1/8	3 7/8	17 1/16	7 1/16	5 5/8	2	
16	4-6	7 1/4	17 3/8	28 1/8	3 7/8	19 7/16	7 1/16	5 5/8	2	212
	1 1/2-2 1/2	8	19 13/16	32 5/16	4 1/2	19 13/16	8 11/16	6 1/4	2 1/4	
20	1/2-3	8 5/8	21 13/16	35 7/8	5	21	11 1/2	6 3/8	2 3/4	350
25	1/2-2 1/2	8 3/8	23 3/8	35 3/8	5	19 1/16	9 5/8	6 3/4	3	483
	3-5	8 3/8	23 3/8	35 3/8	5	21 9/16	9 5/8	6 3/4	3	495
	4-6	8 3/8	23 3/8	35 3/8	5	22 9/16	9 5/8	6 3/4	3	502
30	1/2-3	9 9/16	24 1/4	39 7/8	5	22 13/16	14 3/16	7 5/8	3	625
50	3-5	10 7/8	30 7/8	46 7/16	5	29 3/16	11 1/8	9 1/4	3 1/2	1306

Consult factory for possible larger capacities. SPECIFICATIONS ARE SUBJECT TO CHANGE WITHOUT NOTICE



# Model LA

**Model LA** is an ergonomic vertical lifting clamp capable of turning a single plate or member from horizontal to vertical to horizontal through a 180 degree arc. It incorporates a push button auxiliary lock. The “Lock Open – Lock Closed” feature facilitates attaching and removing the clamp from the plate.



## MODEL LA EXPLODED VIEW

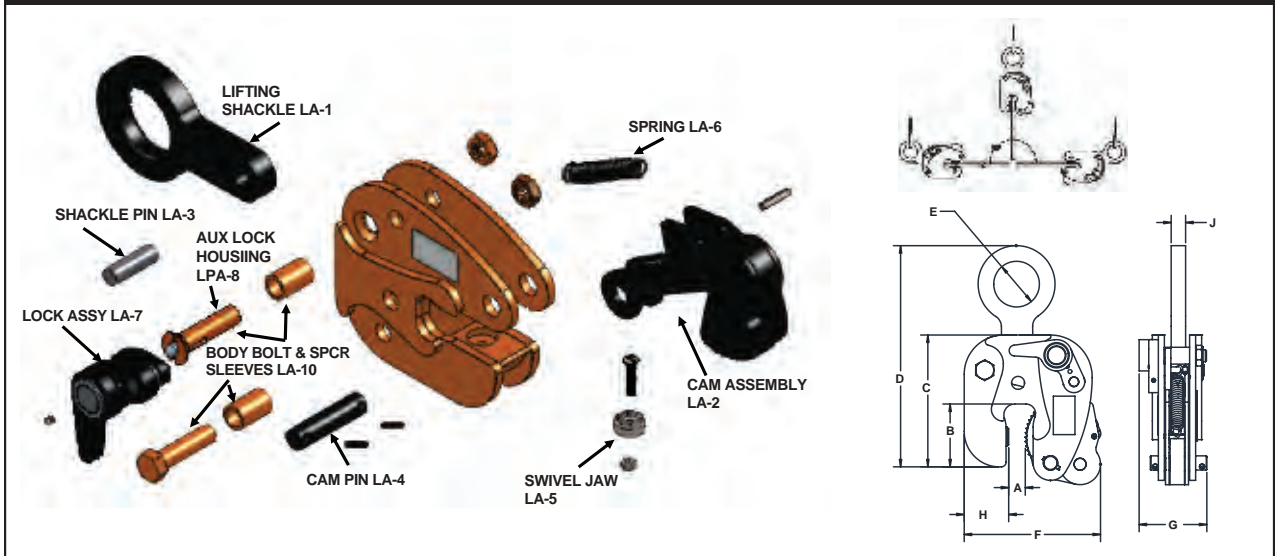

**SPECIFICATIONS** (in inches)

Rated Capacity Tons	Plate Thickness A	B	C	MAX. D	E	MAX. F	G	H	J	Weight (in pounds)
1/2	0-5/8	2	4 7/8	8	1 1/8	4 1/4	2 7/16	1 3/8	3/8	4 1/8
1	0-3/4	2	4 7/8	8	1 1/8	4 3/8	2 7/16	1 3/8	1/2	5 1/8
2	0-1	3 5/16	6 7/8	12 1/2	2 3/8	7 1/16	3 5/8	2 3/8	3/4	16 7/8
3	0-1	3 7/16	10	17	3 3/8	8 1/2	3 13/16	2 3/4	3/4	32

Consult factory for possible larger capacities. SPECIFICATIONS ARE SUBJECT TO CHANGE WITHOUT NOTICE



# Model PCK-SL

## Locking, Screw Type



The PCK Locking Screw Clamp is a versatile multipurpose lifting turning pulling clamp capable of lift and turn operations from the horizontal through 180 degrees arc. The clamp can also be used for the assembling of steel plates, structural members and welded sections. The clamp is generally used in pairs for the purpose of drawing two plates or members together or to a predetermined position adjacent to each other. The adjusting screw is used to accommodate various thicknesses of material and to facilitate the attachment of the clamp to the member being worked on.

### MODEL PCK EXPLODED VIEW

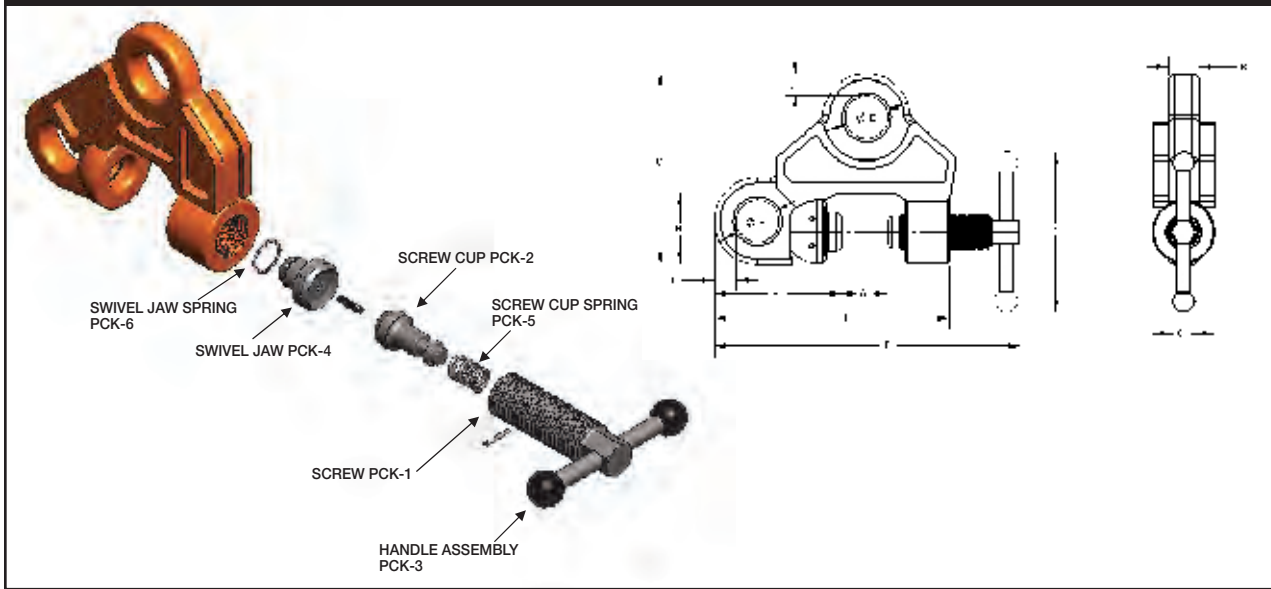

**SPECIFICATIONS** (in inches)

Capacity Tons	Plate Thickness A	B	C	D	E	F	G	H	Weight			(in kg)
									J	K	L	
0.5	0-1	2½	5½	5 <sup>11</sup> / <sub>16</sub>	1	9½	1¾	3	1/2	5 <sup>5</sup> / <sub>16</sub>	6½	4.64
1	0-1½	3	6¾	5 <sup>11</sup> / <sub>16</sub>	1¾	10½	2½	4 <sup>1</sup> / <sub>2</sub>	1 <sup>11</sup> / <sub>16</sub>	¾	7 <sup>5</sup> / <sub>8</sub>	9.6
2	0-1½	3 <sup>3</sup> / <sub>16</sub>	7½	7	1½	11½	2 <sup>3</sup> / <sub>8</sub>	4 <sup>9</sup> / <sub>16</sub>	¾	1	8½	14.5
3	¾-1¾	3½	8	6 <sup>11</sup> / <sub>16</sub>	1¾	12½	2 <sup>5</sup> / <sub>8</sub>	5 <sup>3</sup> / <sub>8</sub>	7 <sup>7</sup> / <sub>8</sub>	1½	9½	17.94
5	0-1½	3 <sup>13</sup> / <sub>16</sub>	9 <sup>5</sup> / <sub>16</sub>	7 <sup>3</sup> / <sub>8</sub>	2	13 <sup>3</sup> / <sub>8</sub>	2 <sup>7</sup> / <sub>8</sub>	5 <sup>7</sup> / <sub>8</sub>	1	1 <sup>3</sup> / <sub>8</sub>	10	28.42

SPECIFICATIONS ARE SUBJECT TO CHANGE WITHOUT NOTICE.

# Model RSC

## Locking Type

The **Model RSC** is a lightweight screw clamp for bench work on steel plates of large thickness, and weighing less than 1000 lbs.



### MODEL RSC EXPLODED VIEW

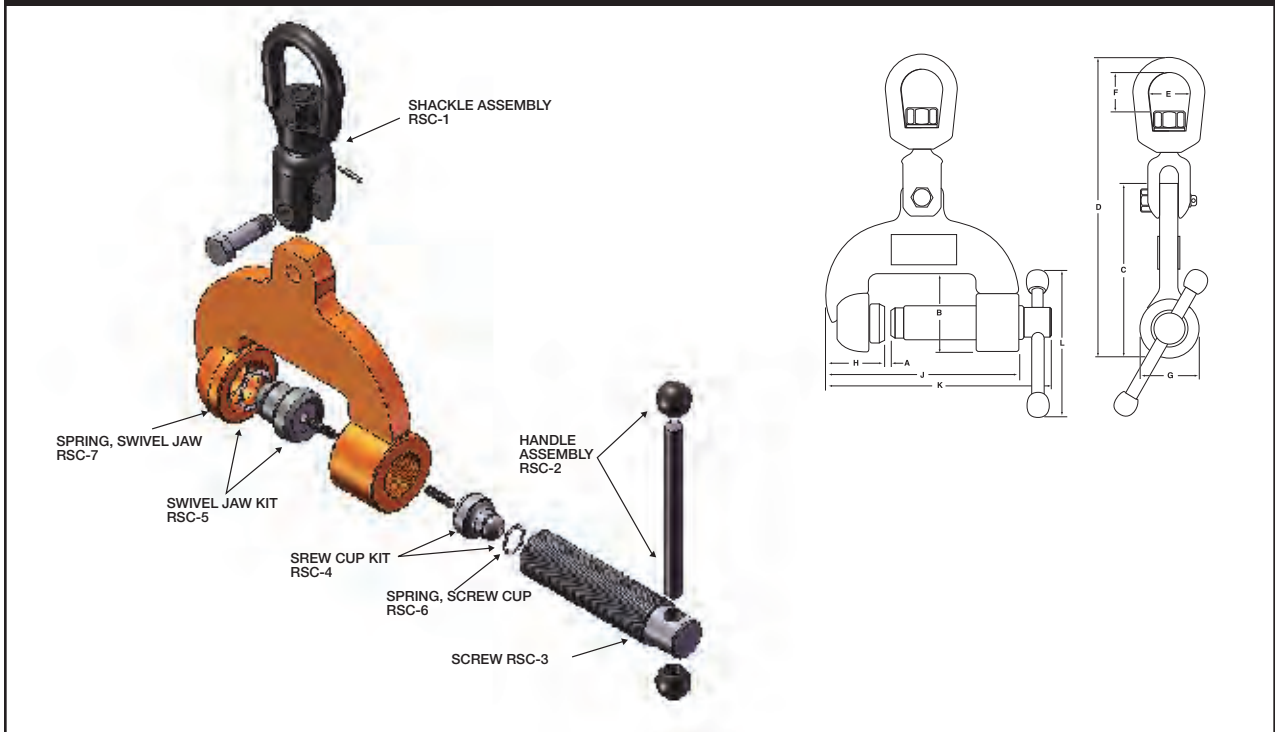

**SPECIFICATIONS** (in inches)

Rated Capacity Tons	Plate Thickness A	B	C	D	E	F	G	H	Weight			
									J	K	L (in pounds)	
1/2	0-3	3 <sup>3</sup> / <sub>16</sub>	7	12 <sup>3</sup> / <sub>16</sub>	1 <sup>1</sup> / <sub>4</sub>	1 <sup>1</sup> / <sub>16</sub>	2 <sup>3</sup> / <sub>8</sub>	2 <sup>3</sup> / <sub>8</sub>	7 <sup>7</sup> / <sub>8</sub>	11 <sup>7</sup> / <sub>8</sub>	6 <sup>3</sup> / <sub>4</sub>	13 <sup>1</sup> / <sub>2</sub>
1/2	1 <sup>1</sup> / <sub>8</sub> -4 <sup>1</sup> / <sub>4</sub>	3 <sup>3</sup> / <sub>16</sub>	7 <sup>5</sup> / <sub>16</sub>	12 <sup>5</sup> / <sub>16</sub>	1 <sup>1</sup> / <sub>4</sub>	1 <sup>1</sup> / <sub>16</sub>	2 <sup>3</sup> / <sub>8</sub>	2 <sup>3</sup> / <sub>8</sub>	9 <sup>1</sup> / <sub>4</sub>	13 <sup>1</sup> / <sub>8</sub>	6 <sup>3</sup> / <sub>4</sub>	16 <sup>1</sup> / <sub>2</sub>

SPECIFICATIONS ARE SUBJECT TO CHANGE WITHOUT NOTICE.



# Model SCP

## Locking, Screw Type

The **Model SCP** clamp is capable of handling steel plate from horizontal to vertical to horizontal through a 180 degree arc and may be used for handling plate at rolling and forming machines. These clamps feature a spring loaded pivoting cam jaw that "cams in" when a load is applied to the lifting shackle. Clamp is capable of handling plate horizontally when used in pairs or sets of pairs, or in a tripod arrangement.

### MODEL SCP EXPLODED VIEW

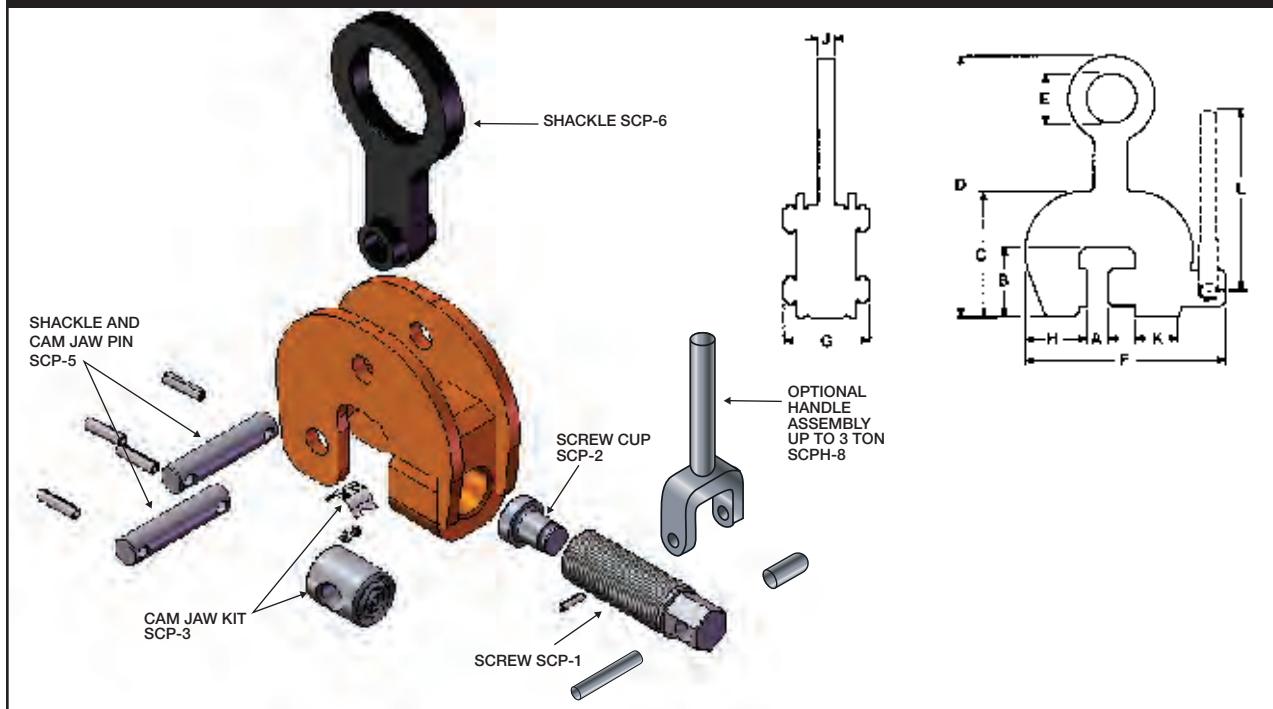

**SPECIFICATIONS** (in inches)

Rated Capacity Tons	Plate Thickness		Dimensions											Weight			
	A	B	C	D	E	F	G	H	J	K	L	M	N	P	(in pounds)		
1/2	0-3/4	2 3/8	4 1/2	9	2 3/8	6 5/8	2 3/8	1 7/8	1/2	1 1/2	—	1 3/4	1 3/4	9/16	7		
1 1/2	0-1 1/4	2 7/8	5 1/2	10 9/16	2 5/8	8 7/16	3 3/8	2 3/8	5/8	1 3/4	8 1/4	2	2	1 1/16	13		
3	0-2	3 1/8	5 3/4	12	2 3/8	10 13/16	4 1/16	2 13/16	3/4	2	8 5/8	3	6	3/4	19		
6	0-2 1/2	4 5/16	7 9/16	14 3/8	3	14 3/8	5 3/8	3 7/16	1	2 15/16	—	3 1/2	7	1	44		
10	0-3	5 1/2	9 3/4	19 1/4	3 1/4	16 3/8	6 3/4	4 3/8	1	3 1/8	—	3 1/2	7	1	93		
15	0-4	7 1/4	12 1/8	22 7/8	3 3/4	21 1/2	8 1/4	5 9/16	1 1/4	4	—	3 7/8	8	1 1/4	210		

20, 30, 50, 100 and 150 Ton capacities available upon request. SPECIFICATIONS ARE SUBJECT TO CHANGE WITHOUT NOTICE.

# Model SCSL

## Locking, Screw Type



The **MODEL SCSL** is a locking screw clamp capable of handling a steel plate from horizontal to vertical to horizontal through a 180-degree arc. It is a lightweight clamp primarily used for bench work. It is capable of handling up to a 2,000-pound load. The **MODEL SCSL** incorporates a spring loaded swivel jaw and screw cup. The spring loaded screw cup serves as an indicator when the locking screw has been properly tightened.

### MODEL SCSL EXPLODED VIEW

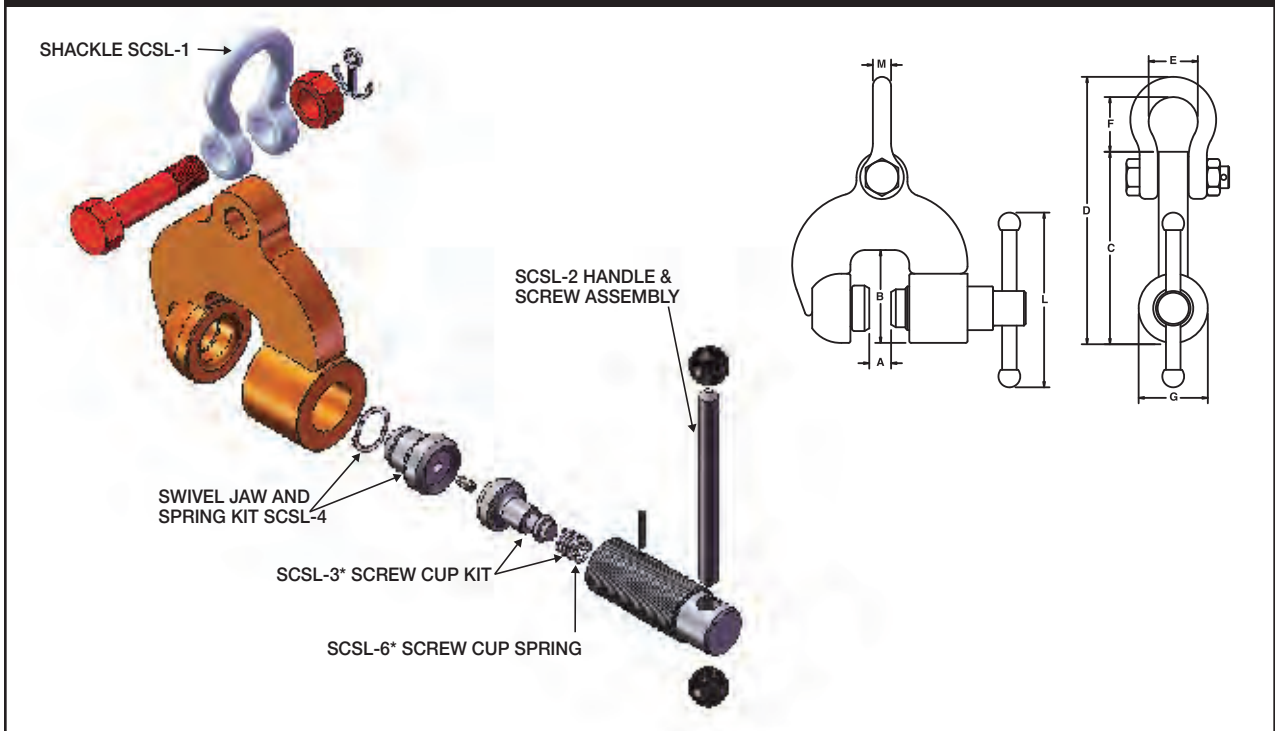

**SPECIFICATIONS** (in inches)

Rated Capacity Tons	Plate Thickness A	B	C	D	E	F	G	Weight L	M	(in pounds)
1	0-3/4	3 1/4	6 5/8	9 3/16	1 11/16	1 7/8	2 1/2	6	5/8	12

SPECIFICATIONS ARE SUBJECT TO CHANGE WITHOUT NOTICE.





# Model SCSM

## Locking, Screw Type

The **MODEL SCSM** is a locking screw clamp capable of handling a steel plate from horizontal to vertical to horizontal through a 180-degree arc. It is a lightweight clamp primarily used for bench work. It is capable of handling up to a 2,000-pound load.

### MODEL SCSM EXPLODED VIEW

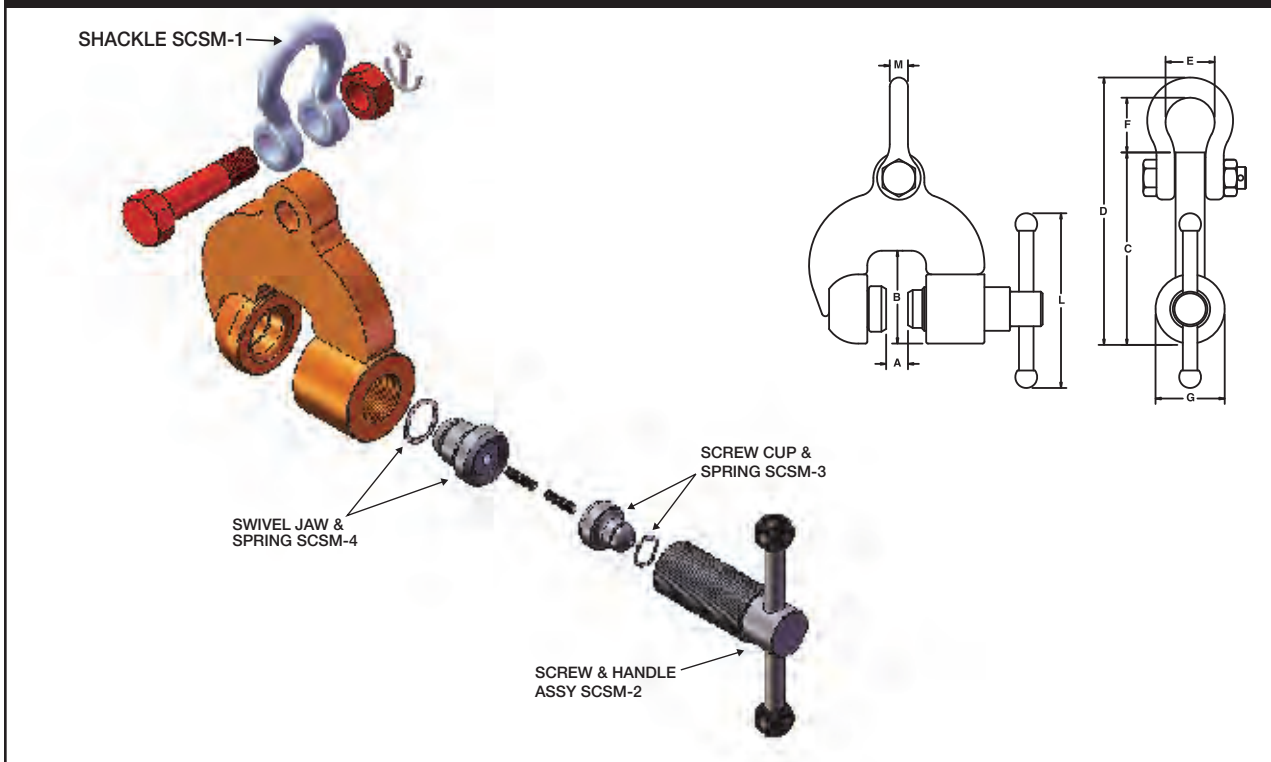

VERTICAL + 180

**SPECIFICATIONS** (in inches)

Rated Capacity Tons	Plate Thickness A	B	C	D	E	F	G	Weight L	M	(in pounds)
1	0- <sup>3</sup> / <sub>4</sub>	3 <sup>1</sup> / <sub>4</sub>	6 <sup>5</sup> / <sub>16</sub>	9 <sup>9</sup> / <sub>16</sub>	1 <sup>11</sup> / <sub>16</sub>	1 <sup>7</sup> / <sub>8</sub>	2 <sup>1</sup> / <sub>2</sub>	6	5 <sup>5</sup> / <sub>8</sub>	12

SPECIFICATIONS ARE SUBJECT TO CHANGE WITHOUT NOTICE.



# Model TLA

## Locking Type

The **Model TLA** is a vertical lifting clamp incorporating a “Lock Open” and a “Lock Closed” feature and an auxiliary push button lock. The clamp is capable of turning a steel plate from horizontal to vertical to horizontal through a 180 degree arc. The “Lock Open,” “Lock Closed” feature facilitates attaching and removing the clamp from the plate.

### MODEL TLA EXPLODED VIEW



#### SPECIFICATIONS (in inches)

Rated Capacity Tons	Plate Thickness A	B	C	MAX. D	E	MAX. F	G	H	J	Weight (in pounds)
1/2	0-3/8	2 3/8	6 1/4	11 1/8	2 3/8	4 3/8	2 3/8	1 13/16	1/2	9
	3/8-1	2 3/8	6 1/4	11 1/8	2 3/8	5 3/8	2 3/8	1 13/16	1/2	10
	1-1 1/4	2 3/8	6 1/4	11 1/8	2 3/8	5 3/8	2 3/8	1 13/16	1/2	11
	1 1/4-1 3/4	2 3/8	6 1/4	11 1/8	2 3/8	5 3/8	2 3/8	1 13/16	1/2	13
1	0-3/4	3	7 1/2	13 1/8	2 5/8	6	2 13/16	2	5/8	14
	3/4-1	3	7 1/2	13 1/8	2 5/8	6 1/8	2 13/16	2	5/8	15
	1-1 1/4	3	7 1/2	13 1/8	2 5/8	6 1/2	2 13/16	2	5/8	16
	1-1 1/2	3	7 1/2	13 1/8	2 5/8	6 3/4	2 13/16	2	5/8	17
	1 1/2-2	3	7 1/2	13 1/8	2 5/8	7 1/4	2 13/16	2	5/8	18
2	0-1	3 1/2	9 3/8	16 1/4	3 3/8	8 3/8	3 3/4	2 7/8	3/4	32
	3/4-1 1/2	3 1/2	9 3/8	16 1/4	3 3/8	9 3/8	3 3/4	2 7/8	3/4	33
	1 1/4-2	3 1/2	9 3/8	16 1/4	3 3/8	9 3/8	3 3/4	2 7/8	3/4	35
	2-2 1/4	3 1/2	9 3/8	16 1/4	3 3/8	10 3/8	3 3/4	2 7/8	3/4	37
4	3/8-1 1/4	4	9 7/8	17 3/8	3 5/8	9	3 13/16	3	3/4	36
	1-2	4	9 7/8	17 3/8	3 5/8	9 3/4	3 13/16	3	3/4	37
	2-3	4	9 7/8	17 3/8	3 5/8	10 3/4	3 13/16	3	3/4	40
	3-4	4	9 7/8	17 3/8	3 5/8	11 3/4	3 13/16	3	3/4	43
6	1/4-1 3/8	4 3/4	11 1/8	20 7/8	3 1/2	10 1/4	3 3/8	3 3/8	3/4	49
	1-2 1/8	4 3/4	11 1/8	20 7/8	3 1/2	11	3 3/8	3 3/8	3/4	51
	2-3 1/8	4 3/4	11 1/8	20 7/8	3 1/2	12	3 3/8	3 3/8	3/4	54
	3-4 1/8	4 3/4	11 1/8	20 7/8	3 1/2	13	3 3/8	3 3/8	3/4	57
8	3/8-1 1/2	4 13/16	12 5/16	21 5/8	3 3/4	11 1/2	4 3/8	3 3/8	1	72
	1-2 1/8	4 13/16	12 5/16	21 5/8	3 3/4	12 1/8	4 3/8	3 3/8	1	74
	2-3 1/8	4 13/16	12 5/16	21 5/8	3 3/4	13 1/8	4 3/8	3 3/8	1	77
	3-4 1/8	4 13/16	12 5/16	21 5/8	3 3/4	14 1/8	4 3/8	3 3/8	1	80
12	1/2-2 1/2	6 1/4	15 1/8	26 3/16	3 7/8	14 1/2	6 3/4	4 3/8	1 3/4	142
	2-4	6 1/4	15 1/8	26 3/16	3 7/8	16	6 3/4	4 3/8	1 3/4	150
	3-5	6 1/4	15 1/8	26 3/16	3 7/8	17	6 3/4	4 3/8	1 3/4	154
	4-6	6 1/4	15 1/8	26 3/16	3 7/8	18	6 3/4	4 3/8	1 3/4	158
20	1/2-3	8 1/8	21 3/4	36 11/16	5	20 11/16	8 1/8	6 3/16	2 3/4	415
	2 1/2-4 1/2	8 1/8	21 3/4	36 11/16	5	22 3/16	8 1/8	6 3/16	2 3/4	426
	3-5	8 1/8	21 3/4	36 11/16	5	22 11/16	8 1/8	6 3/16	2 3/4	430
	5-7	8 1/8	21 3/4	36 11/16	5	24 11/16	8 1/8	6 3/16	2 3/4	445

Consult factory for possible larger capacities. SPECIFICATIONS ARE SUBJECT TO CHANGE WITHOUT NOTICE

# VERTICAL + 180 + SIDE PULL





# Model JPA

## Locking Type

The **Model JPA** is a vertical lifting clamp capable of turning a single plate or member from horizontal to vertical to horizontal through a 180 degree arc. Incorporates a push button auxiliary lock. Permits side loading of lifting shackle to 90 degrees by derating of clamp's rated capacity. Refer to FIGURE 1 for derated capacities.

**Model JPA** incorporates a pivoting shackle that permits side loading of the lifting shackle at 100 percent of rated capacity from vertical to 30 degrees, 75 percent of rated capacity between 30 and 45 degrees and 50 percent of rated capacity between 45 and 90 degrees.

### MODEL JPA EXPLODED VIEW

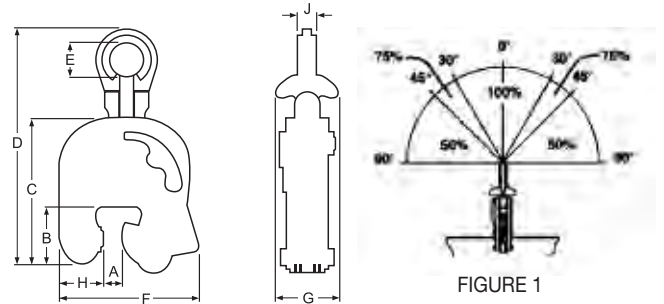
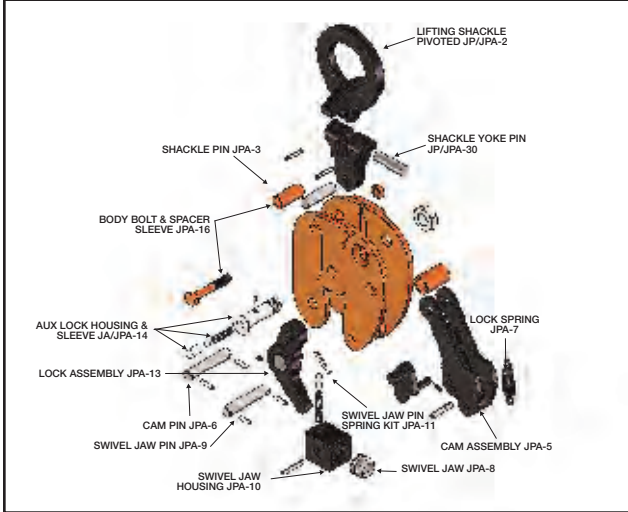

FIGURE 1

### SPECIFICATIONS (in inches)

Rated Capacity Tons	Plate Thickness A	B	C	MAX. D	E	MAX. F	G	H	J	Weight (in pounds)
1/2	0-5/8	2 3/4	6 1/2	12	2 3/8	5 5/8	3 1/4	2 1/4	1 1/2	12
	1/2-1	2 3/4	6 1/2	12	2 3/8	6	3 1/4	2 1/4	1 1/2	
	3/4-1 1/4	2 3/4	6 1/2	12	2 3/8	6 1/4	3 1/4	2 1/4	1 1/2	
	1 1/4-1 3/4	2 3/4	6 1/2	12	2 3/8	6 3/4	3 1/4	2 1/4	1 1/2	
1	0-3/4	3 3/8	7 3/4	13 3/4	2 5/8	7	3 1/2	2 5/8	5/8	20
	1/2-1	3 3/8	7 3/4	13 3/4	2 5/8	7 1/4	3 1/2	2 5/8	5/8	
	3/4-1 1/4	3 3/8	7 3/4	13 3/4	2 5/8	8	3 1/2	2 5/8	5/8	
	1-1 1/2	3 3/8	7 3/4	13 3/4	2 5/8	8 1/4	3 1/2	2 5/8	5/8	
2	0-1	3 5/8	9 1/2	17 3/8	3 1/2	8 3/4	4 1/2	3	3/4	40
	3/4-1 1/2	3 5/8	9 1/2	17 3/8	3 1/2	9 1/4	4 1/2	3	3/4	
	1 1/4-2	3 5/8	9 1/2	17 3/8	3 1/2	9 3/4	4 1/2	3	3/4	
	2-2 1/4	3 5/8	9 1/2	17 3/8	3 1/2	10 1/2	4 1/2	3	3/4	
4	3/8-1 1/4	4 3/8	11 1/2	20 1/8	3 1/2	9 1/4	4 1/2	3 1/4	1 1/2	50
	1-2	4 3/8	11 1/2	20 1/8	3 1/2	10	4 1/2	3 1/4	1 1/2	
	2-3	4 3/8	11 1/2	20 1/8	3 1/2	11	4 1/2	3 1/4	1 1/2	
	3-4	4 3/8	11 1/2	20 1/8	3 1/2	12	4 1/2	3 1/4	1 1/2	
6	1/4-1 3/8	4 7/8	12 3/8	20 7/8	3 1/2	10 3/4	4 3/4	3 3/4	1 3/4	72
	1-2 1/8	4 7/8	12 3/8	20 7/8	3 1/2	11 1/2	4 3/4	3 3/4	1 3/4	
	2-3 1/8	4 7/8	12 3/8	20 7/8	3 1/2	12 1/2	4 3/4	3 3/4	1 3/4	
	3-4 1/8	4 7/8	12 3/8	20 7/8	3 1/2	13 1/2	4 3/4	3 3/4	1 3/4	
8	3/8-1 1/2	5 3/8	12 3/4	22 3/8	3 3/4	12 3/8	5 1/4	4 1/4	2	93
	1-2 1/8	5 3/8	12 3/4	22 3/8	3 3/4	13	5 1/4	4 1/4	2	
	2-3 1/8	5 3/8	12 3/4	22 3/8	3 3/4	14 3/8	5 1/4	4 1/4	2	
	3-4 1/8	5 3/8	12 3/4	22 3/8	3 3/4	15 3/8	5 1/4	4 1/4	2	
12	1/2-2 1/2	7 1/4	17 3/4	28 1/8	3 7/8	15 15/16	7 1/8	5 3/8	2	203
	2-4	7 1/4	17 3/4	28 1/8	3 7/8	17 1/16	7 1/8	5 3/8	2	212
	4-6	7 1/4	17 3/4	28 1/8	3 7/8	19 1/16	7 1/8	5 3/8	2	222
16	1/2-2 1/2	8	19 13/16	32 5/8	4 1/2	19 13/16	8 11/16	6 1/4	2 1/4	350
20	1/2-3	8 5/8	21 13/16	35 7/8	5	21	11 1/2	6 7/8	2 3/4	456
25	1/2-2 1/2	8 5/8	23 5/8	35 7/8	5	19 1/16	9 5/8	6 3/4	3	483
	3-5	8 5/8	23 5/8	35 7/8	5	21 1/16	9 5/8	6 3/4	3	495
	4-6	8 5/8	23 5/8	35 7/8	5	22 3/16	9 5/8	6 3/4	3	502
30	1/2-3	9 9/16	24 1/4	39 7/8	5	22 13/16	14 9/16	7 5/8	3	625
50	3-5	10 7/8	30 7/8	46 7/8	5	29 3/8	11 1/8	9 1/4	3 1/2	1306

Consult factory for possible larger capacities. SPECIFICATIONS ARE SUBJECT TO CHANGE WITHOUT NOTICE





# Model LPA

**Model LPA** is an ergonomic vertical lifting clamp capable of turning a single plate or member from horizontal to vertical to horizontal through a 180 degree arc. It incorporates an auxiliary push button lock. Permits side loading of lifting shackle to 90 degrees by de-rating of clamp's capacity. Refer to FIGURE 1 for de-rated capacities. The "Lock Open – Lock Closed" feature facilitates attaching and removing the clamp from the plate.

The **Model LPA** incorporates a pivoting shackle that permits side loading of the lifting shackle at 100 percent of rated capacity from vertical to 30 degrees, 75 percent of rated capacity between 30 and 45 degrees, and 50 percent of rated capacity between 45 and 90 degrees.

## MODEL LPA EXPLODED VIEW

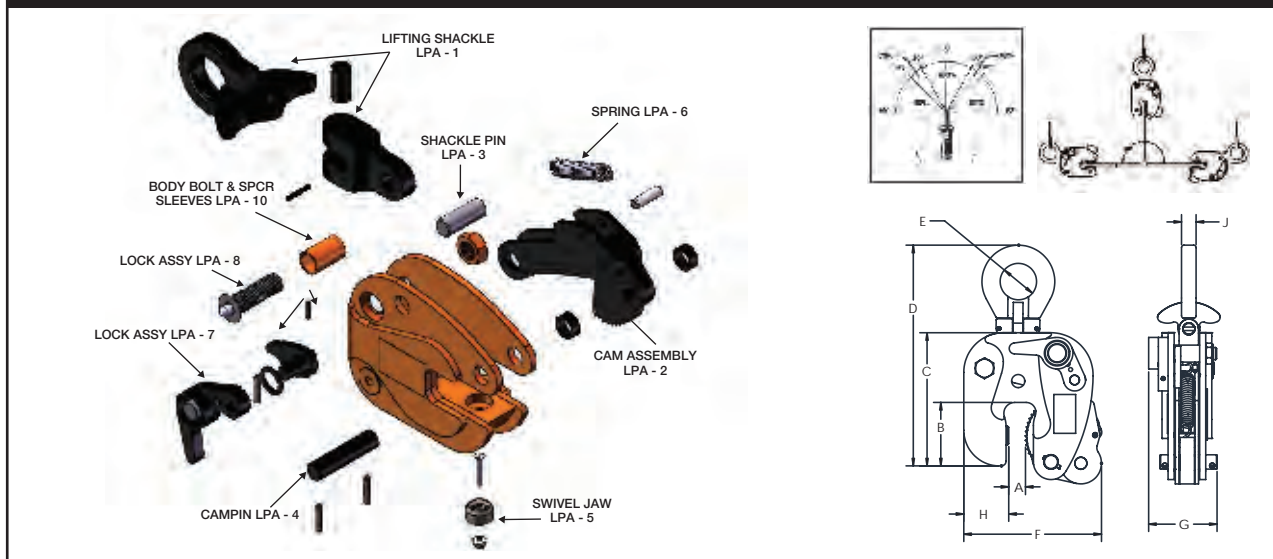

### SPECIFICATIONS (in inches)

Rated Capacity Tons	Plate Thickness A	B	C	MAX. D	E	MAX. F	G	H	J	Weight (in pounds)
1/2	0-5/8	2	5 1/16	8 11/16	1 1/8	4 1/4	2 7/16	1 3/8	3/8	4 1/8
1	0-3/4	2	5 1/8	8 11/16	1 1/8	4 3/8	2 7/16	1 3/8	1/2	5 1/8
2	0-1	3 5/16	6 7/8	12 1/2	1 7/8	7 1/16	3 5/8	2 3/8	3/4	16 7/8
3	0-1	3 7/16	10	17	3 5/8	8 1/2	3 13/16	2 3/4	3/4	32

Consult factory for possible larger capacities. SPECIFICATIONS ARE SUBJECT TO CHANGE WITHOUT NOTICE





# Model SCPA

## Locking, Screw Type



The **SCPA** clamp is capable of handling steel plate from horizontal to vertical to horizontal through a 180 degree arc and may be used for handling plate at rolling and forming machines. These clamps feature a spring loaded pivoting cam jaw that "cams in" when a load is applied to the lifting shackle. Clamp is capable of handling plate horizontally when used in pairs or sets of pairs, or in a tripod arrangement.

\*Pivoting shackle assembly, as shown, is available on capacities 3 tons and larger.

### MODEL SCPA EXPLODED VIEW

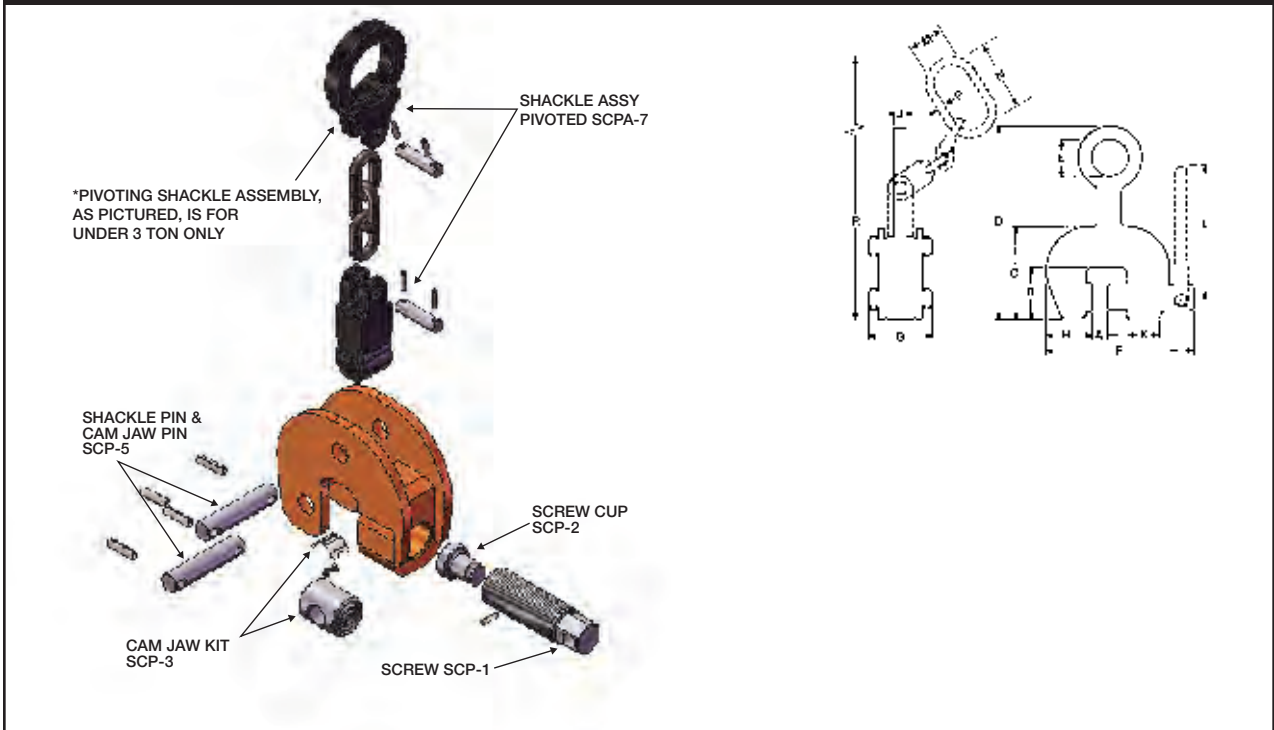

**SPECIFICATIONS** (in inches)

Rated Capacity Tons	Plate Thickness A	B	C	E	F	G	H	J	K	L	Weight				
											M	N	P	R (in pounds)	
1/2	0-3/4	2 3/8	4 1/2	2 3/8	6 5/8	2 3/8	1 7/8	1/2	1 1/2	—	1 3/4	1 3/4	9/16	12 3/16	8
1 1/2	0-1 1/4	2 7/8	5 1/2	2 5/8	8 7/16	3 3/8	2 3/8	5/8	1 3/4	8 1/4	2	2	1 1/16	14 3/16	15
3	0-2	3 1/8	5 3/4	2 3/8	10 13/16	4 1/8	2 13/16	3/4	2	8 5/8	3	6	3/4	21 3/8	24
6	0-2 1/2	4 5/16	7 9/16	3	14 3/8	5 3/8	3 7/16	1	2 15/16	—	3 1/2	7	1	27 3/4	57
10	0-3	5 1/2	9 3/4	3 1/4	16 3/8	6 3/4	4 3/8	1	3 1/8	—	3 1/2	7	1	29 7/16	134
15	0-4	7 1/4	12 1/8	3 3/4	21 1/2	8 1/4	5 9/16	1 1/4	4	—	3 7/8	8	1 1/4	36 1/2	312

20, 30, 50, 100 and 150 Ton capacities available upon request. SPECIFICATIONS ARE SUBJECT TO CHANGE WITHOUT NOTICE.

# The **Most** Versatile Tool In Your Shipyard Could Be A **Renfroe Clamp!**



The reliability and dependability of a Renfroe clamp has made the Renfroe line a preferred clamp by shipbuilders all over the world. J.C. Renfroe & Sons began in the Jacksonville, Florida shipyards over 70 years ago and has continuously supplied shipbuilders with specialty clamps designed specifically for shipyard needs. And with Renfroe's in-house engineering department, we can design and manufacture new clamp products to handle your yard's unique lifting applications.

## **FREE SAFETY TRAINING**

To increase the level of your employee's expertise in application, inspection and maintenance of clamps; or for the name of your nearest distributor, call **1-800-874-8454**.



SCAN CODE TO GO TO  
J.C. RENFROE CLAMPS

**RENFROE**

IT'LL TAKE A LOAD OFF YOUR MIND

Made in USA





# STRUCTURAL - SHAPES







## Model AST Non-Locking Type

Both the **Model AST** and **ASTL** were developed primarily for lifting, turning and stacking lightweight beams and structural shapes while a constant tension is applied to the lifting shackle. The horizontal shackle permits a beam to be lifted with the web in a near horizontal position by placing the clamp on the load with the shackle positioned over the web, and between the flanges. With a beam lying in a horizontal position, and the clamp placed with the shackle overhanging the flange, the beam can be lifted, turned 90 degrees, and raised in a vertical position.

### MODEL AST EXPLODED VIEW

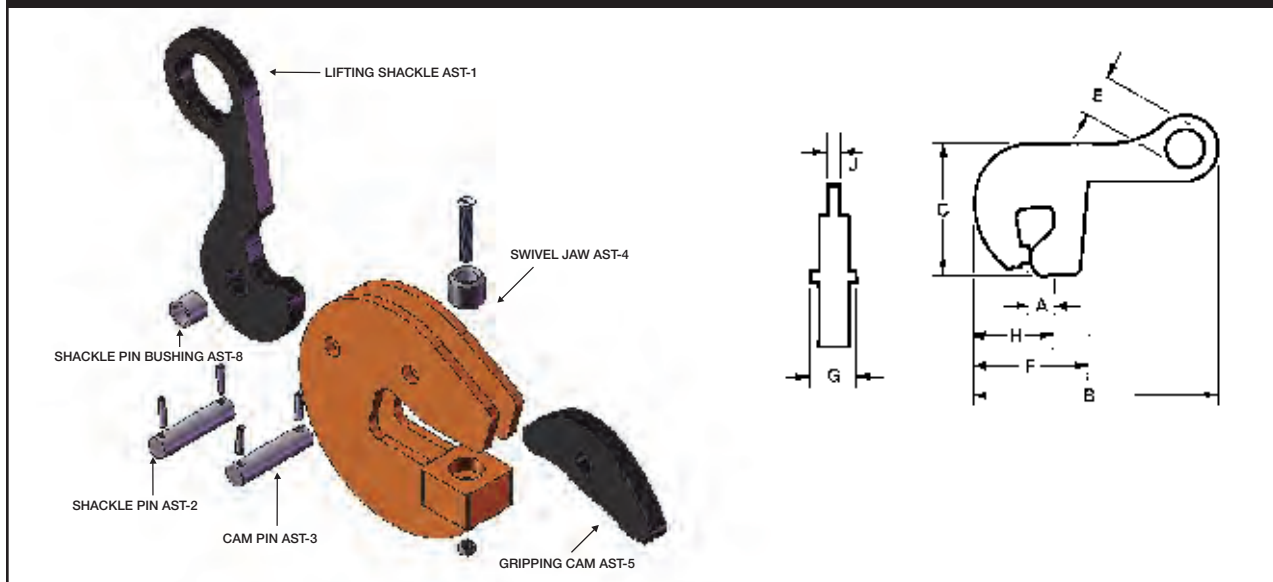

#### SPECIFICATIONS (in inches)

Rated Capacity Tons	Plate Thickness A	MAX. B	C	D	E	F	G	H	Weight J	(in pounds)
1/2	0-3/4	10 3/4	6 1/16	-	1 3/4	6 5/16	1 3/8	2 1/2	1/2	10
1 1/2	0-3/4	13	8 1/2	-	2 1/2	7	2 5/16	3	5/8	20
3	0-1 1/2	19 3/4	12 1/2	-	3 3/4	11	3	4 5/8	3/4	50

SPECIFICATIONS ARE SUBJECT TO CHANGE WITHOUT NOTICE.

# Model ASTL Non-Locking Type



Both the **Model AST** and **ASTL** were developed primarily for lifting, turning and stacking lightweight beams and structural shapes while a constant tension is applied to the lifting shackle. The horizontal shackle permits a beam to be lifted with the web in a near horizontal position by placing the clamp on the load with the shackle positioned over the web, and between the flanges. With a beam lying in a horizontal position, and the clamp placed with the shackle overhanging the flange, the beam can be lifted, turned 90 degrees, and raised in a vertical position.

The Model ASTL includes all of the feature of the Model AST plus a linkage which permits the tool to be removed remotely by setting the load down with the sling slack, then lifting the crane hook.

## MODEL ASTL EXPLODED VIEW

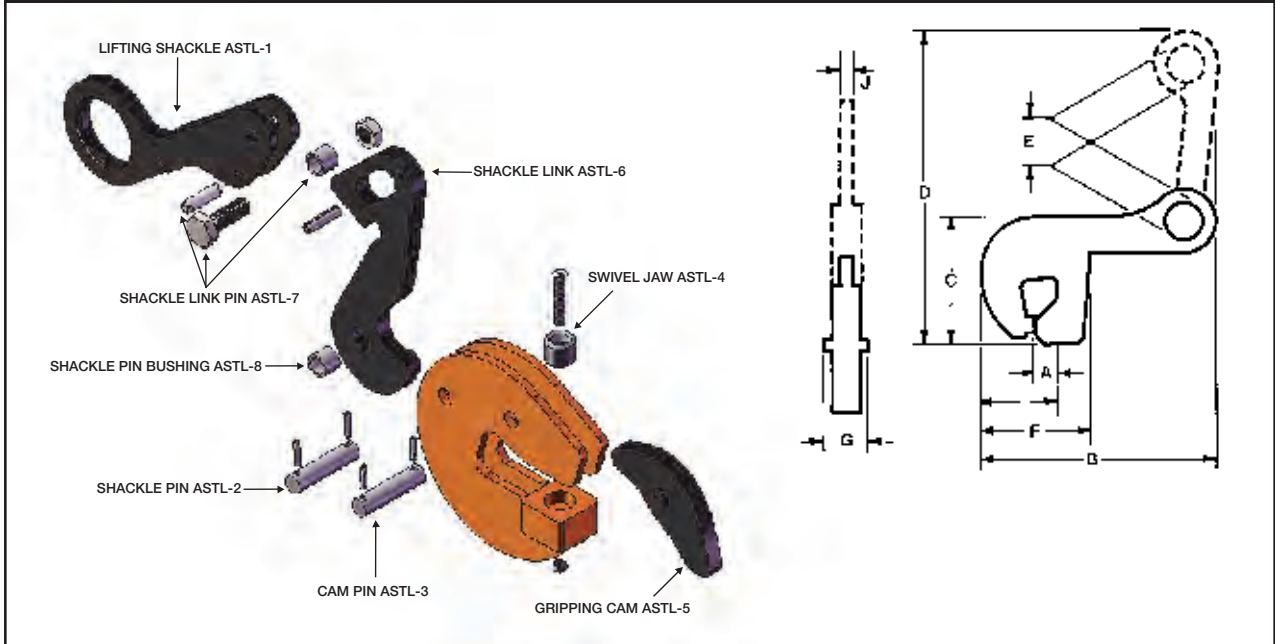

### SPECIFICATIONS (in inches)

Rated Capacity Tons	Plate Thickness A	MAX. B	C	D	E	F	G	H	Weight J	(in pounds)
<b>1/2</b>	0-3/4	10 3/4	6 1/16	14	1 3/4	6 3/16	1 3/8	2 1/2	1/2	10
<b>1 1/2</b>	0-3/4	13	8 1/2	18 1/2	2 1/2	7	2 5/16	3	3/4	24
<b>3</b>	0-1 1/2	19 3/4	12 1/2	25	3 3/4	11	3	4 3/4	3/4	61

SPECIFICATIONS ARE SUBJECT TO CHANGE WITHOUT NOTICE.



# Model AST-S Locking Type

The **Model ASTS** is the same as the Model AST with the exception that it incorporates a “Lock Closed” feature which facilitates attaching to the beam. Developed primarily for lifting, turning and stacking lightweight beams and structural shapes. The horizontal shackle permits a beam to be lifted with the web in a near horizontal position by placing the clamp on the load with the shackle positioned over the web, and between the flanges. With a beam lying in a horizontal position, and the clamp placed with the shackle over-hanging the flange, the beam can be lifted, turned 90 degrees, and raised in a vertical position.

## MODEL AST-S EXPLODED VIEW

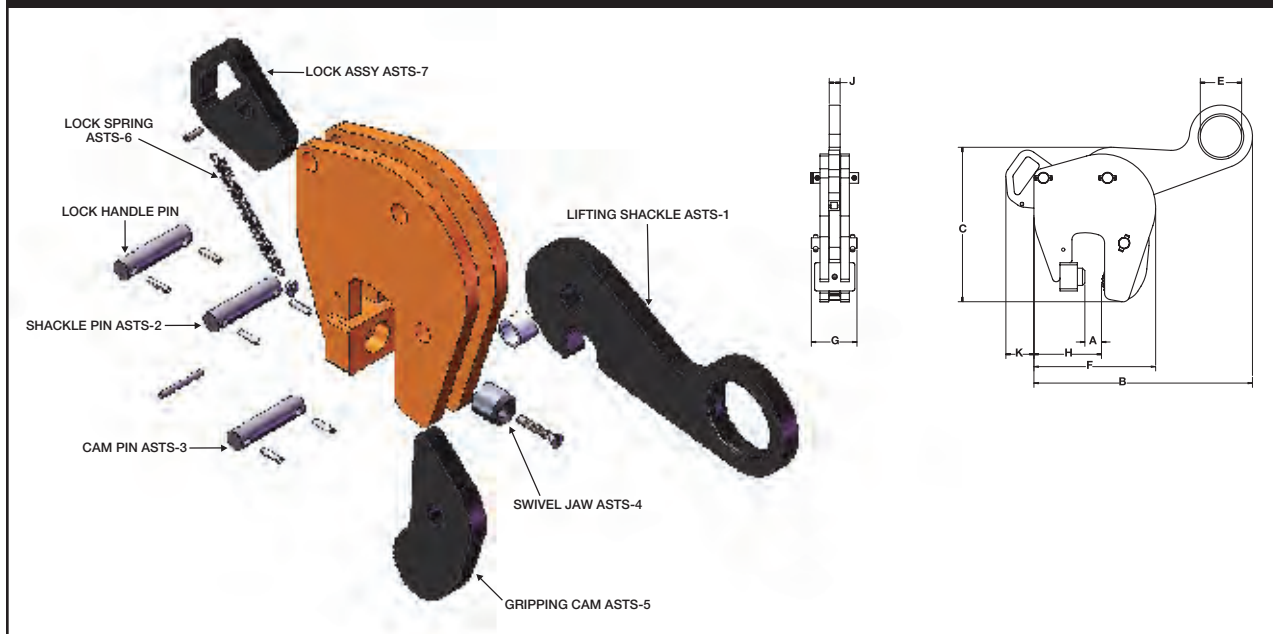

**SPECIFICATIONS** (in inches)

Rated Capacity Tons	Plate Thickness A	MAX. B	C	D	E	F	G	H	Weight J	K	(in pounds)
<b>1/2</b>	0-3/4	10 3/4	6 1/16	-	1 3/4	6 3/16	1 5/8	2 1/2	1/2	1 1/2	10
<b>1 1/2</b>	0-3/4	13	8 1/2	-	2 1/2	7	2 3/16	3	5/8	1 1/2	20
<b>3</b>	0-1 1/2	19 3/4	12 1/2	-	3 3/4	11	3	4 5/8	3/4	1 1/2	50

SPECIFICATIONS ARE SUBJECT TO CHANGE WITHOUT NOTICE.

# Model DG

## Locking Type



The **Model DG** rail clamp is used for lifting and transporting crane rails and railroad rails. Lightness of weight allows it to be hand applied and hand removed. The Model DG possesses all the features of the Model FR. All the repair parts are identical to same tonnage of the FR, except the swivel jaw has been eliminated.

### MODEL DG EXPLODED VIEW

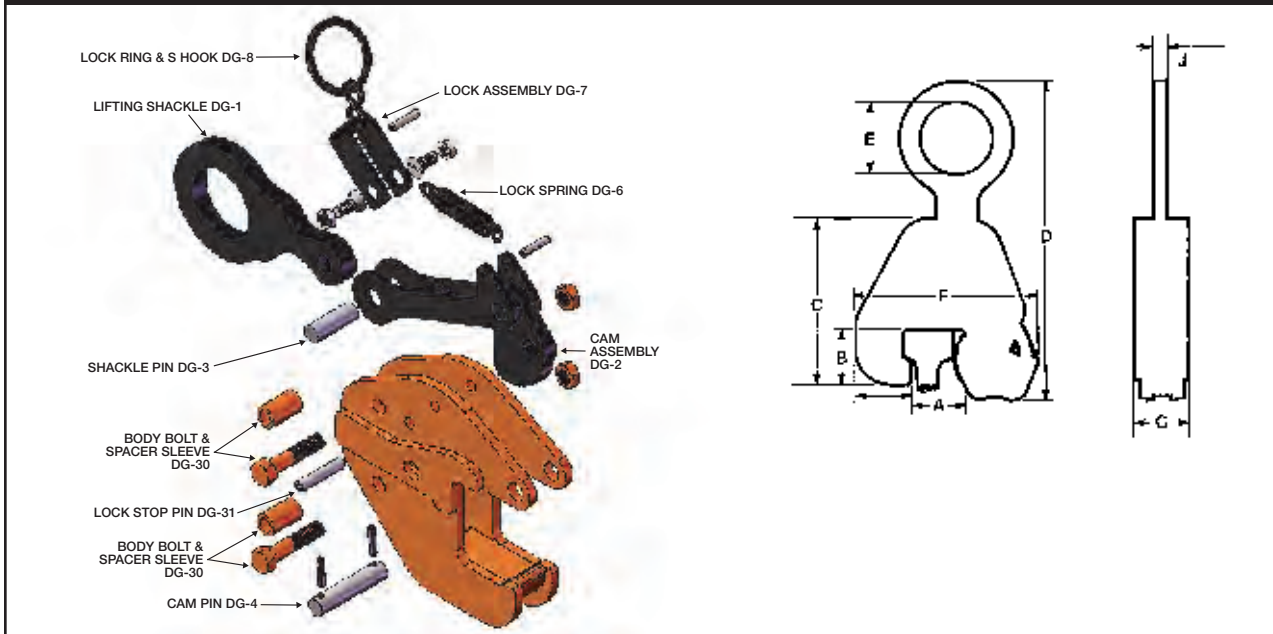

**SPECIFICATIONS** (in inches)

Rated Capacity Tons	Model	Capacity Std. Rail A	Capacity Crane Rail A	B	C	D	E	F	G	H	J	Weight (in pounds)
1/2	25	12-25 LB.	NONE	1 <sup>5</sup> / <sub>16</sub>	6 <sup>11</sup> / <sub>16</sub>	11 <sup>1</sup> / <sub>4</sub>	2 <sup>3</sup> / <sub>8</sub>	5 <sup>3</sup> / <sub>8</sub>	2 <sup>1</sup> / <sub>2</sub>	1 <sup>5</sup> / <sub>8</sub>	1 <sup>1</sup> / <sub>2</sub>	10
1/2	50	30-50 LB.	NONE	1 <sup>3</sup> / <sub>8</sub>	6 <sup>11</sup> / <sub>16</sub>	11 <sup>1</sup> / <sub>4</sub>	2 <sup>3</sup> / <sub>8</sub>	6	2 <sup>1</sup> / <sub>2</sub>	1 <sup>5</sup> / <sub>8</sub>	1 <sup>1</sup> / <sub>2</sub>	11
1	132	85-155 LB.	NONE	2 <sup>1</sup> / <sub>2</sub>	8 <sup>1</sup> / <sub>8</sub>	13 <sup>1</sup> / <sub>2</sub>	2 <sup>5</sup> / <sub>8</sub>	8 <sup>5</sup> / <sub>8</sub>	3 <sup>1</sup> / <sub>4</sub>	1 <sup>7</sup> / <sub>8</sub>	5 <sup>5</sup> / <sub>8</sub>	16
2	105	60-155 LB.	104 & 105 LB.	2 <sup>5</sup> / <sub>8</sub>	9	16	3 <sup>5</sup> / <sub>8</sub>	9 <sup>1</sup> / <sub>8</sub>	3 <sup>1</sup> / <sub>4</sub>	2 <sup>1</sup> / <sub>2</sub>	3 <sup>3</sup> / <sub>4</sub>	26
2	175	NONE	135, 171, 175 LB.	2 <sup>5</sup> / <sub>8</sub>	9 <sup>1</sup> / <sub>2</sub>	16	3 <sup>5</sup> / <sub>8</sub>	10 <sup>3</sup> / <sub>8</sub>	3 <sup>1</sup> / <sub>4</sub>	2 <sup>1</sup> / <sub>2</sub>	3 <sup>3</sup> / <sub>4</sub>	26

SPECIFICATIONS ARE SUBJECT TO CHANGE WITHOUT NOTICE. OTHER CAPACITIES AVAILABLE UPON REQUEST.



## Model M Locking Type



The **Model M** is a multipurpose clamp used for positioning, sorting, erection and handling of prefabricated sections. The split lower jaw enables the clamp to be particularly useful in handling structural shapes. The **Model M** incorporates a "Lock Closed" feature which facilitates attaching the clamp to the member being lifted. These clamps must be used in pairs, sets of pairs, or in a tripod arrangement for transporting plate horizontally. Handle is available on 8 ton clamp only.

### MODEL M EXPLODED VIEW

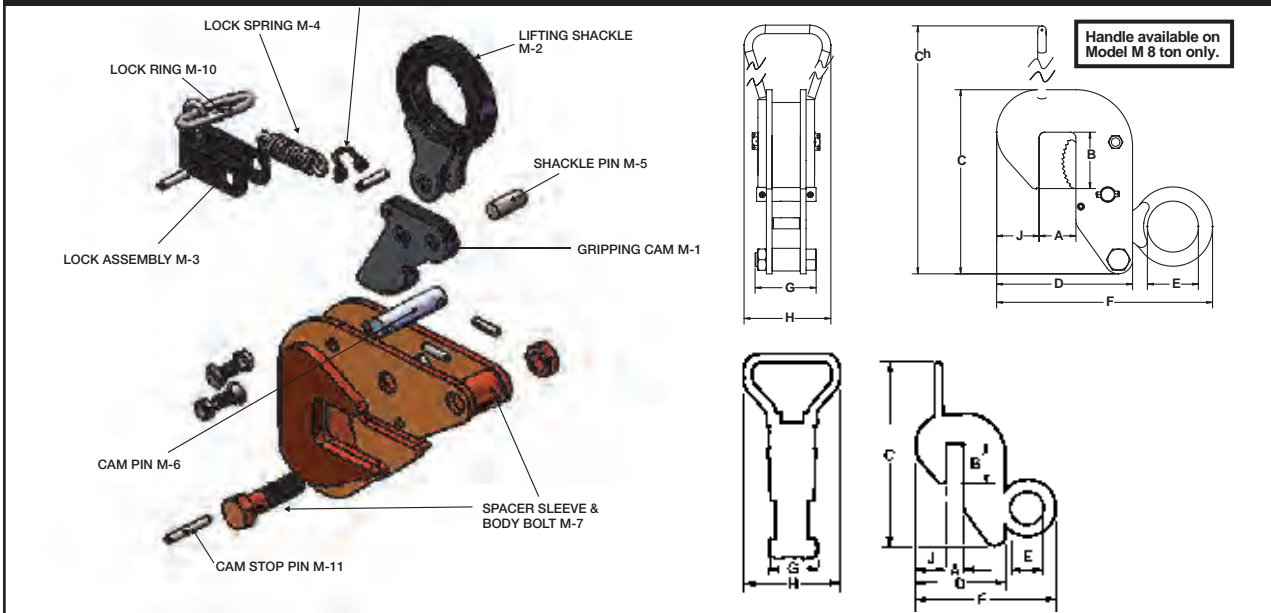

#### SPECIFICATIONS (in inches)

Rated Capacity Tons	Plate Thickness A	B	C	Ch	D	MAX. E	F	G	H	J	Weight (in pounds)
<b>1/2</b>	0-1	2 <sup>5</sup> / <sub>16</sub>	7 <sup>7</sup> / <sub>16</sub>	—	4 <sup>1</sup> / <sub>16</sub>	2 <sup>1</sup> / <sub>4</sub>	8 <sup>7</sup> / <sub>8</sub>	2 <sup>5</sup> / <sub>8</sub>	—	1 <sup>7</sup> / <sub>16</sub>	7
	3/4-1 <sup>1</sup> / <sub>2</sub>	2 <sup>5</sup> / <sub>16</sub>	7 <sup>1</sup> / <sub>16</sub>	—	5 <sup>3</sup> / <sub>16</sub>	2 <sup>1</sup> / <sub>4</sub>	9 <sup>3</sup> / <sub>8</sub>	2 <sup>5</sup> / <sub>8</sub>	—	1 <sup>7</sup> / <sub>16</sub>	8
	1 <sup>1</sup> / <sub>4</sub> -2	2 <sup>5</sup> / <sub>16</sub>	7 <sup>1</sup> / <sub>16</sub>	—	5 <sup>11</sup> / <sub>16</sub>	2 <sup>1</sup> / <sub>4</sub>	9 <sup>7</sup> / <sub>8</sub>	2 <sup>5</sup> / <sub>8</sub>	—	1 <sup>7</sup> / <sub>16</sub>	9
<b>1</b>	0-1	2 <sup>1</sup> / <sub>2</sub>	8 <sup>1</sup> / <sub>8</sub>	—	5 <sup>1</sup> / <sub>2</sub>	2 <sup>1</sup> / <sub>4</sub>	9 <sup>1</sup> / <sub>2</sub>	2 <sup>3</sup> / <sub>4</sub>	—	1 <sup>7</sup> / <sub>8</sub>	11
	3/4-1 <sup>1</sup> / <sub>2</sub>	2 <sup>1</sup> / <sub>2</sub>	8 <sup>1</sup> / <sub>8</sub>	—	6	2 <sup>1</sup> / <sub>4</sub>	10	2 <sup>3</sup> / <sub>4</sub>	—	1 <sup>7</sup> / <sub>8</sub>	12
	1 <sup>1</sup> / <sub>4</sub> -2	2 <sup>1</sup> / <sub>2</sub>	8 <sup>1</sup> / <sub>8</sub>	—	6 <sup>1</sup> / <sub>2</sub>	2 <sup>1</sup> / <sub>4</sub>	10 <sup>1</sup> / <sub>2</sub>	2 <sup>3</sup> / <sub>4</sub>	—	1 <sup>7</sup> / <sub>8</sub>	13
<b>2</b>	0-1 <sup>1</sup> / <sub>4</sub>	3 <sup>3</sup> / <sub>16</sub>	10 <sup>3</sup> / <sub>4</sub>	—	6 <sup>9</sup> / <sub>16</sub>	3 <sup>1</sup> / <sub>16</sub>	12 <sup>1</sup> / <sub>8</sub>	3 <sup>7</sup> / <sub>8</sub>	—	2	23
	1-2	3 <sup>3</sup> / <sub>16</sub>	10 <sup>3</sup> / <sub>4</sub>	—	7 <sup>3</sup> / <sub>16</sub>	3 <sup>1</sup> / <sub>16</sub>	12 <sup>1</sup> / <sub>8</sub>	3 <sup>7</sup> / <sub>8</sub>	—	2	24
	1 <sup>3</sup> / <sub>4</sub> -2 <sup>3</sup> / <sub>4</sub>	3 <sup>3</sup> / <sub>16</sub>	10 <sup>3</sup> / <sub>4</sub>	—	7 <sup>15</sup> / <sub>16</sub>	3 <sup>1</sup> / <sub>16</sub>	13 <sup>5</sup> / <sub>8</sub>	3 <sup>7</sup> / <sub>8</sub>	—	2	27
<b>4</b>	0-1 <sup>1</sup> / <sub>2</sub>	3 <sup>13</sup> / <sub>16</sub>	12	—	7 <sup>3</sup> / <sub>4</sub>	3 <sup>5</sup> / <sub>8</sub>	14 <sup>1</sup> / <sub>2</sub>	4 <sup>3</sup> / <sub>8</sub>	—	2 <sup>3</sup> / <sub>4</sub>	36
	1 <sup>1</sup> / <sub>4</sub> -2 <sup>1</sup> / <sub>2</sub>	3 <sup>13</sup> / <sub>16</sub>	12	—	8 <sup>3</sup> / <sub>4</sub>	3 <sup>5</sup> / <sub>8</sub>	16 <sup>1</sup> / <sub>2</sub>	4 <sup>3</sup> / <sub>8</sub>	—	2 <sup>3</sup> / <sub>4</sub>	38
	2 <sup>1</sup> / <sub>4</sub> -3 <sup>1</sup> / <sub>2</sub>	3 <sup>13</sup> / <sub>16</sub>	12	—	9 <sup>3</sup> / <sub>4</sub>	3 <sup>5</sup> / <sub>8</sub>	14 <sup>1</sup> / <sub>2</sub>	4 <sup>3</sup> / <sub>8</sub>	—	2 <sup>3</sup> / <sub>4</sub>	41
<b>8</b>	0-2	4 <sup>15</sup> / <sub>16</sub>	—	19 <sup>1</sup> / <sub>4</sub>	11 <sup>7</sup> / <sub>16</sub>	4	19 <sup>1</sup> / <sub>2</sub>	5 <sup>1</sup> / <sub>2</sub>	8	4	107
	1 <sup>3</sup> / <sub>4</sub> -3 <sup>1</sup> / <sub>2</sub>	4 <sup>15</sup> / <sub>16</sub>	—	19 <sup>1</sup> / <sub>4</sub>	12 <sup>15</sup> / <sub>16</sub>	4	21	5 <sup>1</sup> / <sub>2</sub>	8	4	110
	3 <sup>1</sup> / <sub>4</sub> -5	4 <sup>15</sup> / <sub>16</sub>	—	19 <sup>1</sup> / <sub>4</sub>	14 <sup>7</sup> / <sub>16</sub>	4	22 <sup>1</sup> / <sub>2</sub>	5 <sup>1</sup> / <sub>2</sub>	8	4	125

SPECIFICATIONS ARE SUBJECT TO CHANGE WITHOUT NOTICE

# Model SEA

## Locking Type



The **Model SEA** is a clamp used primarily for erection of structural beams. Configuration of the lower hook assembly and the over center position of the shackle permits a clamp to grip closer to the beam web, stabilizing the load and holding it with the web near horizontal for easy alignment of bolt holes.

The clamp incorporates a "Lock Open" and "Lock Closed" feature which facilitates in attaching and removing the clamp from the beam.

### MODEL SEA EXPLODED VIEW

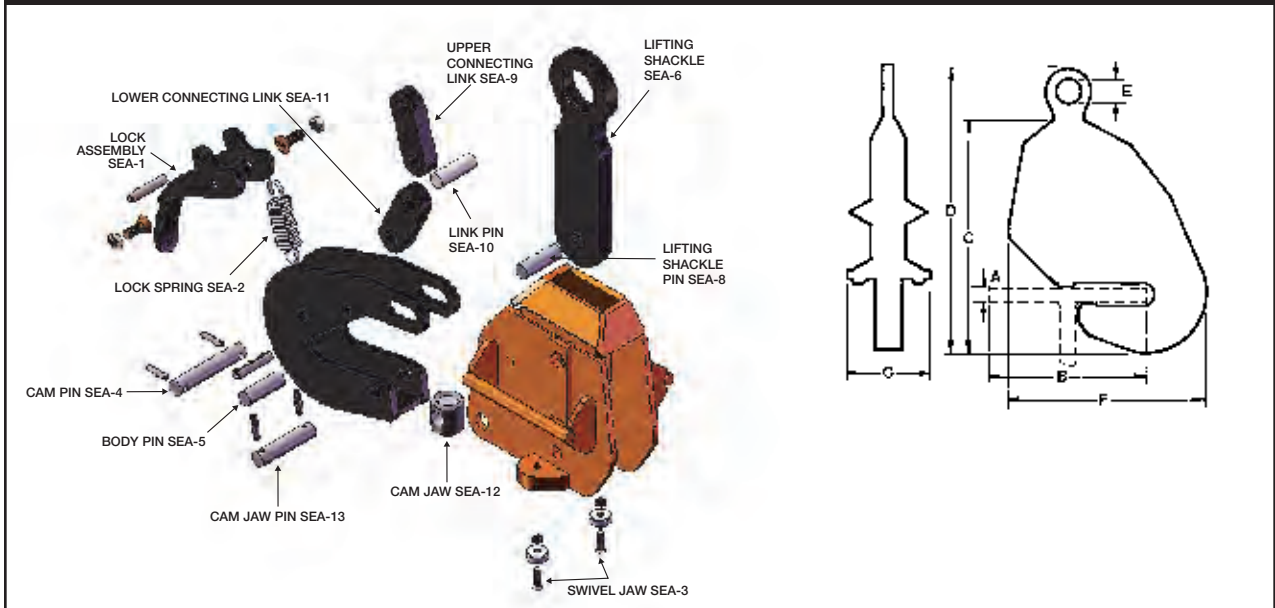

**SPECIFICATIONS** (in inches)

Rated Capacity Tons	Plate Thickness A	Flange Width B	C	Max. D	E	F	G	Weight (in pounds)
1	0- <sup>3</sup> / <sub>4</sub>	3-8	11 <sup>5</sup> / <sub>16</sub>	17 <sup>1</sup> / <sub>8</sub>	1 <sup>1</sup> / <sub>8</sub>	9 <sup>1</sup> / <sub>4</sub>	5 <sup>7</sup> / <sub>8</sub>	22
2	0-1	5-12	17 <sup>1</sup> / <sub>2</sub>	21 <sup>1</sup> / <sub>2</sub>	1 <sup>1</sup> / <sub>2</sub>	14 <sup>1</sup> / <sub>8</sub>	6 <sup>7</sup> / <sub>8</sub>	73
4	0-1	7-14	19 <sup>3</sup> / <sub>4</sub>	27 <sup>1</sup> / <sub>2</sub>	1 <sup>3</sup> / <sub>4</sub>	17 <sup>7</sup> / <sub>8</sub>	8 <sup>11</sup> / <sub>16</sub>	116
	<sup>3</sup> / <sub>4</sub> -1 <sup>3</sup> / <sub>4</sub>	7-14	20 <sup>1</sup> / <sub>2</sub>	28 <sup>1</sup> / <sub>4</sub>	1 <sup>3</sup> / <sub>4</sub>	17 <sup>7</sup> / <sub>8</sub>	8 <sup>11</sup> / <sub>16</sub>	120
8	0-1 <sup>1</sup> / <sub>2</sub>	10-20	25 <sup>1</sup> / <sub>2</sub>	31	2	21 <sup>1</sup> / <sub>2</sub>	9 <sup>3</sup> / <sub>4</sub>	200
	1-2 <sup>1</sup> / <sub>2</sub>	10-20	26 <sup>1</sup> / <sub>2</sub>	32	2	21 <sup>1</sup> / <sub>2</sub>	9 <sup>3</sup> / <sub>4</sub>	204
15	<sup>3</sup> / <sub>4</sub> -2 <sup>1</sup> / <sub>4</sub>	10-20	31	41 <sup>1</sup> / <sub>2</sub>	3 <sup>3</sup> / <sub>4</sub>	21 <sup>1</sup> / <sub>2</sub>	10 <sup>3</sup> / <sub>4</sub>	343
	2-3 <sup>1</sup> / <sub>2</sub>	10-20	32 <sup>1</sup> / <sub>4</sub>	42 <sup>3</sup> / <sub>4</sub>	3 <sup>3</sup> / <sub>4</sub>	21 <sup>1</sup> / <sub>2</sub>	10 <sup>3</sup> / <sub>4</sub>	

SPECIFICATIONS ARE SUBJECT TO CHANGE WITHOUT NOTICE.



# Model SX

## Locking Type

The **Model SX** clamp is used for lifting and transporting of angles both in fabrication and erection of steel. It possesses all the features of the Model S. All repair parts are identical to the same tonnage Model S parts.

### MODEL SX EXPLODED VIEW

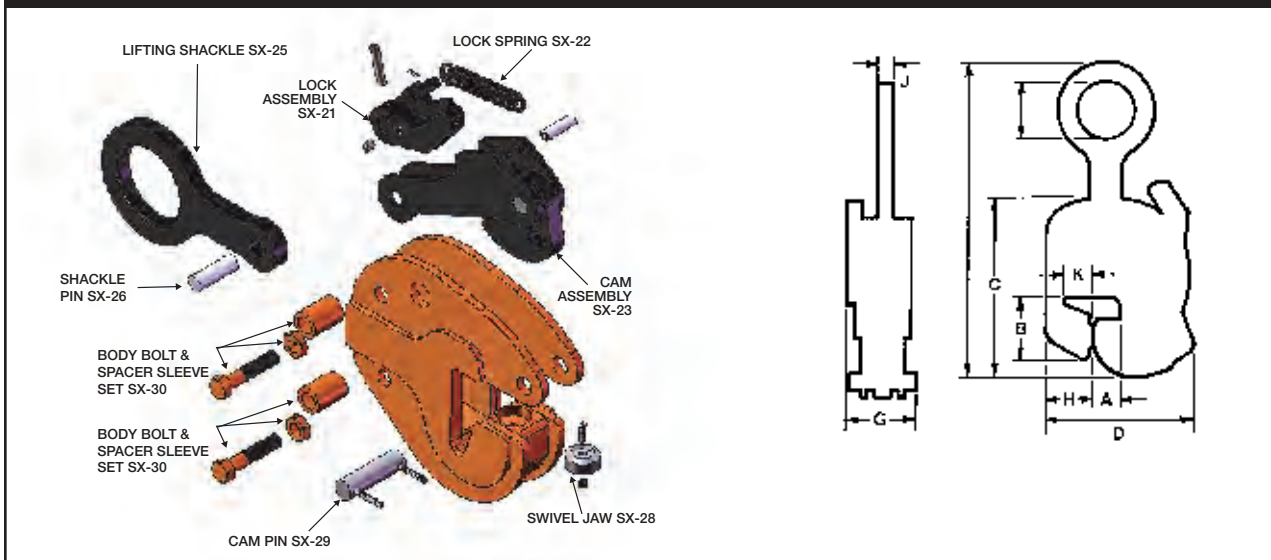

**SPECIFICATIONS** (in inches)

Rated Capacity Tons	Plate Thickness A	B	C	MAX. D	E	F	G	H	J	K	Weight (in pounds)
2	0-1	3 <sup>5</sup> / <sub>8</sub>	9 <sup>1</sup> / <sub>2</sub>	18 <sup>1</sup> / <sub>2</sub>	3 <sup>1</sup> / <sub>2</sub>	9 <sup>1</sup> / <sub>4</sub>	3 <sup>3</sup> / <sub>4</sub>	4 <sup>1</sup> / <sub>8</sub>	3 <sup>3</sup> / <sub>4</sub>	2 <sup>1</sup> / <sub>2</sub>	34
	1 <sup>1</sup> / <sub>2</sub> -1 <sup>1</sup> / <sub>2</sub>	3 <sup>5</sup> / <sub>8</sub>	9 <sup>1</sup> / <sub>2</sub>	18 <sup>1</sup> / <sub>2</sub>	3 <sup>1</sup> / <sub>2</sub>	10 <sup>1</sup> / <sub>4</sub>	3 <sup>3</sup> / <sub>4</sub>	4 <sup>1</sup> / <sub>8</sub>	3 <sup>3</sup> / <sub>4</sub>	2 <sup>1</sup> / <sub>2</sub>	34
4	1 <sup>1</sup> / <sub>2</sub> -1 <sup>1</sup> / <sub>2</sub>	4 <sup>1</sup> / <sub>8</sub>	11 <sup>1</sup> / <sub>2</sub>	19 <sup>5</sup> / <sub>8</sub>	3 <sup>5</sup> / <sub>8</sub>	10 <sup>1</sup> / <sub>2</sub>	4 <sup>7</sup> / <sub>8</sub>	4 <sup>3</sup> / <sub>4</sub>	3 <sup>3</sup> / <sub>4</sub>	2 <sup>1</sup> / <sub>2</sub>	51

SPECIFICATIONS ARE SUBJECT TO CHANGE WITHOUT NOTICE.



# HORIZONTAL







# Model DWS Locking Type

Model DWS is a horizontal lifting clamp utilizing Renfro's famous "lock-closed" feature. This clamp comes in four sizes:

- 1/4 Ton: 0 – 1/2" opening
- 1/2 Ton: 0 – 3/4" opening
- 1-1/2 Ton: 0 – 1" opening
- 3 Ton: 0 – 1-1/4" opening

Recommended for use in pairs.

## MODEL DWS EXPLODED VIEW

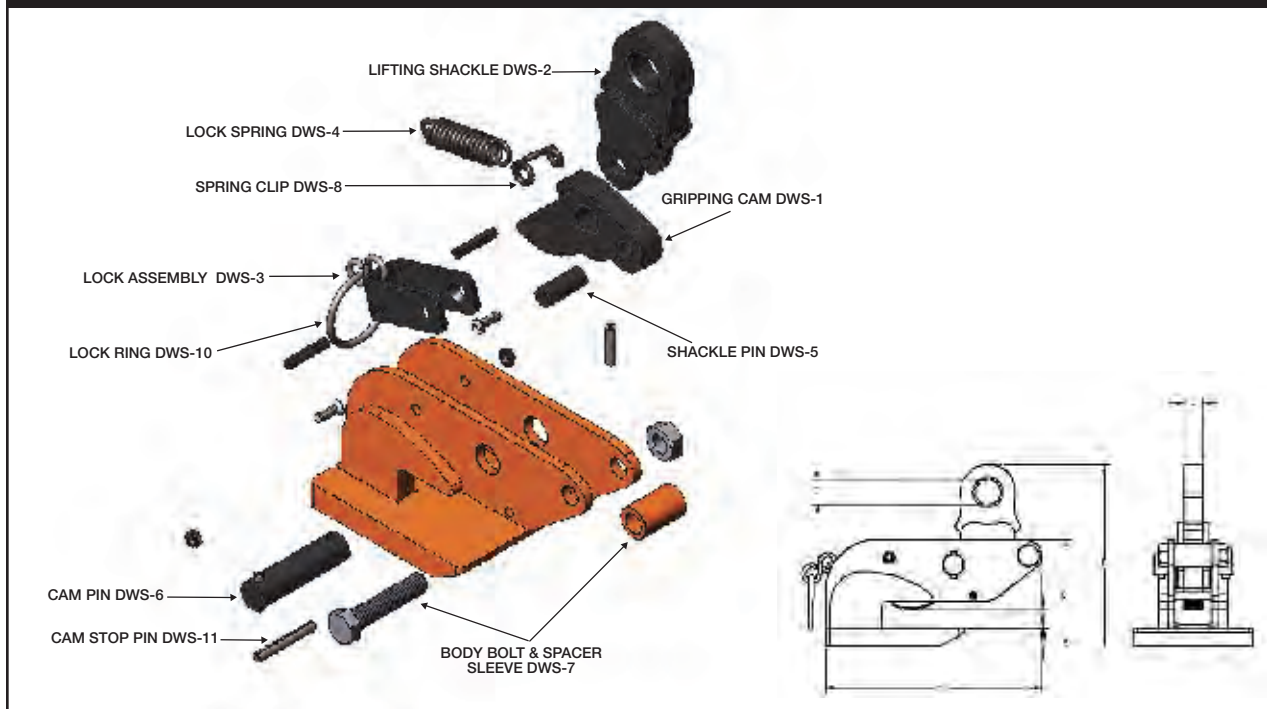

### SPECIFICATIONS (in inches)

Rated Capacity Tons	Plate Thickness A	B	C	D	Std. E	Option E	Max. F	G	H	J	Weight (in pounds)
1/4	0 - 1/2	2 7/8	6 5/8	3 3/16	3/4	2	5 3/4	3 1/2	3/8	1/2	5
1/2	0 - 3/4	3	7	3 9/16	1	2 1/4	7 3/8	4	1/2	5/8	9
1 1/2	0 - 1	3 1/2	8 1/4	4 1/4	1	2 1/4	8 1/8	5	5/8	5/8	14
3	0 - 1 1/4	4 1/2	11 3/4	5 13/16	1 1/8	3 1/2	11 3/4	6 1/2	1	1	37

SPECIFICATIONS ARE SUBJECT TO CHANGE WITHOUT NOTICE.

# Model HR Non-Locking Type



The **Model HR** is a horizontal lifting clamp intended to be used in pairs, sets of pairs, or in a tripod arrangement for transporting steel plates horizontally.

Equipped with serrated gripping cams as standard equipment, both the HR and HDR models are available with smooth, bronze or stainless steel gripping cams to prevent marring when handling polished metals such as stainless steel, copper, aluminum, etc.

## MODEL HR EXPLODED VIEW

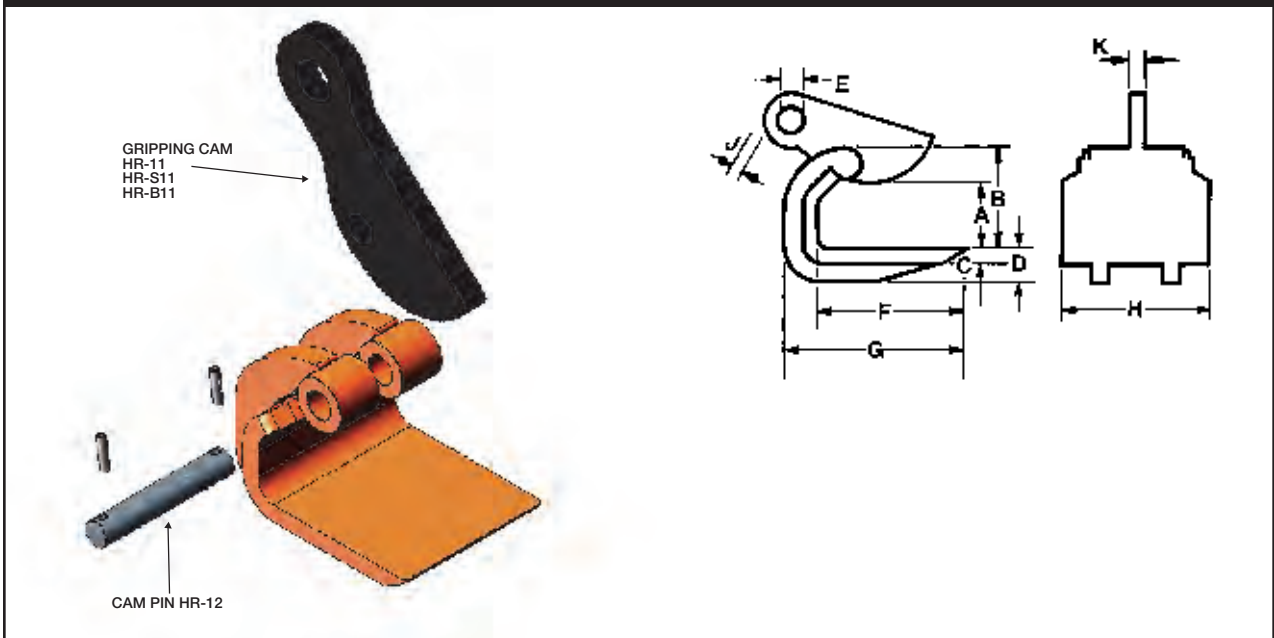

### SPECIFICATIONS (in inches)

Rated Capacity Tons	Plate Thickness A	B	C	D	E	F	G	H	Weight J	K	(in pounds)
1/4	0-1	2 <sup>3</sup> / <sub>4</sub>	1 <sup>1</sup> / <sub>2</sub>	+	1	3 <sup>9</sup> / <sub>16</sub>	4 <sup>1</sup> / <sub>16</sub>	3	3 <sup>5</sup> / <sub>16</sub>	1 <sup>1</sup> / <sub>2</sub>	3 <sup>1</sup> / <sub>2</sub>
1/2	0-2	4 <sup>1</sup> / <sub>4</sub>	1 <sup>1</sup> / <sub>2</sub>	+	1 <sup>3</sup> / <sub>8</sub>	5 <sup>5</sup> / <sub>8</sub>	6 <sup>1</sup> / <sub>8</sub>	7	3 <sup>3</sup> / <sub>4</sub>	1 <sup>1</sup> / <sub>2</sub>	14
3/4	0-2	4 <sup>3</sup> / <sub>8</sub>	5 <sup>5</sup> / <sub>8</sub>	+	1 <sup>3</sup> / <sub>8</sub>	5 <sup>5</sup> / <sub>8</sub>	6 <sup>1</sup> / <sub>4</sub>	7	3 <sup>3</sup> / <sub>4</sub>	3 <sup>3</sup> / <sub>4</sub>	19
1 1/2	0-2	4 <sup>3</sup> / <sub>8</sub>	3 <sup>3</sup> / <sub>4</sub>	+	1 <sup>3</sup> / <sub>8</sub>	5 <sup>5</sup> / <sub>8</sub>	6 <sup>3</sup> / <sub>8</sub>	7	3 <sup>3</sup> / <sub>4</sub>	3 <sup>3</sup> / <sub>4</sub>	23
3	0-2	4 <sup>5</sup> / <sub>8</sub>	5 <sup>5</sup> / <sub>8</sub>	1 <sup>5</sup> / <sub>8</sub>	1 <sup>3</sup> / <sub>8</sub>	5 <sup>5</sup> / <sub>8</sub>	7 <sup>1</sup> / <sub>4</sub>	7	3 <sup>3</sup> / <sub>4</sub>	3 <sup>3</sup> / <sub>4</sub>	24
4	0-3	5 <sup>5</sup> / <sub>8</sub>	3 <sup>3</sup> / <sub>4</sub>	2 <sup>1</sup> / <sub>8</sub>	1 <sup>3</sup> / <sub>8</sub>	7 <sup>1</sup> / <sub>2</sub>	9 <sup>5</sup> / <sub>8</sub>	7	1 <sup>1</sup> / <sub>8</sub>	1	44

SPECIFICATIONS ARE SUBJECT TO CHANGE WITHOUT NOTICE. + No backpad on capacities 1/4 ton thru 1 1/2 ton.



## Model HDR Non-Locking Type

The **Model HDR** is a horizontal lifting clamp intended to be used in pairs, sets of pairs, or in a tripod arrangement for transporting steel plates horizontally. The **Model HDR** is similar to the **Model HR** except that it contains dual cam assemblies which provide two gripping surfaces.

Equipped with serrated gripping cams as standard equipment, both the HR and HDR models are available with smooth, bronze or stainless steel gripping cams to prevent marring when handling polished metals such as stainless steel, copper, aluminum, etc.

### MODEL HDR EXPLODED VIEW

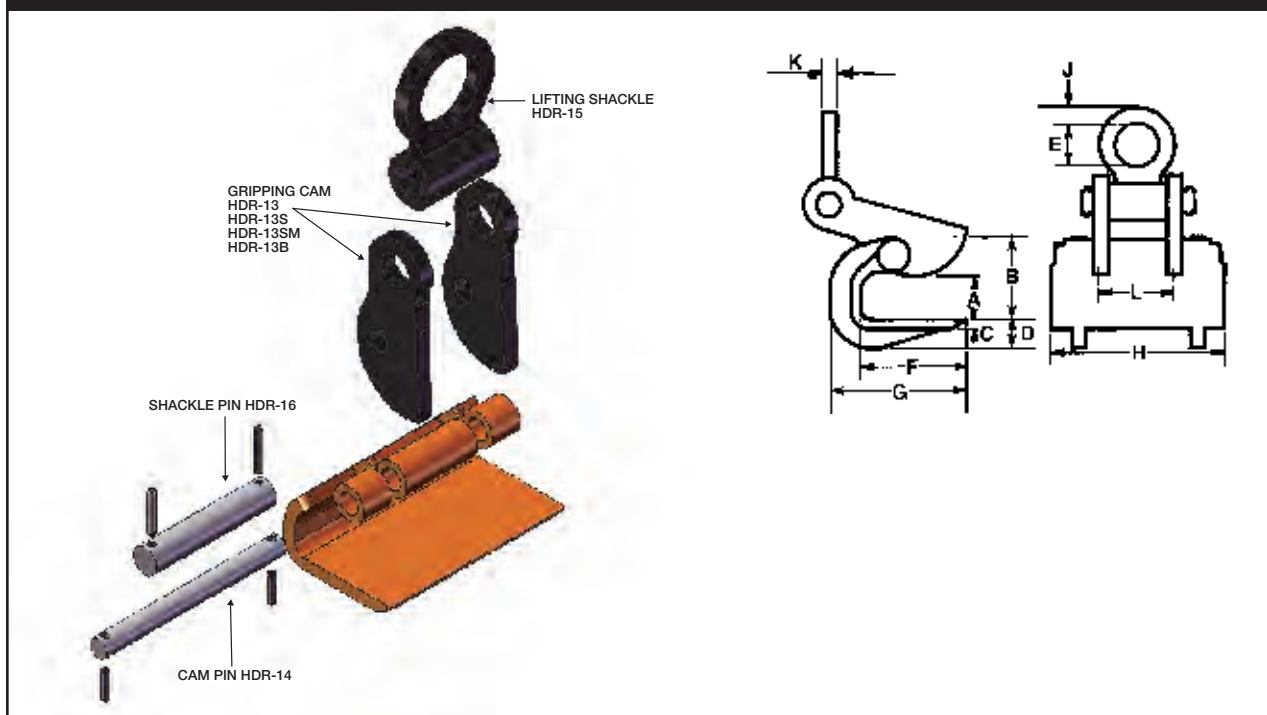

HORIZONTAL

#### SPECIFICATIONS (in inches)

Rated Capacity Tons	Plate Thickness A	B	C	D	E	F	G	H	Weight			
									J	K	L (in pounds)	
1½	0-2	4¾	5/8	+	3¼	5½	6¼	12	15/16	¾	5	44
3	0-2	4¾	¾	+	3¼	5½	6¾	12	15/16	¾	5	48
6	0-2	4¾	5/8	1½	3¼	5½	7¼	12	15/16	1½	5	53
8	0-3	5¾	¾	2½	3¼	7½	9¾	12¼	15/16	1½	5¼	84

SPECIFICATIONS ARE SUBJECT TO CHANGE WITHOUT NOTICE. + No backpad on 1½ or 3 ton models.

# Model HRS

## Locking Type



The **Model HRS** is a horizontal lifting clamp that has a spring loaded open and closed position. The spring closed position allows one-man operation of multiple clamps. The clamps stay in position where they're attached until spring open is actuated.

These clamps must be used in pairs, sets of pairs, or in a tripod arrangement for transporting plate horizontally.

### MODEL HRS EXPLODED VIEW

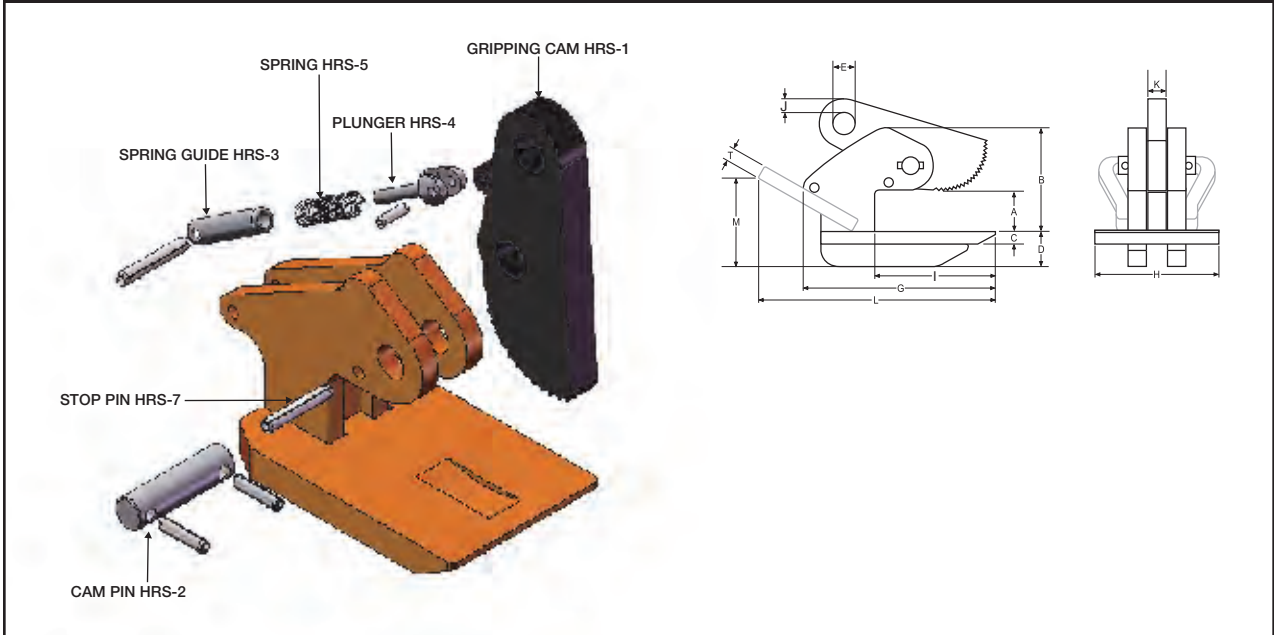

**SPECIFICATIONS** (in inches)

Rated Capacity Tons	Plate Thickness A	B	C	D	E	F	G	H	J	K	Weight			T (in pounds)
											L	M		
1/4	1/16-3/4	2 5/16	3/8	-	1/2	3	4 3/4	3	1/4	1/2	-	-	-	4
1/2	1/16-1	3 5/16	1/2	-	1/2	3 3/4	5 15/16	3 1/4	5/16	1/2	-	-	-	5
1	1/16-1 1/4	3 11/16	5/8	-	5/8	4	6 3/16	3 1/2	7/16	5/8	-	-	-	7
2	1/16-1 1/2	4 1/2	3/4	-	1 1/16	5 3/8	8 5/8	5	9/16	3/4	10 15/16	3 1/4	5/8	20
3	1/16-1 3/4	5 3/4	1	-	1 1/4	6 3/4	10 3/4	7	3/4	1	13	4	5/8	34
4	1/16-2	5 3/4	3/4	2	1 1/4	6 3/4	10 3/4	7	3/4	1	13 5/16	5	3/4	44

SPECIFICATIONS ARE SUBJECT TO CHANGE WITHOUT NOTICE.

**Backpad available only on 4 ton model. Handles are standard on 2, 3 and 4 ton models.**



## Model M Locking Type



The **Model M** is shown with the structural shape lifting clamps but can also be used for horizontal lifting of plates and structural beams. The **Model M** incorporates a “Lock Closed” feature which facilitates attaching the clamp to the member being lifted. These clamps must be used in pairs, sets of pairs, or in a tripod arrangement for transporting plate horizontally. Handle is available on 8 ton clamp only.

### MODEL M EXPLODED VIEW

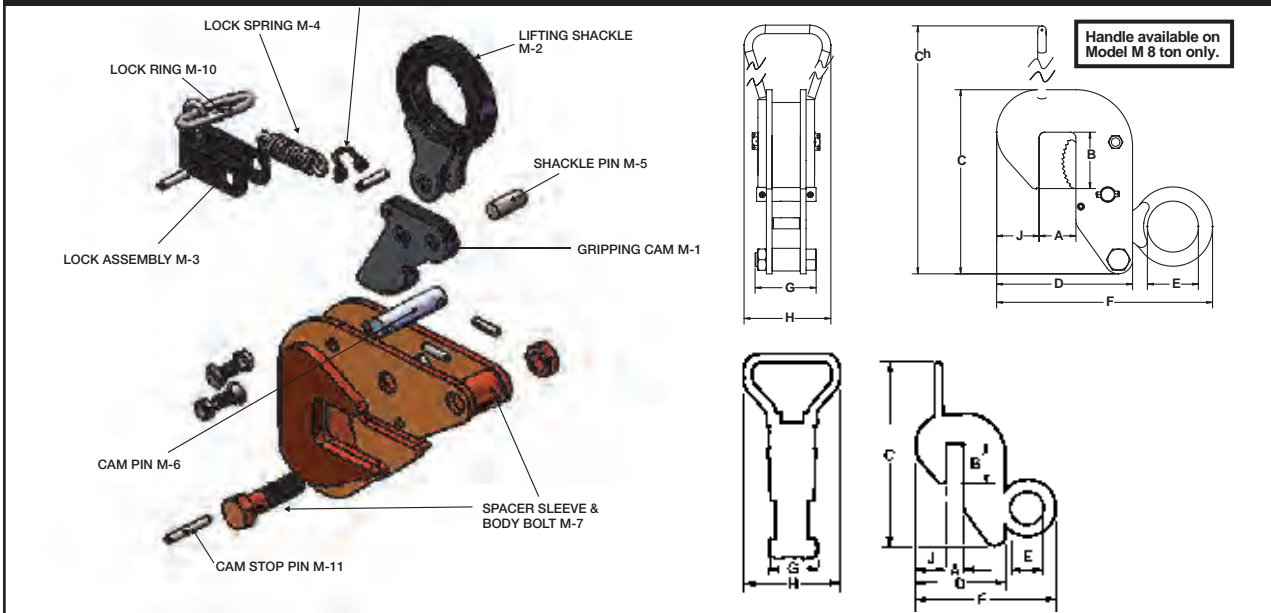

#### SPECIFICATIONS (in inches)

Rated Capacity Tons	Plate Thickness A	B	C	Ch	D	MAX. E	F	G	H	J	Weight (in pounds)
<b>1/2</b>	0-1	2 <sup>5</sup> / <sub>16</sub>	7 <sup>7</sup> / <sub>16</sub>	—	4 <sup>1</sup> / <sub>16</sub>	2 <sup>1</sup> / <sub>4</sub>	8 <sup>7</sup> / <sub>8</sub>	2 <sup>5</sup> / <sub>8</sub>	—	1 <sup>7</sup> / <sub>16</sub>	7
	3/4-1 <sup>1</sup> / <sub>2</sub>	2 <sup>5</sup> / <sub>16</sub>	7 <sup>1</sup> / <sub>16</sub>	—	5 <sup>3</sup> / <sub>16</sub>	2 <sup>1</sup> / <sub>4</sub>	9 <sup>3</sup> / <sub>8</sub>	2 <sup>5</sup> / <sub>8</sub>	—	1 <sup>7</sup> / <sub>16</sub>	8
	1 <sup>1</sup> / <sub>4</sub> -2	2 <sup>5</sup> / <sub>16</sub>	7 <sup>1</sup> / <sub>16</sub>	—	5 <sup>11</sup> / <sub>16</sub>	2 <sup>1</sup> / <sub>4</sub>	9 <sup>7</sup> / <sub>8</sub>	2 <sup>5</sup> / <sub>8</sub>	—	1 <sup>7</sup> / <sub>16</sub>	9
<b>1</b>	0-1	2 <sup>1</sup> / <sub>2</sub>	8 <sup>1</sup> / <sub>8</sub>	—	5 <sup>1</sup> / <sub>2</sub>	2 <sup>1</sup> / <sub>4</sub>	9 <sup>1</sup> / <sub>2</sub>	2 <sup>3</sup> / <sub>4</sub>	—	1 <sup>7</sup> / <sub>8</sub>	11
	3/4-1 <sup>1</sup> / <sub>2</sub>	2 <sup>1</sup> / <sub>2</sub>	8 <sup>1</sup> / <sub>8</sub>	—	6	2 <sup>1</sup> / <sub>4</sub>	10	2 <sup>3</sup> / <sub>4</sub>	—	1 <sup>7</sup> / <sub>8</sub>	12
	1 <sup>1</sup> / <sub>4</sub> -2	2 <sup>1</sup> / <sub>2</sub>	8 <sup>1</sup> / <sub>8</sub>	—	6 <sup>1</sup> / <sub>2</sub>	2 <sup>1</sup> / <sub>4</sub>	10 <sup>1</sup> / <sub>2</sub>	2 <sup>3</sup> / <sub>4</sub>	—	1 <sup>7</sup> / <sub>8</sub>	13
<b>2</b>	0-1 <sup>1</sup> / <sub>4</sub>	3 <sup>3</sup> / <sub>16</sub>	10 <sup>3</sup> / <sub>4</sub>	—	6 <sup>9</sup> / <sub>16</sub>	3 <sup>1</sup> / <sub>16</sub>	12 <sup>1</sup> / <sub>8</sub>	3 <sup>7</sup> / <sub>8</sub>	—	2	23
	1-2	3 <sup>3</sup> / <sub>16</sub>	10 <sup>3</sup> / <sub>4</sub>	—	7 <sup>3</sup> / <sub>16</sub>	3 <sup>1</sup> / <sub>16</sub>	12 <sup>5</sup> / <sub>8</sub>	3 <sup>7</sup> / <sub>8</sub>	—	2	24
	1 <sup>3</sup> / <sub>4</sub> -2 <sup>3</sup> / <sub>4</sub>	3 <sup>3</sup> / <sub>16</sub>	10 <sup>3</sup> / <sub>4</sub>	—	7 <sup>15</sup> / <sub>16</sub>	3 <sup>1</sup> / <sub>16</sub>	13 <sup>5</sup> / <sub>8</sub>	3 <sup>7</sup> / <sub>8</sub>	—	2	27
<b>4</b>	0-1 <sup>1</sup> / <sub>2</sub>	3 <sup>13</sup> / <sub>16</sub>	12	—	7 <sup>3</sup> / <sub>4</sub>	3 <sup>5</sup> / <sub>8</sub>	14 <sup>1</sup> / <sub>2</sub>	4 <sup>3</sup> / <sub>8</sub>	—	2 <sup>3</sup> / <sub>4</sub>	36
	1 <sup>1</sup> / <sub>4</sub> -2 <sup>1</sup> / <sub>2</sub>	3 <sup>13</sup> / <sub>16</sub>	12	—	8 <sup>3</sup> / <sub>4</sub>	3 <sup>5</sup> / <sub>8</sub>	16 <sup>1</sup> / <sub>2</sub>	4 <sup>3</sup> / <sub>8</sub>	—	2 <sup>3</sup> / <sub>4</sub>	38
	2 <sup>1</sup> / <sub>4</sub> -3 <sup>1</sup> / <sub>2</sub>	3 <sup>13</sup> / <sub>16</sub>	12	—	9 <sup>3</sup> / <sub>4</sub>	3 <sup>5</sup> / <sub>8</sub>	14 <sup>1</sup> / <sub>2</sub>	4 <sup>3</sup> / <sub>8</sub>	—	2 <sup>3</sup> / <sub>4</sub>	41
<b>8</b>	0-2	4 <sup>15</sup> / <sub>16</sub>	—	19 <sup>1</sup> / <sub>4</sub>	11 <sup>7</sup> / <sub>16</sub>	4	19 <sup>1</sup> / <sub>2</sub>	5 <sup>1</sup> / <sub>2</sub>	8	4	107
	1 <sup>3</sup> / <sub>4</sub> -3 <sup>1</sup> / <sub>2</sub>	4 <sup>15</sup> / <sub>16</sub>	—	19 <sup>1</sup> / <sub>4</sub>	12 <sup>15</sup> / <sub>16</sub>	4	21	5 <sup>1</sup> / <sub>2</sub>	8	4	110
	3 <sup>1</sup> / <sub>4</sub> -5	4 <sup>15</sup> / <sub>16</sub>	—	19 <sup>1</sup> / <sub>4</sub>	14 <sup>7</sup> / <sub>16</sub>	4	22 <sup>1</sup> / <sub>2</sub>	5 <sup>1</sup> / <sub>2</sub>	8	4	125

SPECIFICATIONS ARE SUBJECT TO CHANGE WITHOUT NOTICE

# Model WHSR Non-Locking Type



The **Model WHSR** is an adjustable, horizontal clamp intended to be used in pairs, sets of pairs, or in a tripod arrangement for transporting steel plates horizontally. In addition to incorporating two gripping cams, the jaw opening may be adjusted by the positioning of a pin in the body of the clamp. The gripping cams are spring loaded to remain in the "open" position until the load is applied. This feature permits the clamp to be easily applied and removed from the load. Normally furnished with serrated gripping surfaces, it is available with smooth faced bronze or stainless steel surfaces to prevent marring when handling polished plates.

## MODEL WHSR EXPLODED VIEW

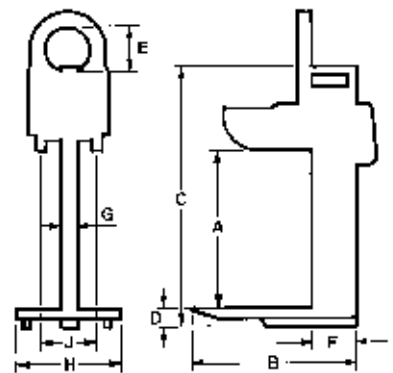
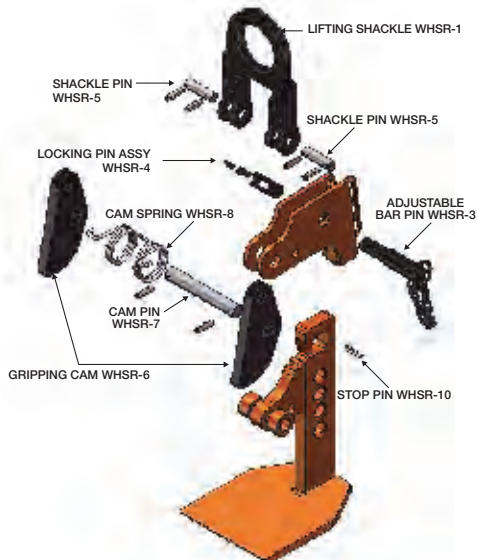

### SPECIFICATIONS (in inches)

Rated Capacity Tons	Plate Thickness A	B	C	D	E	F	G	H	J	Weight (in pounds)
<b>1/2</b>	0-6	10 <sup>3</sup> / <sub>4</sub>	14 <sup>3</sup> / <sub>16</sub>	<sup>5</sup> / <sub>8</sub>	3 <sup>1</sup> / <sub>2</sub>	3	<sup>1</sup> / <sub>2</sub>	8 <sup>3</sup> / <sub>8</sub>	4 <sup>1</sup> / <sub>2</sub>	46
	0-12	13	23 <sup>1</sup> / <sub>8</sub>	<sup>5</sup> / <sub>8</sub>	3 <sup>1</sup> / <sub>2</sub>	5	<sup>1</sup> / <sub>2</sub>	8 <sup>1</sup> / <sub>4</sub>	4 <sup>1</sup> / <sub>2</sub>	60
	0-16	13	27 <sup>3</sup> / <sub>16</sub>	<sup>5</sup> / <sub>8</sub>	3 <sup>1</sup> / <sub>2</sub>	5	<sup>1</sup> / <sub>2</sub>	8 <sup>1</sup> / <sub>4</sub>	4 <sup>1</sup> / <sub>2</sub>	80
<b>1 1/2</b>	0-6	10 <sup>3</sup> / <sub>4</sub>	14 <sup>5</sup> / <sub>16</sub>	<sup>3</sup> / <sub>4</sub>	3 <sup>1</sup> / <sub>2</sub>	3	<sup>3</sup> / <sub>4</sub>	8 <sup>3</sup> / <sub>8</sub>	4 <sup>5</sup> / <sub>8</sub>	66
	0-12	13	23 <sup>1</sup> / <sub>4</sub>	<sup>3</sup> / <sub>4</sub>	3 <sup>1</sup> / <sub>2</sub>	5	<sup>3</sup> / <sub>4</sub>	8 <sup>1</sup> / <sub>4</sub>	4 <sup>5</sup> / <sub>8</sub>	90
	0-16	13	27 <sup>5</sup> / <sub>16</sub>	<sup>3</sup> / <sub>4</sub>	3 <sup>1</sup> / <sub>2</sub>	5	<sup>3</sup> / <sub>4</sub>	8 <sup>1</sup> / <sub>4</sub>	4 <sup>5</sup> / <sub>8</sub>	104
<b>3</b>	0-6	10 <sup>3</sup> / <sub>4</sub>	15 <sup>1</sup> / <sub>4</sub>	1 <sup>5</sup> / <sub>8</sub>	3 <sup>1</sup> / <sub>2</sub>	3	1	8 <sup>3</sup> / <sub>8</sub>	4 <sup>5</sup> / <sub>8</sub>	70
	0-12	13	23 <sup>5</sup> / <sub>16</sub>	1 <sup>5</sup> / <sub>8</sub>	3 <sup>1</sup> / <sub>2</sub>	5	1	8 <sup>1</sup> / <sub>4</sub>	4 <sup>5</sup> / <sub>8</sub>	94
	0-16	13	27 <sup>13</sup> / <sub>16</sub>	1 <sup>5</sup> / <sub>8</sub>	3 <sup>1</sup> / <sub>2</sub>	5	1	8 <sup>1</sup> / <sub>4</sub>	4 <sup>5</sup> / <sub>8</sub>	112
<b>6</b>	0-6	13	18 <sup>1</sup> / <sub>16</sub>	2 <sup>1</sup> / <sub>4</sub>	3 <sup>1</sup> / <sub>2</sub>	5	1	8 <sup>1</sup> / <sub>4</sub>	4 <sup>5</sup> / <sub>8</sub>	108
	0-12	13	24 <sup>13</sup> / <sub>16</sub>	2 <sup>1</sup> / <sub>4</sub>	3 <sup>1</sup> / <sub>2</sub>	5	1	8 <sup>1</sup> / <sub>4</sub>	4 <sup>5</sup> / <sub>8</sub>	114
	0-16	13	28 <sup>13</sup> / <sub>16</sub>	2 <sup>1</sup> / <sub>4</sub>	3 <sup>1</sup> / <sub>2</sub>	5	1	8 <sup>1</sup> / <sub>4</sub>	4 <sup>5</sup> / <sub>8</sub>	154
<b>8</b>	0-6	13	18 <sup>1</sup> / <sub>2</sub>	3	3 <sup>1</sup> / <sub>2</sub>	6	1	8 <sup>1</sup> / <sub>4</sub>	5 <sup>1</sup> / <sub>4</sub>	130
	0-12	13	24 <sup>7</sup> / <sub>8</sub>	3	3 <sup>1</sup> / <sub>2</sub>	6	1	8 <sup>1</sup> / <sub>4</sub>	5 <sup>1</sup> / <sub>4</sub>	141
	0-16	13	28 <sup>7</sup> / <sub>8</sub>	3	3 <sup>1</sup> / <sub>2</sub>	6	1	8 <sup>1</sup> / <sub>4</sub>	5 <sup>1</sup> / <sub>4</sub>	220

SPECIFICATIONS ARE SUBJECT TO CHANGE WITHOUT NOTICE

# BEAM





# Model A-1 Locking Type



The **Model A-1** is a portable beam clamp that provides easy suspension of hoists, from channels or angles thereby eliminating the need for nuts, bolts, shackles and so on. The **Model A-1** is designed for use on channel or angle shapes only. This model is furnished with a fluted tool steel locking wedge which holds the clamp in place on channels or angles.

## MODEL A-1 EXPLODED VIEW

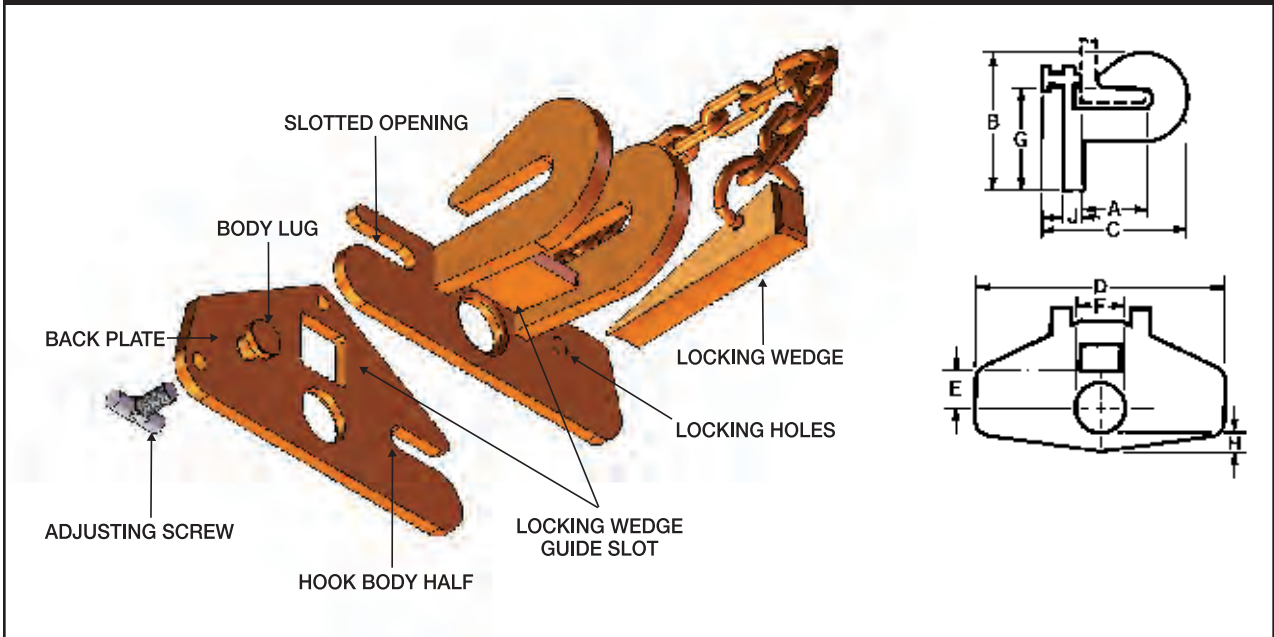

### SPECIFICATIONS (in inches)

Rated Capacity Tons	Flange Width A	B	MAX. C	D	E	F	G	H	J	Weight (in pounds)
<b>1</b>	1½-4	5 <sup>5</sup> / <sub>16</sub>	7 <sup>7</sup> / <sub>8</sub>	8 <sup>3</sup> / <sub>4</sub>	1 <sup>3</sup> / <sub>16</sub>	1½	4 <sup>3</sup> / <sub>16</sub>	5 <sup>5</sup> / <sub>8</sub>	¾	14
	4-8	6¼	12¼	8¾	1 <sup>3</sup> / <sub>16</sub>	1½	4 <sup>11</sup> / <sub>16</sub>	5 <sup>5</sup> / <sub>8</sub>	¾	15
<b>3</b>	2-4	6 <sup>11</sup> / <sub>16</sub>	8 <sup>9</sup> / <sub>16</sub>	11¼	1 <sup>11</sup> / <sub>16</sub>	2¼	5 <sup>3</sup> / <sub>8</sub>	7 <sup>7</sup> / <sub>8</sub>	¾	22
	4-8	8¼	13½	11¼	1 <sup>11</sup> / <sub>16</sub>	2¼	6½	7 <sup>7</sup> / <sub>8</sub>	¾	27
<b>5</b>	2-4	8 <sup>5</sup> / <sub>8</sub>	8 <sup>7</sup> / <sub>8</sub>	13¼	2¾	3 <sup>1</sup> / <sub>8</sub>	6 <sup>3</sup> / <sub>8</sub>	1	1	35
	4-8	10 <sup>3</sup> / <sub>16</sub>	13 <sup>13</sup> / <sub>16</sub>	13¼	2¾	3 <sup>1</sup> / <sub>8</sub>	6 <sup>7</sup> / <sub>8</sub>	1	1	45

SPECIFICATIONS ARE SUBJECT TO CHANGE WITHOUT NOTICE.



# Model AC

## Locking, Screw Type

These clamps may be used for Drifting Loads when used in pairs or multiples.

The **Models AC** and **ACP** are light weight, portable clamps that provide quick easy attachment to structural members for the use of chain falls, hoists and wire rope pullers. These clamps are of single unit construction with a quick acting hand screw to secure the clamp.

The **Model AC** has a fixed Shackle Eye. These clamps are especially useful in the construction and maintenance for shipbuilding and other industries.

### MODEL AC EXPLODED VIEW

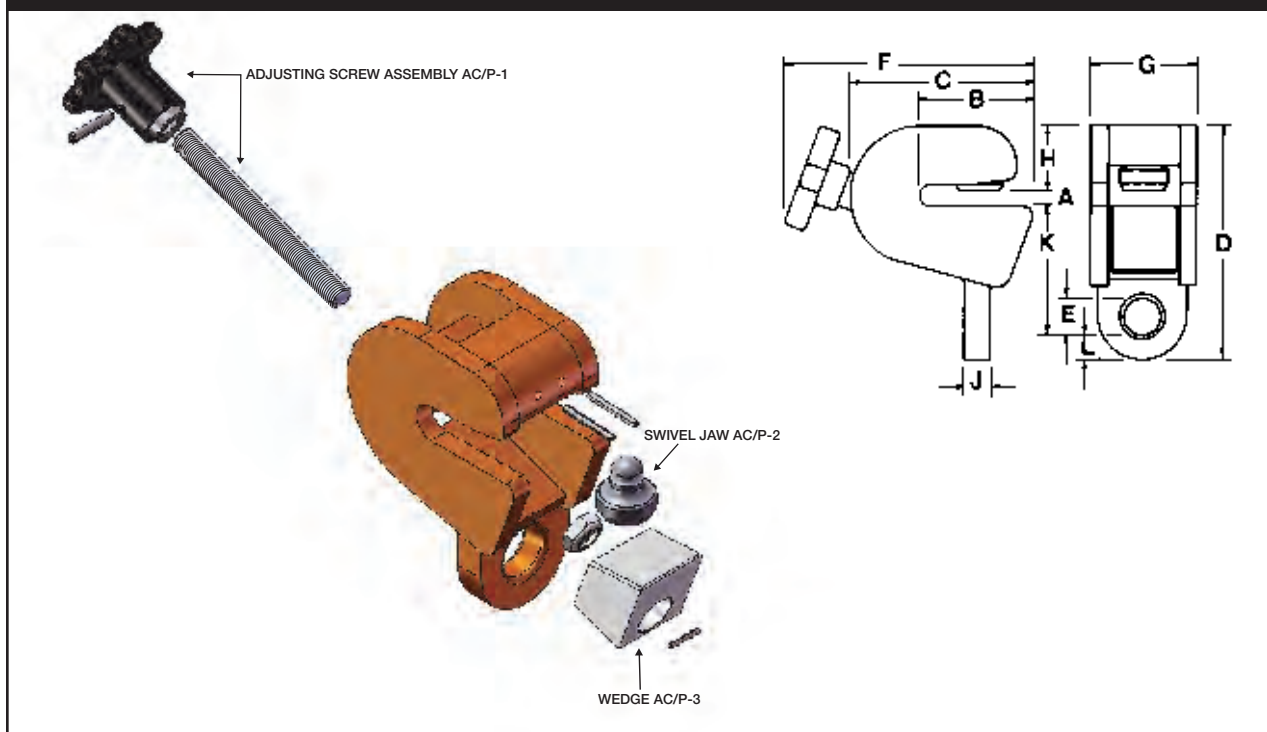

BEAM

**SPECIFICATIONS** (in inches)

Rated Capacity Tons	Flange Width A	B	C	D	E	F	G	H	Weight J	K	L	(in pounds)
2	1/4-5/8	3/4	5/4	7	1 1/4	6 3/4	3	1 13/16	3/4	3 9/16	3/4	11 1/2

SPECIFICATIONS ARE SUBJECT TO CHANGE WITHOUT NOTICE. OTHER CAPACITIES AVAILABLE UPON REQUEST.

# Model ACP

## Locking, Screw Type



These clamps may be used for Drifting Loads when used in pairs or multiples.

The **Models AC** and **ACP** are light weight, portable clamps that provide quick easy attachment to structural members for the use of chain falls, hoists and wire rope pullers. These clamps are of single unit construction with a quick acting hand screw to secure the clamp.

The **Model ACP** has a Pivoting Shackle Eye. These clamps are especially useful in the construction and maintenance for shipbuilding and other industries.

### MODEL ACP EXPLODED VIEW

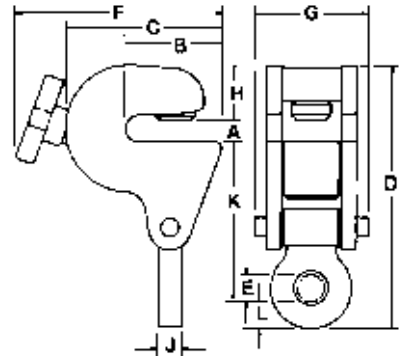
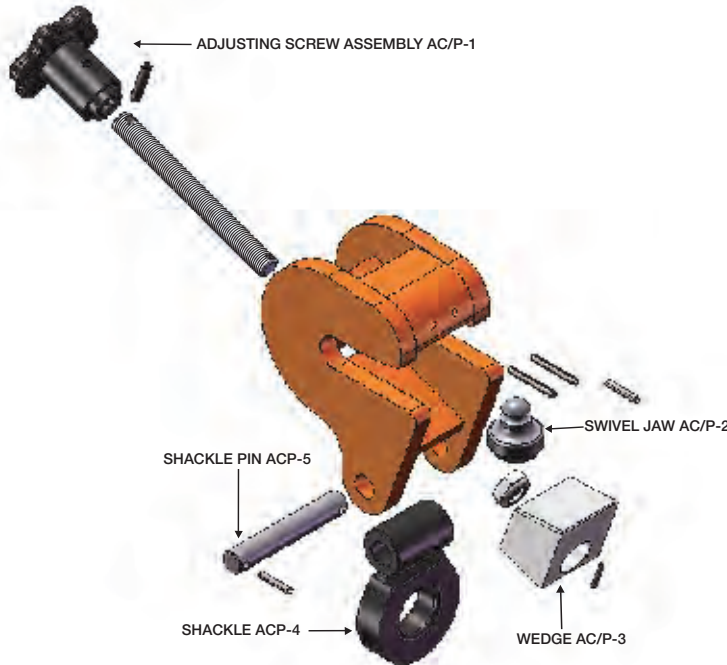

**SPECIFICATIONS** (in inches)

Rated Capacity Tons	Flange Width A	B	C	D	E	F	G	H	Weight J	K	L	(in pounds)
2	1/4-5/8	3/4	5/4	8 <sup>5</sup> / <sub>16</sub>	1 1/4	6 <sup>3</sup> / <sub>4</sub>	3 <sup>3</sup> / <sub>4</sub>	1 <sup>13</sup> / <sub>16</sub>	3/4	5 1/2	3/4	12 1/2

SPECIFICATIONS ARE SUBJECT TO CHANGE WITHOUT NOTICE. OTHER CAPACITIES AVAILABLE UPON REQUEST.



# Model B-1

## Locking Type



The **Model B-1** is a portable beam clamp that provides easy suspension of hoists from beams or girders thereby eliminating the need for nuts, bolts, shackles and so on. The **Model B-1** is intended for use on the American standard or wide flange beams. This model is furnished with a fluted tool steel locking wedge which holds the clamp in place on a beam.

### MODEL B-1 EXPLODED VIEW

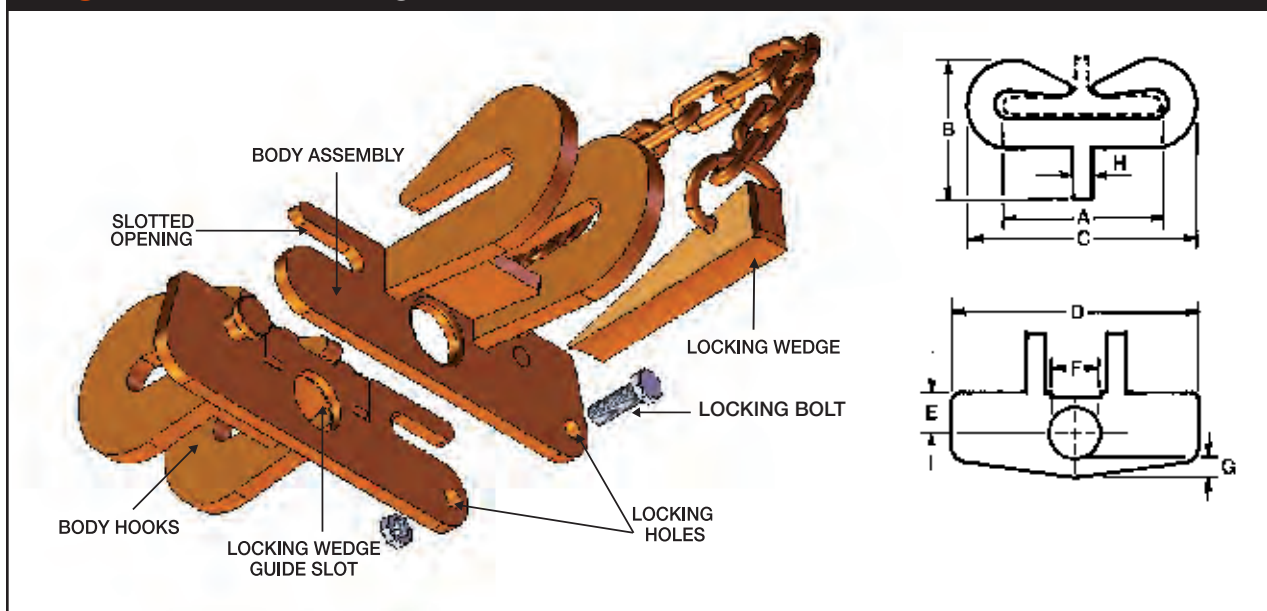

#### SPECIFICATIONS (in inches)

Rated Capacity Tons	Flange Width A	B	C	D	E	F	Weight G	H	(in pounds)
<b>1</b>	1½-4	4 <sup>21</sup> / <sub>32</sub>	6 <sup>3</sup> / <sub>4</sub>	8 <sup>3</sup> / <sub>4</sub>	1 <sup>9</sup> / <sub>16</sub>	1½	5 <sup>5</sup> / <sub>8</sub>	¾	12
	2-6	5¼	9½	8¾	1 <sup>9</sup> / <sub>16</sub>	1½	5 <sup>5</sup> / <sub>8</sub>	¾	13
	4-12	6 <sup>3</sup> / <sub>16</sub>	18 <sup>7</sup> / <sub>8</sub>	8¾	1 <sup>9</sup> / <sub>16</sub>	1½	5 <sup>5</sup> / <sub>8</sub>	¾	22
<b>3</b>	4-6	6 <sup>11</sup> / <sub>16</sub>	10 <sup>1</sup> / <sub>8</sub>	11¼	2	2¼	7 <sup>7</sup> / <sub>8</sub>	¾	20
	4-12	7 <sup>11</sup> / <sub>16</sub>	18 <sup>5</sup> / <sub>8</sub>	11¼	2	2¼	7 <sup>7</sup> / <sub>8</sub>	¾	38
<b>5</b>	4-8	9 <sup>7</sup> / <sub>16</sub>	15	14¼	3	3½	1	1	45
	4-14	9 <sup>13</sup> / <sub>16</sub>	21 <sup>3</sup> / <sub>8</sub>	14¼	3	3½	1	1	62
<b>8</b>	6-12	11 <sup>7</sup> / <sub>16</sub>	18 <sup>3</sup> / <sub>8</sub>	18 <sup>5</sup> / <sub>8</sub>	4	3½ x 4 <sup>5</sup> / <sub>8</sub>	1 <sup>7</sup> / <sub>16</sub>	1	96
	6-17	15 <sup>1</sup> / <sub>8</sub>	26¼	18 <sup>5</sup> / <sub>8</sub>	4	3½ x 4 <sup>5</sup> / <sub>8</sub>	1 <sup>7</sup> / <sub>16</sub>	1	151
	6-24	15 <sup>5</sup> / <sub>16</sub>	34 <sup>3</sup> / <sub>8</sub>	18 <sup>5</sup> / <sub>8</sub>	4	3½ x 4 <sup>5</sup> / <sub>8</sub>	1 <sup>7</sup> / <sub>16</sub>	1	207
<b>12</b>	6-12	11 <sup>15</sup> / <sub>16</sub>	19 <sup>3</sup> / <sub>8</sub>	18 <sup>5</sup> / <sub>8</sub>	4	3½ x 4 <sup>5</sup> / <sub>8</sub>	1 <sup>7</sup> / <sub>16</sub>	1¼	98
	6-17	15 <sup>5</sup> / <sub>16</sub>	26 <sup>7</sup> / <sub>8</sub>	18 <sup>5</sup> / <sub>8</sub>	4	3½ x 4 <sup>5</sup> / <sub>8</sub>	1 <sup>7</sup> / <sub>16</sub>	1¼	153
	6-24	15 <sup>13</sup> / <sub>16</sub>	34 <sup>7</sup> / <sub>8</sub>	18 <sup>5</sup> / <sub>8</sub>	4	3½ x 4 <sup>5</sup> / <sub>8</sub>	1 <sup>7</sup> / <sub>16</sub>	1¼	209

SPECIFICATIONS ARE SUBJECT TO CHANGE WITHOUT NOTICE.



# Model B-2 Trolley Clamp



The **Model B-2** is a beam trolley clamp that provides connection of a hoist or chain fall to an overhead beam and enables it to be moved along the beam as the necessity arises. Equipped with four heavy duty rollers, the **Model B-2**, with load attached, can be moved along any length of American Standard or wide flange beams. The fluted tool steel locking wedge permits the clamp to be temporarily or permanently locked at a particular position along the beam.

## MODEL B-2 EXPLODED VIEW

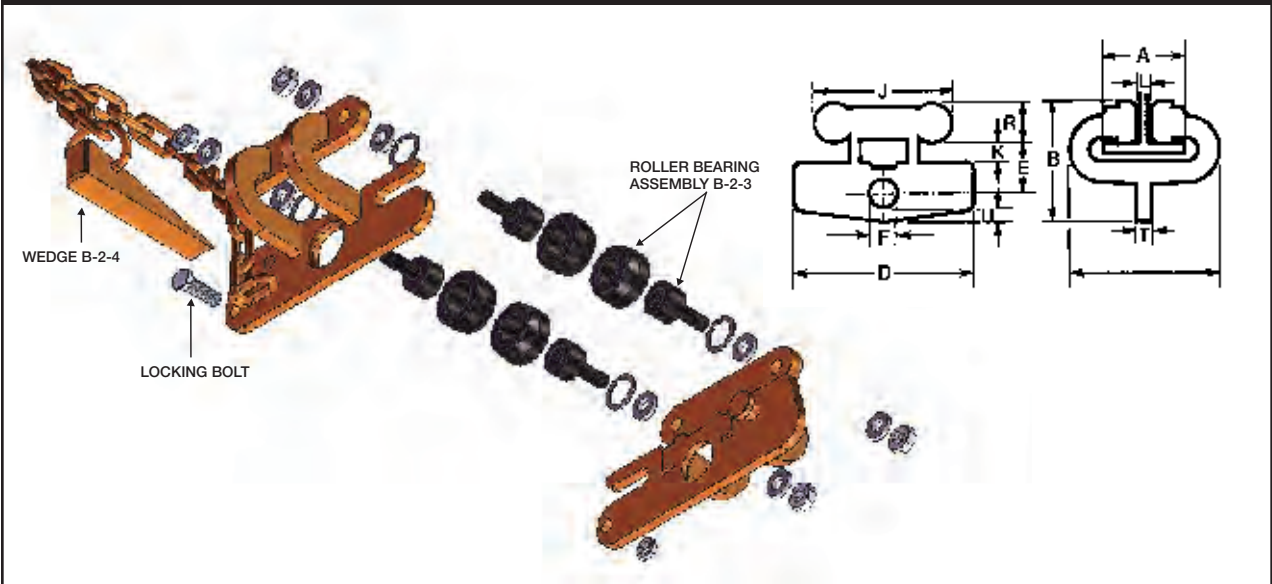

**SPECIFICATIONS** (in inches)

Rated Capacity Tons	Flange Width A	B	C	D	E	F	J	K	L	Weight			U (in pounds)
										R	T		
<b>1</b>	1½-4	5¾	7¼	8¾	2 <sup>9</sup> / <sub>16</sub>	1½	6¾	7/8	5/8	2	¾	¾	18
	2-6	7 <sup>5</sup> / <sub>8</sub>	10½	8¾	3 <sup>3</sup> / <sub>8</sub>	1½	8¾	1¼	1½	3½	¾	¾	28
	4-12	8 <sup>3</sup> / <sub>16</sub>	18	8¾	3 <sup>15</sup> / <sub>16</sub>	1½	8¾	1 <sup>13</sup> / <sub>16</sub>	1 <sup>3</sup> / <sub>8</sub>	3½	¾	¾	38
<b>3</b>	4-6	10¼	12¼	11¼	4	2¼	12¼	1¼	1½	5½	¾	7/8	65
	4-12	10 <sup>7</sup> / <sub>8</sub>	19	11¼	4 <sup>5</sup> / <sub>8</sub>	2¼	12¼	1 <sup>7</sup> / <sub>8</sub>	1½	5½	¾	7/8	78
<b>5</b>	4-8	13 <sup>7</sup> / <sub>16</sub>	16½	16½	5	3 <sup>1</sup> / <sub>8</sub>	15½	1 <sup>7</sup> / <sub>8</sub>	1½	6	1	1	92
	4-14	13 <sup>7</sup> / <sub>16</sub>	22½	16½	5	3 <sup>1</sup> / <sub>8</sub>	15½	1 <sup>7</sup> / <sub>8</sub>	1½	6	1	1	130
<b>8</b>	6-12	18 <sup>1</sup> / <sub>16</sub>	21 <sup>1</sup> / <sub>8</sub>	18 <sup>5</sup> / <sub>8</sub>	6½	3½ x 4 <sup>5</sup> / <sub>8</sub>	21	2½	1½	8	1	1 <sup>7</sup> / <sub>16</sub>	256
	6-17	18 <sup>1</sup> / <sub>16</sub>	27	18 <sup>5</sup> / <sub>8</sub>	6½	3½ x 4 <sup>5</sup> / <sub>8</sub>	21	2½	1½	8	1	1 <sup>7</sup> / <sub>16</sub>	332
	6-24	18 <sup>1</sup> / <sub>16</sub>	35	18 <sup>5</sup> / <sub>8</sub>	6½	3½ x 4 <sup>5</sup> / <sub>8</sub>	21	2½	1½	8	1	1 <sup>7</sup> / <sub>16</sub>	355
<b>12</b>	6-12	18 <sup>1</sup> / <sub>16</sub>	22½	18 <sup>5</sup> / <sub>8</sub>	6½	3½ x 4 <sup>5</sup> / <sub>8</sub>	21	2½	1½	8	1¼	1 <sup>7</sup> / <sub>16</sub>	275
	6-17	18 <sup>1</sup> / <sub>16</sub>	28½	18 <sup>5</sup> / <sub>8</sub>	6½	3½ x 4 <sup>5</sup> / <sub>8</sub>	21	2½	1½	8	1¼	1 <sup>7</sup> / <sub>16</sub>	295
	6-24	18 <sup>1</sup> / <sub>16</sub>	36½	18 <sup>5</sup> / <sub>8</sub>	6½	3½ x 4 <sup>5</sup> / <sub>8</sub>	21	2½	1½	8	1¼	1 <sup>7</sup> / <sub>16</sub>	345

SPECIFICATIONS ARE SUBJECT TO CHANGE WITHOUT NOTICE.



# Model BC

## Locking Type

The **Model BC** is a multi-purpose beam clamp suitable for both lifting beams or providing suspension of hoists from beams or girders, thereby eliminating the need for nuts, bolts and shackles. It is intended for use on the American standard or wide flange beams.



**OPTION:** Now available with soft jaw inserts. Factory installed at time of order or as a Retrofit Kit for customer installation

### MODEL BC EXPLODED VIEW

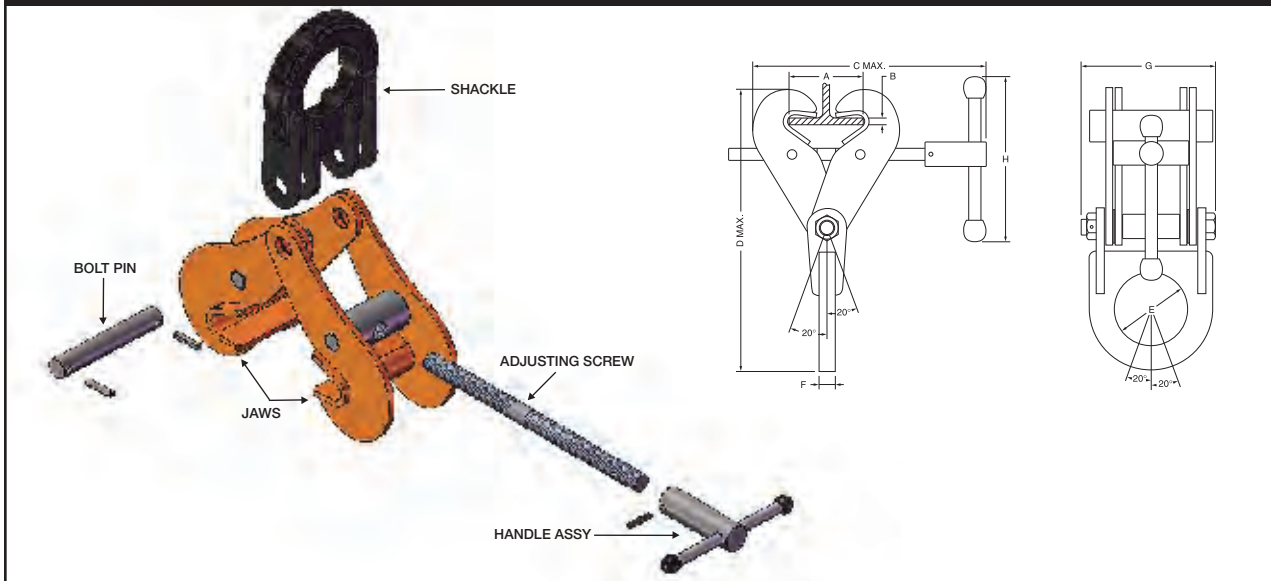

**SPECIFICATIONS** (in inches)

Working Load Limit at 0° - 20° Vertical Tons	Flange Width A	Flange Thickness B	C	D	E	F	G	H	Weight (in pounds)
<b>1½</b>	3 - 7 1/4	1/4 - 1/2	1 17/8	11 3/4	3	1/2	5	5 3/4	9 1/2
<b>3</b>	3 - 7 1/4	1/4 - 1/2	1 17/8	12	3	5/8	5 3/16	6 3/4	13 1/2
<b>5</b>	6 - 9 1/2	1/2 - 3/4	17	14 7/8	3 1/4	3/4	6 5/16	6 3/4	22 1/2
<b>10</b>	6 - 11 1/8	1/2 - 1 1/4	21 1/4	19 1/8	4	1 1/2	7 1/8	9	53
<b>15</b>	8 - 16 3/4	7/8 - 2	32	26 1/2	4 1/2	1 3/4	8 3/8	12	120
<b>25</b>	18 - 38	2 - 3	61	40 1/2	5	2	15	15	450

SPECIFICATIONS ARE SUBJECT TO CHANGE WITHOUT NOTICE.

# Model PB

## Locking Type



The **Model PB** is similar to the Model B-1 and provides quick attachment to beams and girders and may be used in the general rigging of chain falls and hoists. The clamp hinges in two sections allowing quick installation. This model is furnished with a fluted tool steel locking wedge which holds the clamp in place on a beam. The two eyes allow the clamp to be attached in the vertical or horizontal positions. The clamp is of single unit construction and fits a wide range of flange widths.

### MODEL PB EXPLODED VIEW

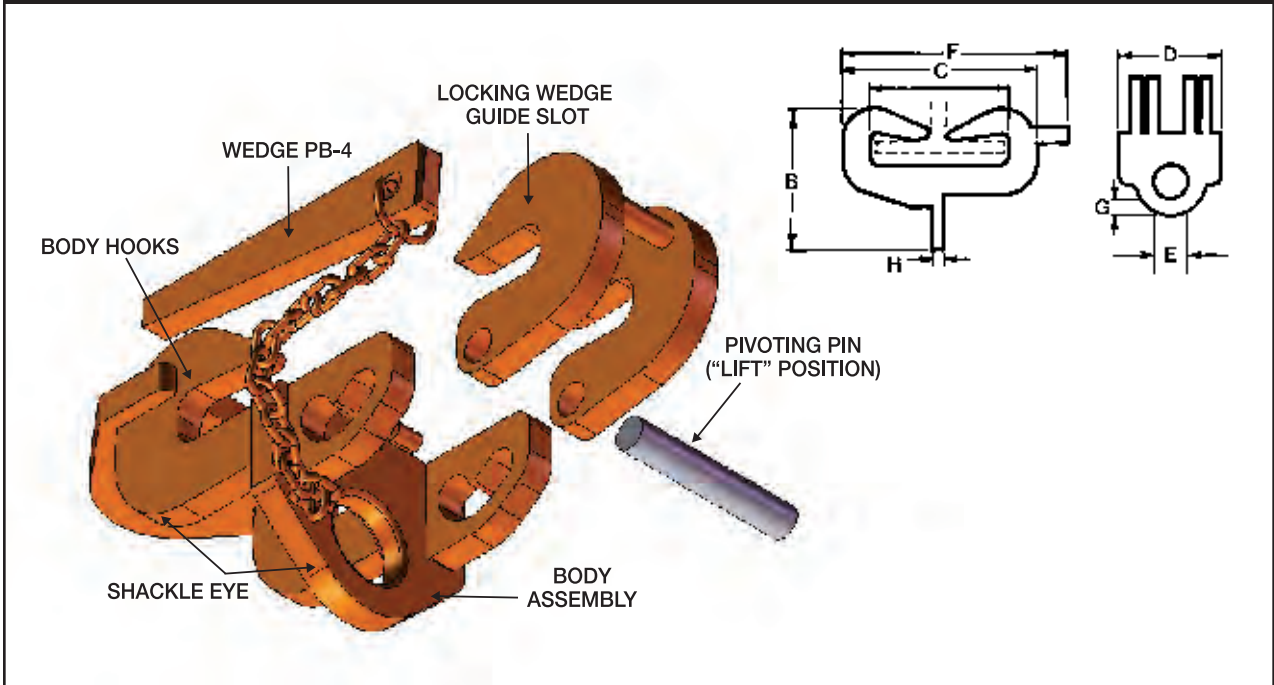

**SPECIFICATIONS** (in inches)

Rated Capacity Tons	Flange Width A	B	C	D	E	F	Weight G	H	(in pounds)
1	2-6	7	7½	5	1½	10⅞	¾	½	10
3	2-6	9½	10½	6½	2¼	13⅙	⅞	¾	28
5	4-8	10½	13	7	2½	15¼	1	¾	44

SPECIFICATIONS ARE SUBJECT TO CHANGE WITHOUT NOTICE.

# PULL





# Model PC

## Locking, Screw Type



Eliminate expensive pad eyes with the **Model PC...** a light "pull clamp" used for pulling and aligning structural members and fabricated sections in the construction and maintenance for shipbuilding and other industries. These clamps are versatile and have a wide range jaw opening. They are secured to the load by tightening the screw and have a rotating cam jaw grip on the screw and clamp body.

### MODEL PC EXPLODED VIEW

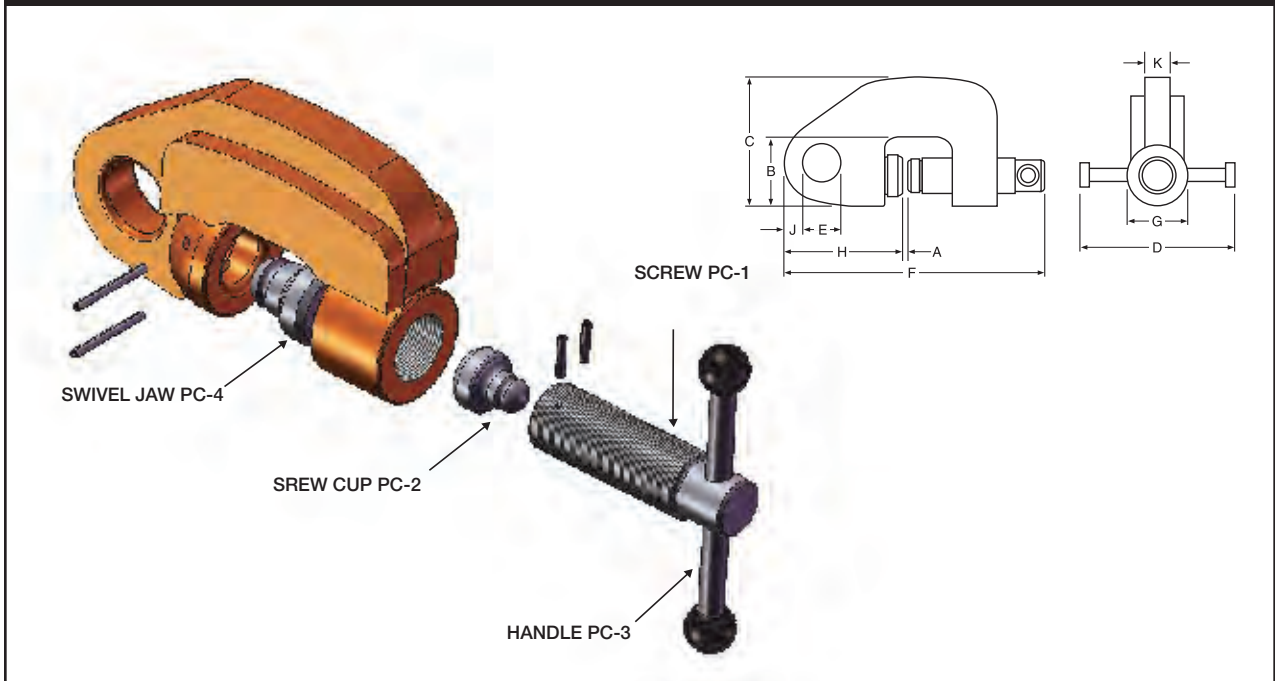

**SPECIFICATIONS** (in inches)

Rated Capacity Tons	Plate Thickness A	B	C	D	E	MAX. F	G	H	J	K	Weight (in pounds)
1	0-1	2½	4 <sup>9</sup> / <sub>16</sub>	5	1¼	9 <sup>1</sup> / <sub>8</sub>	2½	3 <sup>15</sup> / <sub>16</sub>	<sup>5</sup> / <sub>8</sub>	<sup>3</sup> / <sub>4</sub>	10
2	0-1¼	2 <sup>11</sup> / <sub>16</sub>	5	6	1½	11 <sup>1</sup> / <sub>8</sub>	2 <sup>3</sup> / <sub>8</sub>	4 <sup>9</sup> / <sub>16</sub>	<sup>3</sup> / <sub>4</sub>	1	15
3	0-1½	2 <sup>7</sup> / <sub>8</sub>	5¼	6	1¾	12 <sup>5</sup> / <sub>16</sub>	2 <sup>5</sup> / <sub>8</sub>	5 <sup>7</sup> / <sub>16</sub>	<sup>15</sup> / <sub>16</sub>	1	18
5	0-1¾	3¼	5 <sup>7</sup> / <sub>8</sub>	6½	2	13½	2 <sup>7</sup> / <sub>8</sub>	5¾	<sup>15</sup> / <sub>16</sub>	1¼	24

SPECIFICATIONS ARE SUBJECT TO CHANGE WITHOUT NOTICE.

# NON-MARRING



# Model NM

## Locking, Screw Type



The **Model NM** clamp (non-marring) is manufactured with smooth gripping surfaces to prevent marring when gripping stainless steel, copper, aluminum and other polished metal plates. Due to the variety of conditions that may exist in handling these plates, it is recommended that these clamps be used in pairs and attached to a chain or wire rope sling, supported by a spreader beam. The **Model NM** is supplied with stainless steel gripping surfaces and is available with steel or bronze upon request. The **model NM** is not intended for use in transportation of plates using mobile equipment where shocking of the load may occur.

### MODEL NM EXPLODED VIEW

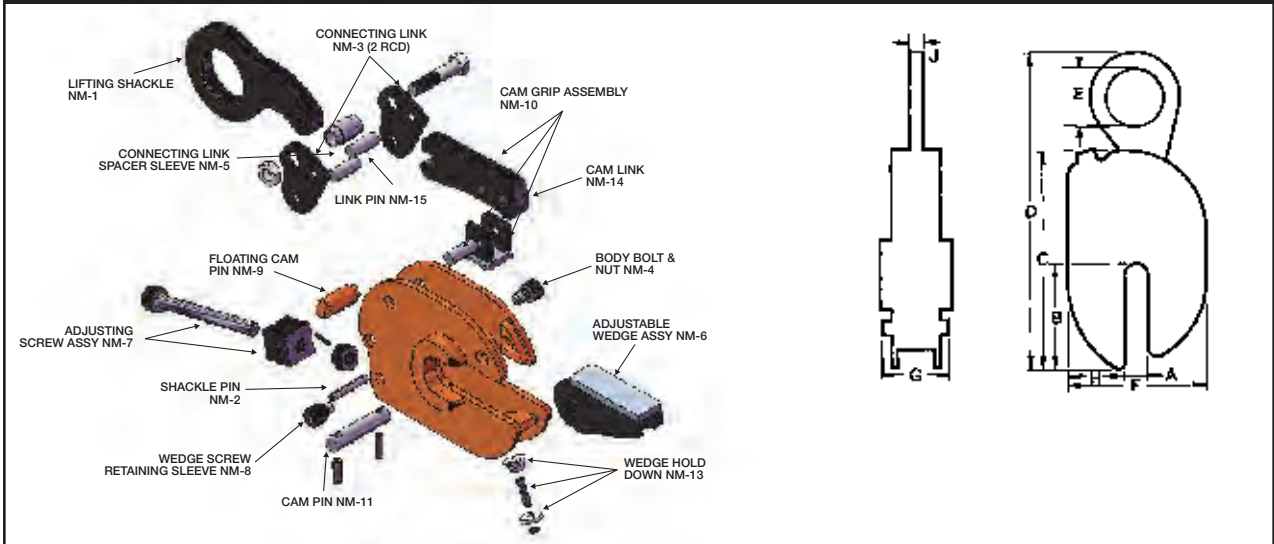

#### SPECIFICATIONS (in inches)

Rated Capacity Tons	Plate Thickness A	B	C	MAX. D	E	F	G	H	J	Weight (in pounds)
1	0-3/4	4 1/2	9 5/8	15 3/8	2 5/8	5 1/2	3 1/8	2 5/8	5/8	17
	3/4-1 1/4	4 1/2	9 5/8	15 3/8	2 5/8	6 1/8	3 1/8	2 5/8	5/8	19
	1 1/4-1 3/4	4 1/2	9 5/8	15 3/8	2 5/8	6 3/4	3 1/8	2 5/8	5/8	21
	1 3/4-2 1/4	4 1/2	9 5/8	15 3/8	2 5/8	7 1/8	3 1/8	2 5/8	5/8	23
2	0-1	5 1/8	10 1/16	16	2 5/8	6 3/4	3 3/4	2 7/8	5/8	23
	3/4-1 1/2	5 1/8	10 1/16	16	2 5/8	7 1/4	3 3/4	2 7/8	5/8	27
	1 1/4-2	5 1/8	10 1/16	16	2 5/8	7 3/4	3 3/4	2 7/8	5/8	28
	1 3/4-2 1/2	5 1/8	10 1/16	16	2 5/8	8 1/4	3 3/4	2 7/8	5/8	30
	2 1/4-3	5 1/8	10 1/16	16	2 5/8	8 3/4	3 3/4	2 7/8	5/8	33
4	1/4-1 1/2	5 5/8	12 1/2	18 9/16	2 15/16	7 3/4	4 1/2	2 15/16	1	45
	1 1/4-2 1/2	5 5/8	12 1/2	18 9/16	2 15/16	8 1/4	4 1/2	2 15/16	1	48
	1 3/4-3	5 5/8	12 1/2	18 9/16	2 15/16	9 1/4	4 1/2	2 15/16	1	50
	3-4 1/4	5 5/8	12 1/2	18 9/16	2 15/16	11	4 1/2	2 15/16	1	55
8	1 1/2-3 1/4	11	20 1/4	27 3/4	3 3/8	15 3/8	6 3/8	5 5/8	2	193
	1 3/4-3 1/2	11	20 1/4	27 3/4	3 3/8	15 3/8	6 3/8	5 5/8	2	195
	3-4 1/2	11	20 1/4	27 3/4	3 3/8	16 1/8	6 3/8	5 5/8	2	210
	4-5 1/2	11	20 1/4	27 3/4	3 3/8	17 1/8	6 3/8	5 5/8	2	225
12	2-4	11	20 1/4	27 3/4	3 3/8	16 1/2	7 1/8	5 5/8	2	200
	3 3/4-5 1/2	11	20 1/4	27 3/4	3 3/8	17 3/8	7 1/8	5 5/8	2	220
	4 1/2-6	11	20 1/4	27 3/4	3 3/8	18 1/8	7 1/8	5 5/8	2	240

SPECIFICATIONS ARE SUBJECT TO CHANGE WITHOUT NOTICE



# Model NMA

## Locking Type

The **Model NMA** is a non-marring clamp with smooth gripping pads that can lift hard surface materials. Materials with sensitive finishes such as stainless steel, copper, aluminum and polished metal plates can also be lifted. The clamp incorporates a locking feature which enables the clamps gripping jaws to be “Locked Open” for attaching and removing the clamp from the material being lifted and to be “Locked Closed” for turning material through 180 degrees. It is recommended these clamps be used in pairs.

### MODEL NMA EXPLODED VIEW

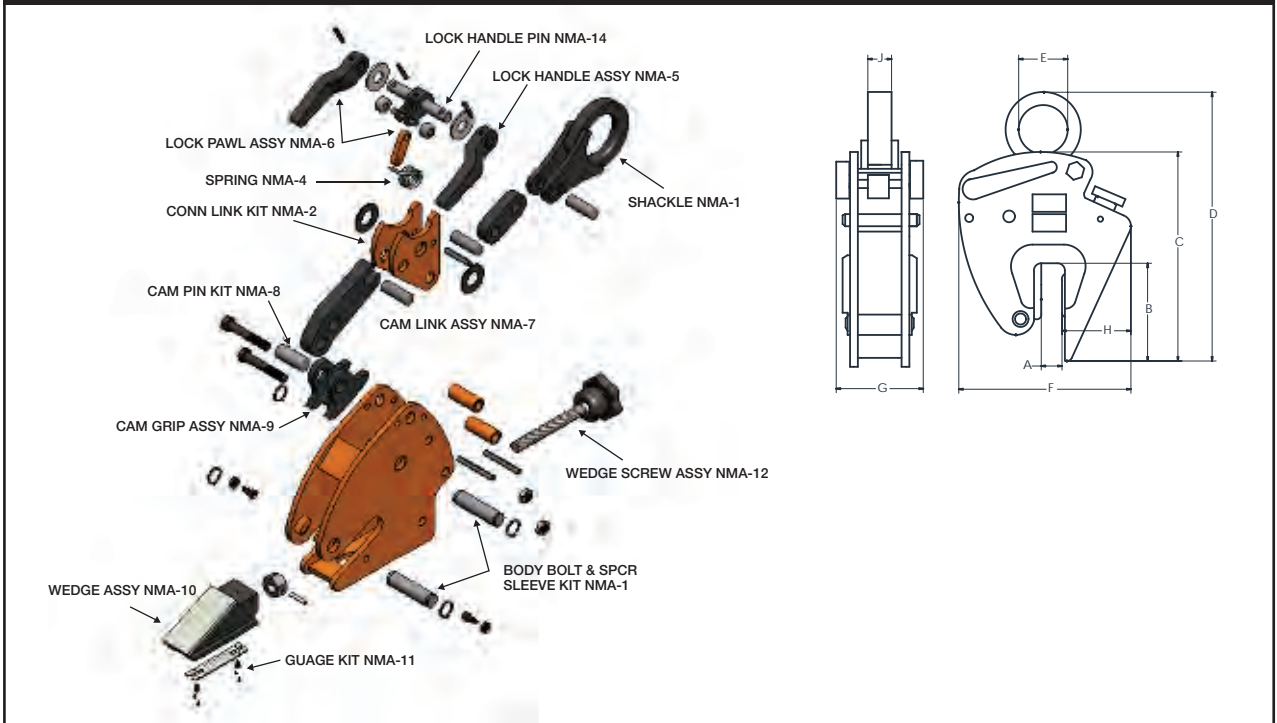

**SPECIFICATIONS** (in inches)

Rated Capacity Tons	Plate Thickness A	B	C	D	E	MAX. F	G	H	J	Weight (in pounds)
1/2	0 - 1/2	3 7/16	7 26/32	12 1/16	2	7 1/4	4 1/4	2 15/16	1/2	16
1	0 - 3/4	4 3/4	11 3/8	16 13/16	2 5/8	9 5/8	5 1/16	4 5/8	5/8	27
2	0 - 1	5 1/2	12 7/8	20 1/8	3	11 1/2	6	4 15/32	3/4	53
4	1/4 - 1 1/4	6 31/32	14 7/16	22 1/4	3 5/8	11 11/16	6	4 7/8	1	63 1/2
4	1 - 2	6 31/32	14 7/16	22 1/4	3 5/8	12 13/16	6	4 7/8	1	65 1/2

\*larger capacities available on request. SPECIFICATIONS SUBJECT TO CHANGE.



# Model NMBL Locking Type



The **NMBL** model is used to turn plates from the horizontal through a 180 degree arc. It is manufactured with smooth gripping surfaces to prevent marring when gripping stainless steel, copper, aluminum and other polished metal plates. The NMBL incorporates a lock open – lock closed feature to facilitate attaching and removing the clamp from the plate.

## MODEL NMBL EXPLODED VIEW

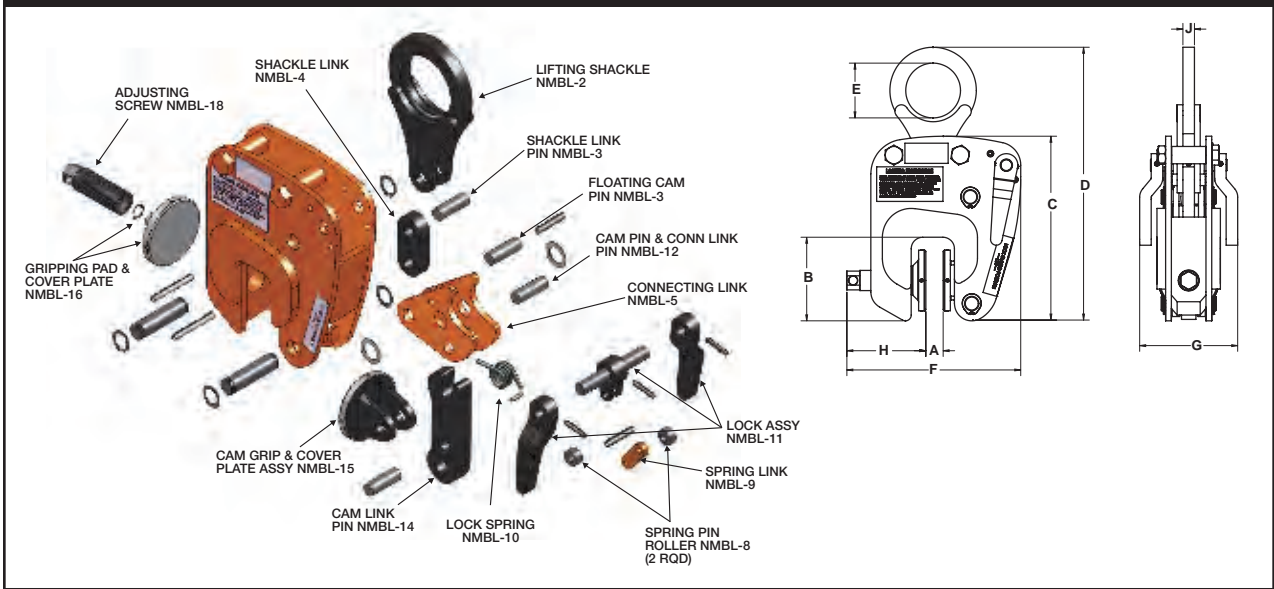

**SPECIFICATIONS** (in inches)

Rated Capacity Tons	Plate Thickness A	B	C	D	E	MAX. F	G	H	J	Weight (in pounds)
1/2	0-5/8	3 5/8	8	12 5/16	2 3/8	7 5/8	4 1/4	3 7/16	1/2	15 5/8
1	0-3/4	3 5/8	8	11 7/8	2 3/8	7 9/16	4 1/4	3 7/16	1/2	17 1/4
2	0-2	4 7/8	10 7/8	17 9/16	3	12 1/32	5 1/2	5 7/16	3/4	31
4	1/4-1 1/2	7 11/64	16 3/16	23 25/32	3	6 1/4	8 1/2	8 9/64	1 1/4	126

SPECIFICATIONS ARE SUBJECT TO CHANGE WITHOUT NOTICE



# Model NMRSC

## Locking, Screw Type

The **Model NMRSC** is a lightweight screw clamp for bench work on steel plates of large thickness, and weighing less than 1000 lbs. Supplied with smooth gripping surfaces to prevent marring when gripping stainless steel, copper, aluminum and other polished metal plates.

### MODEL NMRSC EXPLODED VIEW

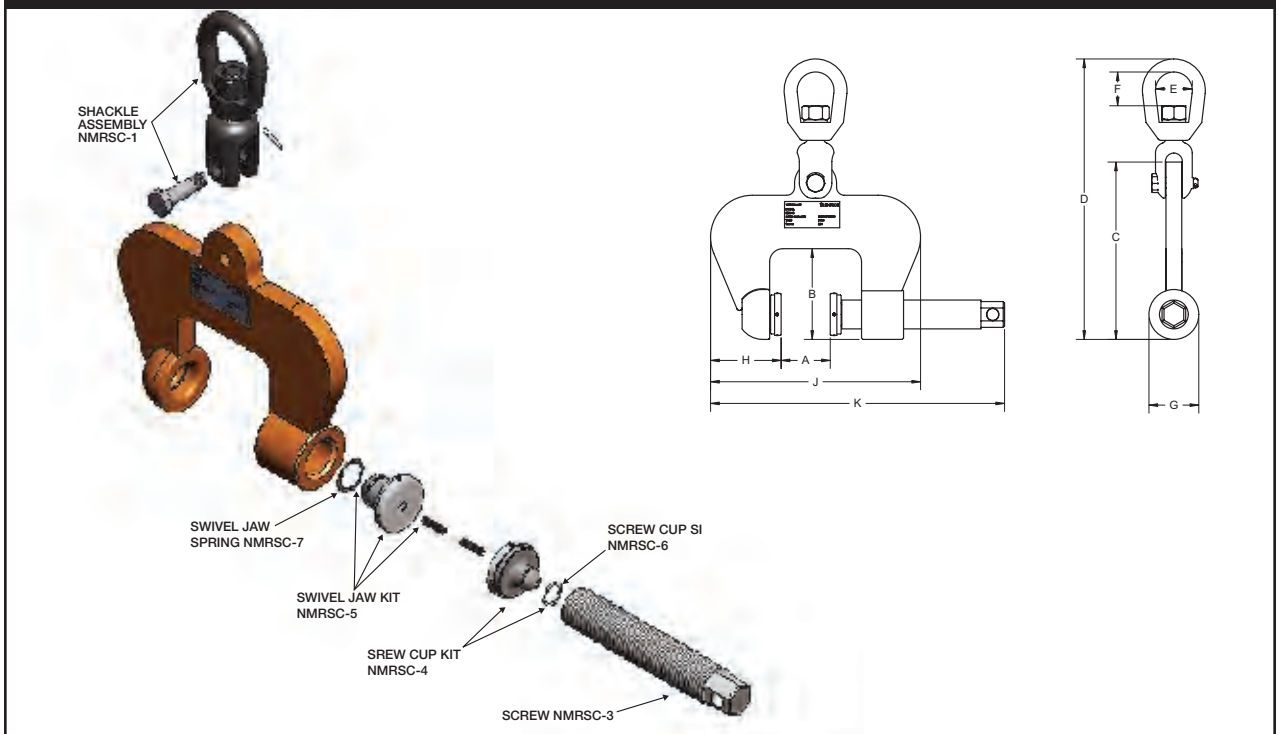

**SPECIFICATIONS** (in inches)

Rated Capacity Tons	Plate Thickness A	B	C	D	E	F	G	H	Weight J	K	(in pounds)
1/2	0-3	4 <sup>5</sup> / <sub>16</sub>	8 <sup>1</sup> / <sub>16</sub>	13 <sup>3</sup> / <sub>8</sub>	1 <sup>1</sup> / <sub>4</sub>	1 <sup>9</sup> / <sub>16</sub>	2 <sup>3</sup> / <sub>8</sub>	3 <sup>3</sup> / <sub>8</sub>	10	14	13 <sup>7</sup> / <sub>8</sub>
1/2	1 <sup>3</sup> / <sub>8</sub> -4 <sup>1</sup> / <sub>4</sub>	4 <sup>5</sup> / <sub>16</sub>	8 <sup>1</sup> / <sub>16</sub>	13 <sup>3</sup> / <sub>8</sub>	1 <sup>1</sup> / <sub>4</sub>	1 <sup>9</sup> / <sub>16</sub>	2 <sup>3</sup> / <sub>8</sub>	3 <sup>3</sup> / <sub>8</sub>	11 <sup>3</sup> / <sub>16</sub>	15 <sup>15</sup> / <sub>16</sub>	14 <sup>1</sup> / <sub>2</sub>

SPECIFICATIONS ARE SUBJECT TO CHANGE WITHOUT NOTICE.

# New Solutions For New Challenges...

# RENFROE



Versatile

Non-Marring

Soft Jaw

## FREE SAFETY TRAINING

Increase the level of your employee's expertise in application, inspection and maintenance of clamps. Call Joe Pless at 1-800-874-8454. For your nearest distributor, call **1-800-874-8454.**

 **RENFROE**

IT'LL TAKE A LOAD OFF YOUR MIND

Made in USA



# DRUM LIFTERS – VERTICAL ONLY





# Model 300-S Locking Type

The **Model 300-S** is used for vertical lifting and transporting of metal drums. Equipped with a past center locking device which secures the clamp tightly to the drum. The **Model 300-S** is capable of handling one drum at a time.



## MODEL 300-S EXPLODED VIEW

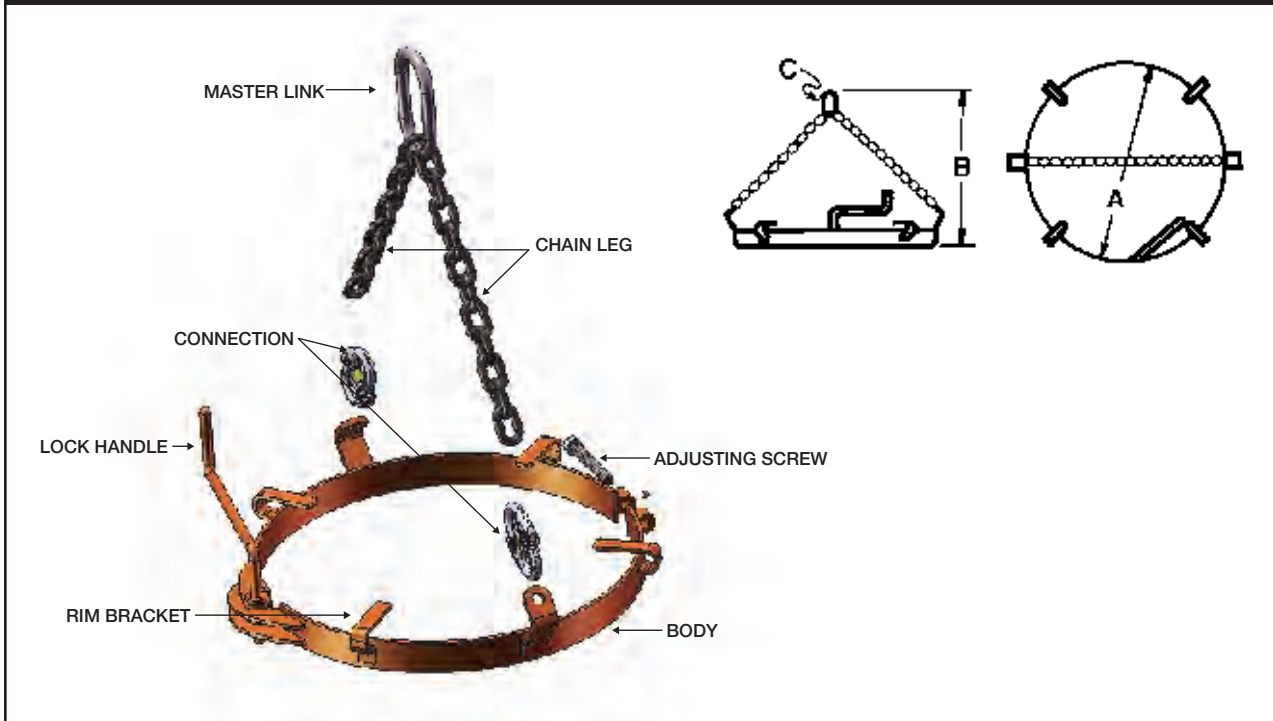

**SPECIFICATIONS** (in inches)

MODEL	Rated Capacity (in pounds)	Drum Diameter	Standard B	Standard C	Weight (in pounds)
300-S	3,000 lbs.	22½	25	3 x 6	25
300-S	3,000 lbs.	18½	25	3 x 6	24
300-S	3,000 lbs.	16½	25	3 x 6	23

SPECIFICATIONS ARE SUBJECT TO CHANGE WITHOUT NOTICE.



## Model 400-M Locking Type

The **Model 400-M** is used for vertical lifting and transporting of metal drums. Equipped with a past center locking device which secures the clamp tightly to the drum. The **Model 400-M** is capable of handling four drums.

### MODEL 400-M EXPLODED VIEW

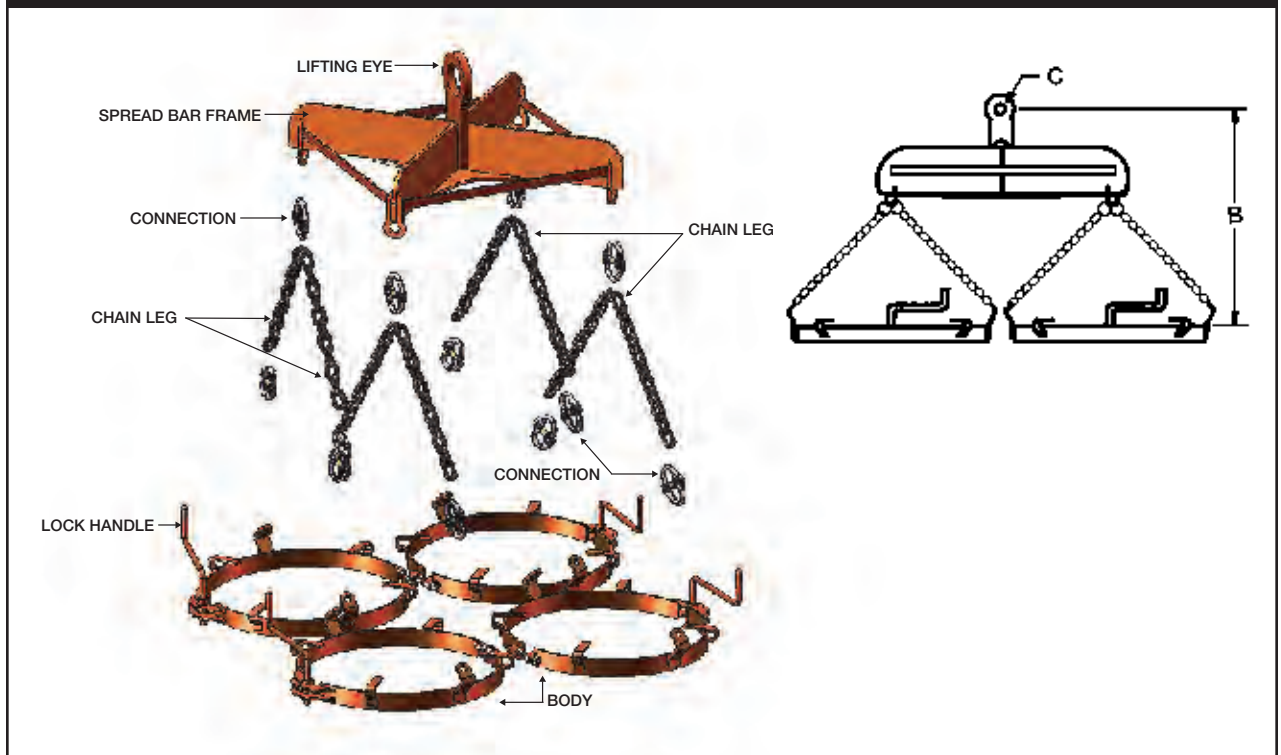

#### SPECIFICATIONS (in inches)

MODEL	Rated Capacity (in pounds)	Drum Diameter	Standard B	Standard C	Weight (in pounds)
400-M	12,000 lbs.	22½	273	¾	275
400-M	12,000 lbs.	18½	25	¾	273
400-M	12,000 lbs.	16½	273	¾	270

SPECIFICATIONS ARE SUBJECT TO CHANGE WITHOUT NOTICE.



# TOOL

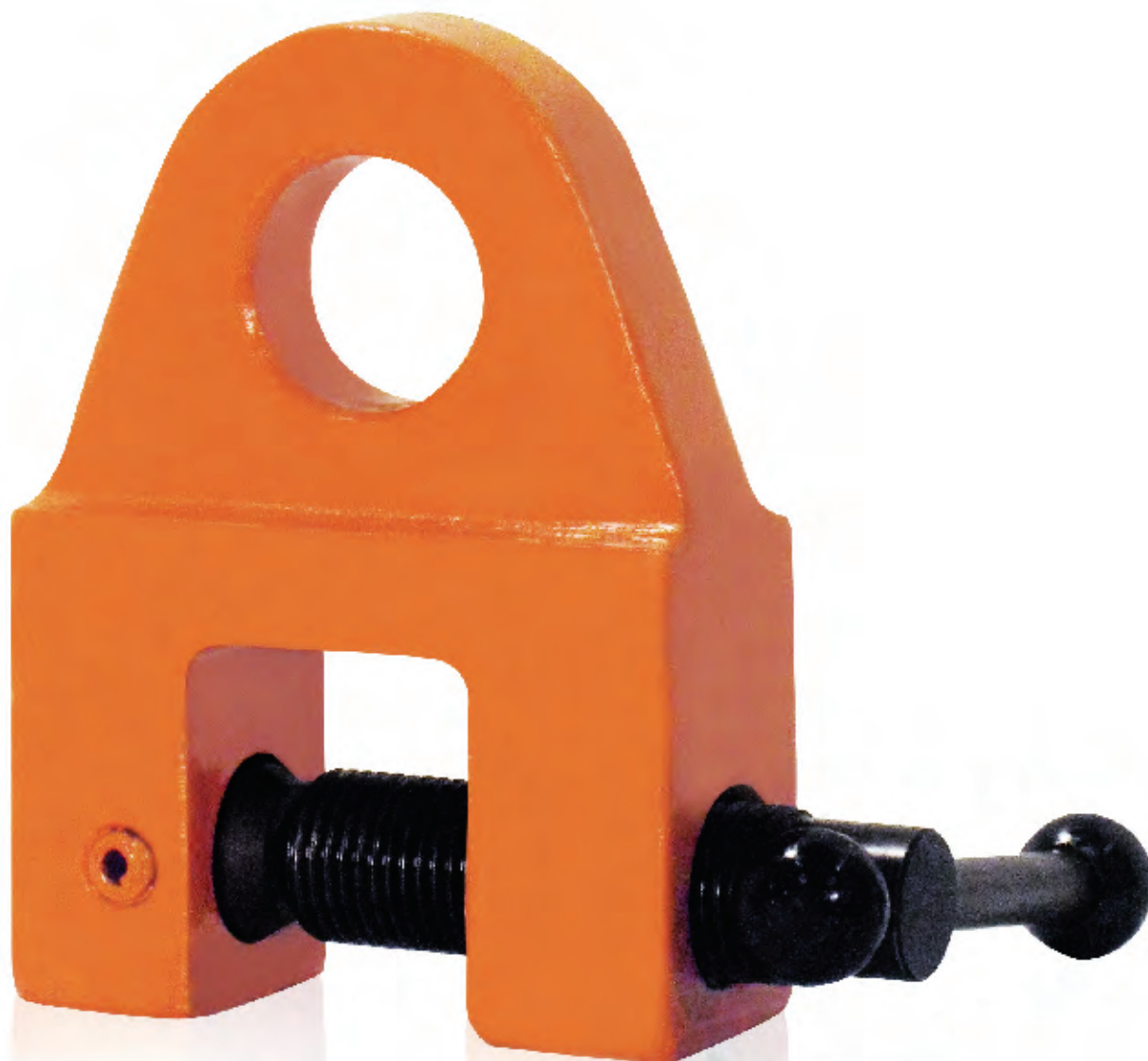

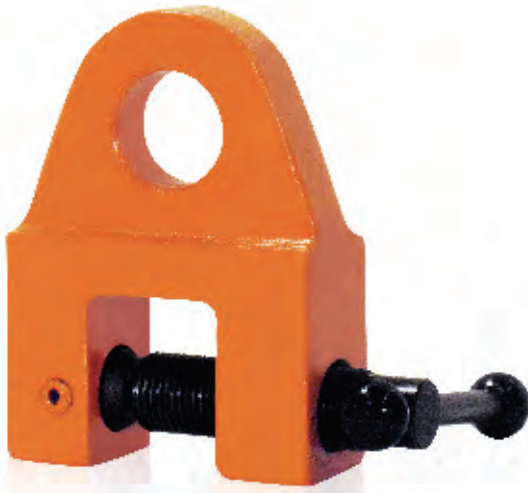

# Tagline Tool

The Tagline is a tool to which a load-guiding lanyard is attached to assist in controlling the swing of a load during transport and to aid in aligning the load before it is brought to rest.

## MODEL TAGLINE EXPLODED VIEW

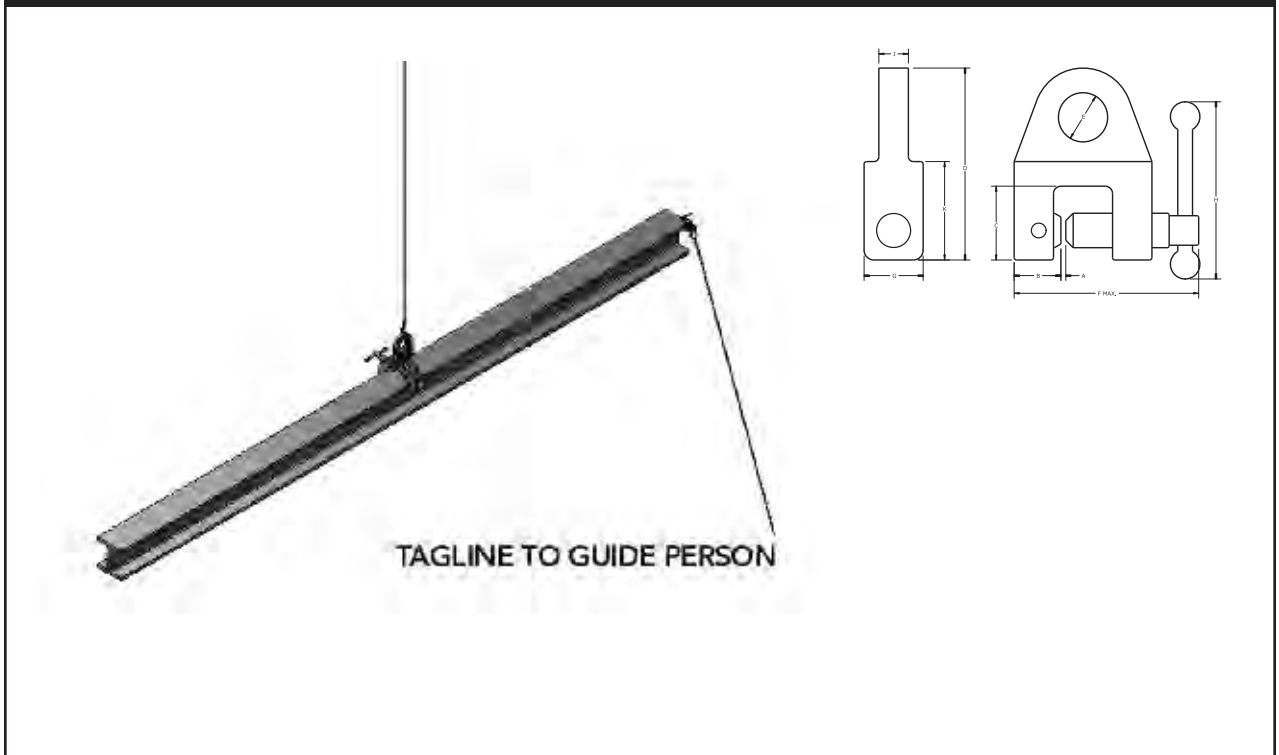

TAGLINE TO GUIDE PERSON

**SPECIFICATIONS** (in inches)

Plate Thickness A	B	C	D	E	MAX. F	G	H	J	K	Weight (in pounds)
0-1	1 -3/16	1 7/8	4 7/8	1 1/4	5 9/16	1 1/2	4 1/2	3/4	2 1/2	4
1-2	1 -5/16	2 1/8	5 1/2	1 1/4	6 13/16	1 1/2	4 1/2	3/4	3	5

SPECIFICATIONS ARE SUBJECT TO CHANGE WITHOUT NOTICE.



# Pry Bar Tool



With this amazing simple tool you can prepare plates in stacks easily, quickly and carefully for clamp attachment. The function of the bar includes...

- 1 The exact guidance of both bars sliding into each other to ensure a safe application at the point of contact.
- 2 Through a few powerful blows of the double bar handle, the wedge is pushed between the metal plates.
- 3 When the bar is extended, leverage makes it possible to lift even heavy plates to cover the length of the wedge.
4. In this position lifting equipment like Renfroe clamps can easily be applied for lifting

## MODEL PRY BAR EXPLODED VIEW

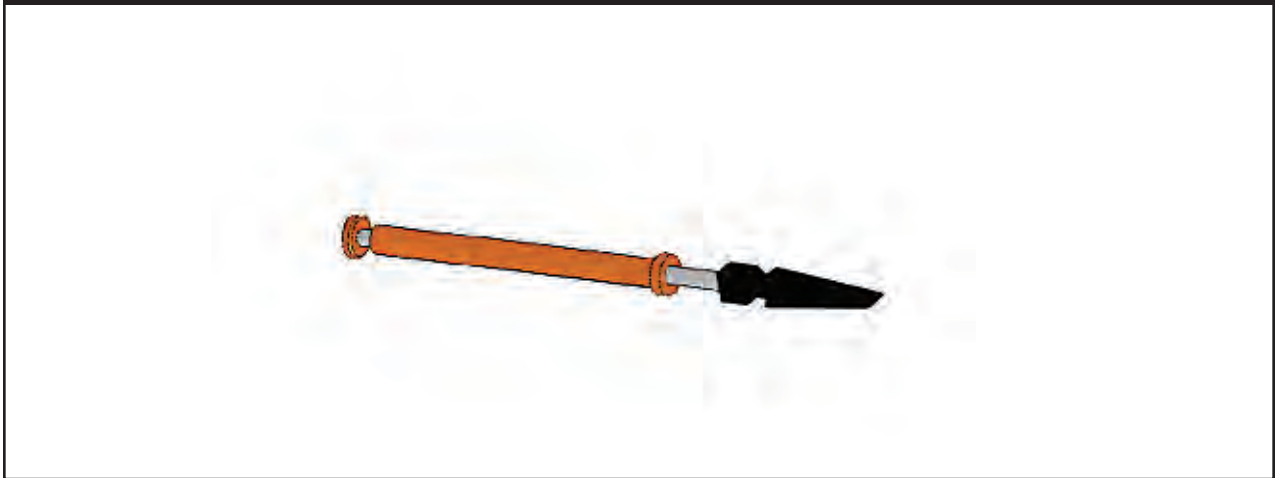

**SPECIFICATIONS** (in inches)

Length Retracted (inches/mm)	Length Extended (inches/mm)	Weight (lbs/kg)
34.625 / 879	51.625 / 1311	14.73 / 6.7
SPECIFICATIONS ARE SUBJECT TO CHANGE WITHOUT NOTICE.		

# Factory Refurbish and Recertification of **Renfro** Clamp's



**ASME B30.20** recommends specific inspections of “Below the Hook” Lifting devices.

**ASME B30.20 Section 20-1.3** lists inspection classifications for inspection, testing and maintenance of structural and mechanical lifting devices.

Replacement parts and Renfro Rebuild Kits are available for customer's to refurbish their Renfro clamps. If, however, you are not comfortable with performing this service for your customer, then J. C. Renfro and Sons can provide this service.

A simple phone call to our customer service department will start the process. We will issue an RGA number to send the clamp(s) to us. Once received, we will inspect it/them and issue a quote for services required to put the clamp(s) into “as new” condition. If requested, we will provide a certificate of proof test.

# SAFETY OPERATING AIDS ( DO's and DON'TS )

- 1 **DO** read and understand the operator's manual before using clamp.
- 2 **DO** consult Operators Manual or RENFROE when in doubt.
- 3 **DON'T** lift over workmen. **DON'T** lift over safety areas or personnel.
- 4 **DO** attend a factory training class for establishing proper use of Renfro Products.
- 5 **DO** Lock clamp closed when clamps are fitted with a lock. **DON'T** lift with lock in open or "lock open" position.
- 6 **DON'T** use a connection that may release the clamp.
- 7 **DON'T** attach clamp directly to crane hook. **DO** use a flexible connection between crane hook and clamp shackle. **DON'T** use heavy flexible connection.
- 8 **DO** use correct clamp for job. **DON'T** use large capacity clamps to lift light loads.
- 9 **DO** use an adequate number of clamps to balance load. **DON'T** lift loads that are not balanced.
- 10 **DO** use clamps within their rated capacity. **DON'T** overload clamps.
- 11 **DO** inspect clamp before each lift, follow inspection and maintenance instructions outlined in the manual and use RENFROE replacement parts to assure proper operation of the clamp.
- 12 **DON'T** use clamp that has been overloaded. **DO** refer to pre-lift inspection in Operator's Manual.
- 13 **DON'T** side load with a straight shackle clamp.
- 14 **DON'T** misuse. **DON'T** lift plate from bottom of plate stack.
- 15 **DON'T** rush. **DON'T** lift more than one plate at a time with a vertical clamp.
- 16 **DON'T** improvise. Always use correct clamp for the job. **DON'T** lift plate horizontally with a vertical lift only clamp.
- 17 **DON'T** alter clamp. **DON'T** grind, weld or modify the clamp in any manner.



## NOTICE OF EXCLUSION OF WARRANTY

RENFROE HAS HEREIN SET FORTH IN CONSPICUOUS LANGUAGE AN EXCLUSION OF ANY WARRANTY EITHER EXPRESSED OR IMPLIED, WHICH IS NOT SPECIFICALLY AND PARTICULARLY CONTAINED HEREIN. PLEASE REFER TO THAT STATEMENT FOR REPRESENTATIONS AND WARRANTIES OF PRODUCTS MANUFACTURED BY J.C. RENFROE & SONS.



# DEFINITIONS

**VERTICAL LIFT:** The lifting of a single plate or member in which the lifting force exerted by the rigging is directly above and in line with the lifting shackle as shown in the illustration below.

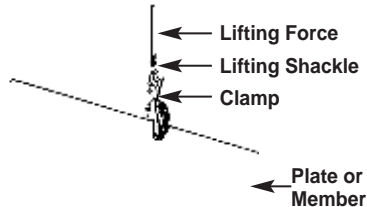

**VERTICAL TURN/LIFT:** A vertical turn/lift clamp is a vertical lifting clamp specifically intended to turn a single plate or member thru a ninety degree (90°) arc and back to vertical thru the same ninety degree (90°) arc or from horizontal to vertical to horizontal thru a one hundred and eighty degree (180°) arc. Refer to Application Section of specific Turn/Lift clamps for further detail.

During the turning operation the edge of the plate opposite the edge to which the clamp is attached should always be in contact with a supporting surface such as a factory floor and the load on the clamp should not exceed one half rated capacity of clamp — refer to illustrations shown below.

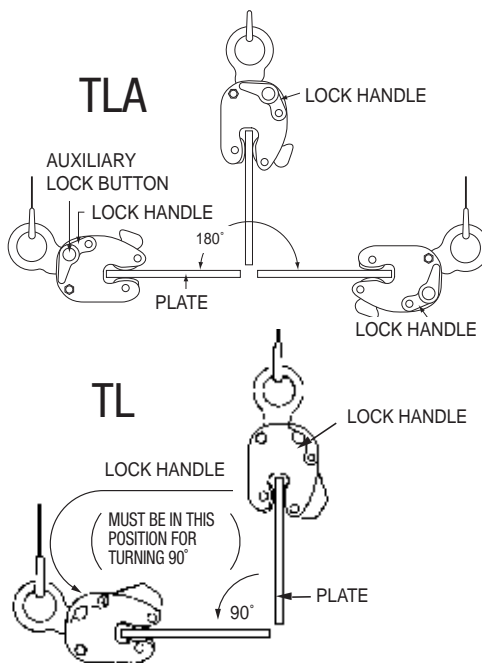

**HORIZONTAL LIFT:** Clamps (used in pairs or multiples) are attached to the side edges of a plate or bundle of plates positioned horizontally to the floor level. The rigging attached to clamps is generally multi-legged slings with the connecting point of the slings being approximately centered between the distance separating the clamps. Refer to illustrations shown below.

**WARNING:** The capacity of all horizontal clamps is based on a sling angle of sixty degrees (60°). See illustration below. Sling angles less than sixty degrees (60°) increase the load exerted on the clamps. Sling angles greater than 60° reduce gripping force, do not exceed 60°.

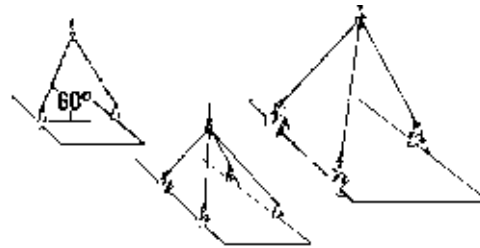

**STEEL PLATES:** Unless otherwise specified, lifting clamps are manufactured to handle hot-rolled steel plates whose Brinell Hardness does not exceed 300.

**WARNING:** Do not lift plates with coatings or mill scale that prevent the gripping surfaces of the clamp from making positive contact with the base metal.

For applications not covered by the above information, secure written recommendations from RENFROE.

**FINISHED AND POLISHED PLATES:**

Steel plates in this category having other than hot-rolled surfaces such as stainless steel, etc., are generally handled using non-marring clamps incorporating smooth gripping surfaces.

**WARNING:** For applications using clamps with serrated gripping surfaces on finished or polished plates, secure written recommendations from RENFROE.

**STRUCTURAL MEMBERS —FABRICATED SECTIONS:**

Unless otherwise specified, clamps described as capable of handling structural members and fabricated sections are limited to hot-rolled steel whose Brinell Hardness does not exceed 300.

**WARNING:** For applications not covered by the above information, secure written recommendations from RENFROE.

**RATED CAPACITY: ALL RENFROE CLAMPS ARE RATED INDIVIDUALLY.**

The rated capacity of a RENFROE product is based on the product being in “new or as new” condition and represents the maximum load the product is to be subjected to when utilized in the manner described in this manual. Wear, misuse, abuse and other factors relating to usage may reduce the rated capacity. Shock loading and the factors listed must be taken into consideration when selecting a RENFROE product for a given application.

**PLATE THICKNESS:** The minimum and maximum plate thickness a clamp specified for handling plates is capable of lifting.



# DEFINITIONS

**WARNING: Never use a clamp for lifting a plate where the plate thickness is less than or greater than the minimum and maximum stenciled on the clamp.**

**JAW OPENING:** The minimum and maximum thickness of a member of a clamp specified as having a JAW OPENING is capable of handling.

**WARNING: Never use a clamp on a member whose thickness is less than or greater than the range of jaw opening stenciled on the clamp.**

**OPERATING TEMPERATURES:** Unless specified under the Applications Section of the individual model, the approved operating temperature of RENFROE clamps is from zero degrees Fahrenheit (-18 Celsius) to a maximum of 200 degrees Fahrenheit (+93 degrees Celsius). The minimum and maximum temperatures apply to both ambient and the material being handled by the clamp.

**WARNING: Secure written authorization from RENFROE before using clamps in temperatures other than shown.**

**“HOT LIFTS”:** The Model R and S clamps are available in modifications that are capable of making lifts where the temperatures of the member being lifted exceeds 200 degrees Fahrenheit (+93 degrees Celsius). Depending on conditions, a lift may exceed 1000 degrees Fahrenheit (538 degrees Celsius). The exact application and temperatures of the plates to be handled are critical in selecting the proper model.

**WARNING: Secure written instructions from RENFROE for all hot lift applications.**

**LOCKING CLAMPS:** Locking clamps are divided into the categories listed below. With the exception of the “Locking Wedge” and “Locking Screw” type the purpose of the locks are to facilitate the attaching and removing of the clamp from the member being handled.

**“Lock Closed”** — an overcenter spring loaded mechanism in which the spring exerts a force on the gripping cam when the lock handle is moved to the “Lock Closed” position. When the handle is moved to unlocked position, the force exerted by the spring is relaxed and the gripping cam may be retracted by pushing the lifting shackle into the body of clamp. Refer to the Operation Section of specific models of “Lock Closed” clamps for additional details. Typical “Lock Closed” clamps are Models DG, FR, M and HRS.

**“Lock Open Only”** — normally used on “Hot Lift” clamps and consists of a manually operated “Lock Stop Pin” that is inserted when gripping cam of clamp is retracted and removed when clamp is positioned on the plate. Tag line may be used to permit operator to remove pin from a greater distance from clamp. Refer to the Operation Section of specific model of “Lock Open Only” clamps for additional details. Typical “Lock Open Only” clamp is the Model RO.

**“Lock Open-Lock Closed”** — an over-center spring loaded mechanism in which the spring exerts a force on the gripping cam when the lock handle is moved to the “Lock Closed” position. When the handle is moved to the “Lock Open” the gripping cam is maintained in the retracted position for ease in installing the clamp on a plate or member. The Model FRD contains individual “Lock Open” and “Lock Closed” mechanisms that must be operated separately. Refer to the Operation Section of specific models of the “Lock Open-Lock Closed” clamps for additional details. Typical “Lock Open-Lock Closed” clamps are Models FRD, R, S, SD, SEA, SX, TL, TLA and the J-Series.

**“Locking Wedge”** — is a fluted steel wedge that is driven in place with a hammer. The body of the wedge is positioned in a slot in the clamp body with the fluted edges contacting the member to which the clamp is being attached. Refer to Operation Section of specific models of the “Locking Wedge” clamps for additional details. Typical “Locking Wedge” clamps are Models A1, B1, B2 and PB.

**“Locking Screw”** — “Locking Screw” clamps depend on manually adjusting a screw to hold the gripping surface in place for lifting and removing the clamp from member being lifted. Refer to Operation Section of a specific model of “Locking Screw” clamps for additional details. Typical “Locking Screw” clamps are Models AC, ACP, BC, NM, PC, SCP, SCPA and RSC.

**NON-LOCKING:** “Non-Locking” clamps have no mechanisms to aid in attaching or removing clamp from member being lifted. It is necessary to have position of clamp maintained on the member being lifted until a properly applied force is exerted to the lifting shackle. Refer to Operation Section of specific models of the “Non-Locking” clamps for additional details. Typical “Non-Locking” clamps are Models AST, ASTL, BD, HR, HDR, HRS and WHSR.

**WARNING: A POINTING OUT AND NOTICE OF DANGER. THE PURPOSE OF A “WARNING” IS TO APPRISE THE OPERATOR AND ALL OTHER AFFECTED PERSONS OF THE EXISTENCE OF DANGER OF WHICH HE SHOULD BE, BUT MAY NOT BE AWARE; AND TO ENABLE THE OPERATOR TO PROTECT HIMSELF AND OTHERS, WHERE APPLICABLE, AGAINST SUCH DANGER. AN ATTEMPT IS MADE HEREIN TO WARN AGAINST REASONABLE AND REASONABLY FORESEEABLE DANGER IN THE PROPER USE AND POSSIBLE REASONABLE MISUSE OF RENFROE PRODUCTS DESCRIBED IN THIS CATALOG.**

# RENFROE® Operator's Manuals

No operator should engage or attempt to engage in the use of any Renfro product until the applicable manual has been read and fully understood.

**Failure to review and utilize recommended applications, operating and maintenance instructions could result in serious injury to the operator and others.**

An Application, Operation and Maintenance Manual is packaged with each Renfro product. Additional copies are available by contacting J. C. Renfro & Sons at 1-800-874-8454 or by email: sales@jcrenfroe.com.



# RENFROE® Rebuild Kit

## 15% savings when ordering in kits

The construction of RENFROE products permits the installation of repair parts to be accomplished by qualified personnel utilizing recommended procedures for inspection and installation of each product model as recommended in the Maintenance Section of the Operator's Manuals.

When necessary, the worn or damaged parts may be replaced by installing individual replacement parts or through the use of a RENFROE Rebuild Kit which includes all parts generally replaced due to normal wear. Parts not subjected to daily operating wear are not included in the Rebuild Kit and may be purchased separately.

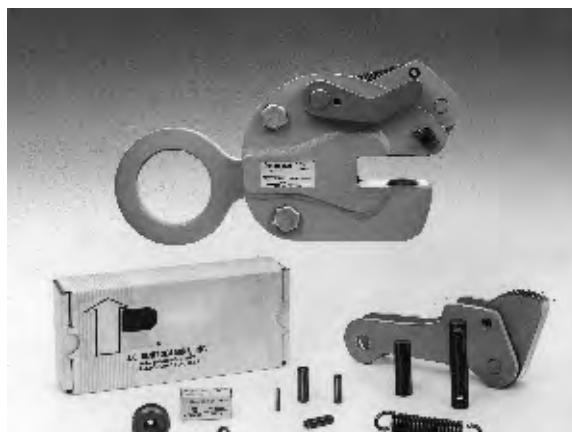

### KITS ARE AVAILABLE FOR THE FOLLOWING MODELS:

- |              |                  |              |              |
|--------------|------------------|--------------|--------------|
| • MODEL AST  | • MODEL FR       | • MODEL RSC  | • MODEL SEA  |
| • MODEL ASTS | • MODEL FRD      | • MODEL S    | • MODEL SX   |
| • MODEL ASTL | • MODEL J SERIES | • MODEL SH   | • MODEL TL   |
| • MODEL BD   | • MODEL LJ       | • MODEL SCP  | • MODEL TLA  |
| • MODEL DC   | • MODEL M        | • MODEL SCPA | • MODEL WHSR |
| • MODEL DG   | • MODEL NM       | • MODEL SCSL | AND HOT      |
| • MODEL DWS  | • MODEL R        | • MODEL SD   | LIFT CLAMPS  |

# GENERAL INFORMATION

**IMPORTANT:** Information contained in this catalog is for the presentation of pertinent illustrative and specification data for use in the selection of suitable RENFROE® products consistent with the use intended by RENFROE. Refer to Operator's Manuals for information on application, operation and maintenance of each particular model or product.

Photographs of products shown in this catalog which may include examples of applications are for illustrative purposes only. Please refer to the Operator's Manuals for approved applications of RENFROE products.

**OPERATOR'S MANUALS: PRIOR TO PURCHASE AND/OR USE OF ANY RENFROE PRODUCT, EACH PURCHASER AND OPERATOR SHOULD READ AND UNDERSTAND FULLY ALL OF THE PERTINENT INSTRUCTIONS AND RECOMMENDATIONS CONTAINED IN THE OPERATOR'S MANUALS FOR THE PARTICULAR PRODUCT INVOLVED.**

**THE OPERATOR'S MANUAL:**

Manuals contain recommended application, operation and maintenance instructions for all RENFROE products listed in this catalog. A copy of the Operator's Manual pertaining to each such product is attached to the product or enclosed within the shipping carton with each product. In addition, Operator's Manuals may be obtained from authorized RENFROE Distributors or by contacting J. C. Renfroe & Sons at 1-800-874-8454 or by email: sales@jcrenfroe.com.

**TRAINING AIDS:** RENFROE provides upon request and at no charge posters, inspection kits containing coded inspection tags, and maintenance inspection record forms.

RENFROE factory representatives are also available upon request to assist with training end-users in the proper use, maintenance, and inspection of RENFROE products. Direct requests to Renfroe Training Department toll free 800-874-8454. Fax 904-354-7865. Email: sales@jcrenfroe.com.

**INSPECTION AND REBUILD:** RENFROE Factory Representatives are available upon request to inspect RENFROE products in use at Plant sites or such other reasonable locations where such products are in use. RENFROE products may be returned to the factory for inspection and rebuild in accordance with an established fee schedule. Neither operators nor maintenance personnel of the user of such products should engage in any modification of any RENFROE product for any reason. Installation of parts and Rebuild Kits should be effected only in accordance with instructions included within the Operator's Manual and as furnished with each RENFROE Rebuild Kit.

**ENGINEERING SERVICE:** Our Engineering Department is ready to assist in the solution of special problems and its service is available at all times to our customers.

**DELAYS:** J. C. RENFROE & SONS is not liable for any delays in manufacturing or shipping caused by fire, strikes, lockouts, war, insurrections, inability to secure materials, government interference or regulations, delays in transportation, or other circumstances beyond reasonable control.

**EXCLUSION OF WARRANTY**  
**THERE EXISTS NO WARRANTIES NEITHER EXPRESSED NOR IMPLIED WHICH EXTEND BEYOND THE DESCRIPTIONS OR STATEMENTS CONTAINED IN THE FACE OR ANY PART HEREOF.**

This catalog supercedes all catalogs previously published by RENFROE and further supercedes any materials previously published or described by RENFROE or its distributors as to the contents hereof.

## Stainless Steel Gripping Surfaces

**KITS ARE AVAILABLE FOR THE FOLLOWING MODELS:**

**Vertical Clamps**

- Model FR
- Model J
- Model JP
- Model JA
- Model JPA
- Model LJ
- Model SCP
- Model SCPA
- Model TL
- Model TLA

**Horizontal Clamps**

- Model HR
- Model HDR
- Model M
- Model WHSR





# THINK OUTSIDE OF THE BLOCK

With Us...

**J.C. Renfroe** offers a full line of quality, dependable bridge and mobile crane blocks.

But what raises Renfroe above the competition is our in-house engineering staff that thinks outside of the box. At Renfroe, we can work with you to develop unique designs and custom specifications to produce blocks for any project. OEM's can work directly with our engineers in the design and manufacture of blocks to accommodate specific applications. Over the past 75 years, we have built our business on customizing products ranging from lifting clamps to sheaves. So, we can "knock off" a block for you, too.

Call 1-800-874-8454 for a free consultation with one of our engineers or for the name of your nearest distributor.



SCAN CODE FOR MORE  
ON RENFROE BLOCKS

**RENFROE**  
IT'LL TAKE A LOAD OFF YOUR MIND

J.C. Renfroe & Sons, Jacksonville, Florida 32206 Toll Free 800.874.8454 • Fax 904.354.7865 • [www.jcrenfroe.com](http://www.jcrenfroe.com)





# Renfroe Sheaves

## Sheave Sizes Available From J.C. Renfroe

**Model “M” (Machined Sheave)** – 3 inches up to 24 inches (Made in USA)

**Available In Imperial And Metric Wire Rope Sizes**

### Renfroe Advantages

- Flexibility in our manufacturing process means we can produce a single sheave without a considerable cost impact.  
Flexibility = Better Lead Time
- Induction groove hardening available.
- Technology, manufacturing flexibility, quality and dependability – all of these features are standard in every J.C. Renfroe product.
- Because of our technology and manufacturing flexibility, we can produce special configurations (dimensions) without the long lead times and without increased costs associated with standard manufacturing techniques.
- Proven technology (worldwide).



# Wire Rope To Sheave Dimensions

Wire Rope Dia.				SHEAVE Outside Diameter (in.)																						
Code	Inches		mm	14	15	16	17	18	20	22	24	26	28	30	32	33	34	36	40	42	48	50	52	55	60	72
06	0.250	1/4	6.5																							
08	0.313	5/16	8																							
09	0.375	3/8	9.5																							
11	0.438	7/16	11																							
13	0.500	1/2	13																							
14	0.563	9/16	14.5																							
16	0.625	5/8	16																							
19	0.750	3/4	19																							
22	0.875	7/8	22																							
26	1.000	1	26																							
29	1.125	1 1/8	29																							
32	1.250	1 1/4	32																							
35	1.375	1 3/8	35																							
38	1.500	1 1/2	38																							

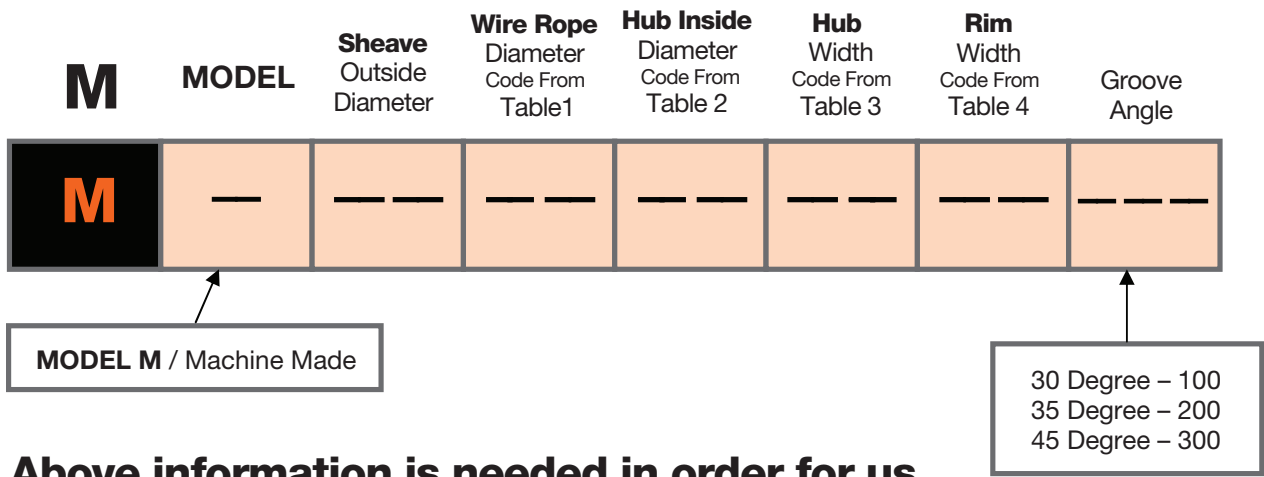

**Above information is needed in order for us to be able to manufacture a sheave for you.**

If Bushings or Bearings are needed, please contact your distributor or the Renfro factory and provide specific information. If you want us to quote and/or provide bearings, you must give us the bearing manufacturer name, and part numbers.

# Wire Rope To Sheave Dimensions

WIRE ROPE Ø		
Code	Inches	Inches
04	0.187	3/16
06	0.250	1/4
08	0.313	5/16
09	0.375	3/8
11	0.438	7/16
13	0.500	1/2
14	0.563	9/16
16	0.625	5/8
19	0.750	3/4
22	0.875	7/8
26	1.000	1
29	1.125	1 1/8
32	1.250	1 1/4
35	1.375	1 3/8
38	1.500	1 1/2

HUB INSIDE DIA.	
Code	Inches
01	0.752
02	0.814
03	0.875
04	1.125
05	1.250
06	1.500
07	1.569
08	1.750
09	1.851
10	1.8745
11	1.876
12	1.880
13	2.000
14	2.060
15	2.0611
16	2.250
17	2.310
18	2.375
19	2.3109
20	2.4995
21	2.500
22	2.560
23	2.5611
24	2.6111
25	2.750
26	2.7505
27	2.9987
28	2.998
29	2.999
30	3.000
31	3.2486
32	3.249
33	3.250
34	3.270
35	3.4985
36	3.499
37	3.500
38	3.548
39	3.672
40	3.7485
41	3.749
42	3.750

HUB INSIDE DIA.	
Code	Inches
43	3.937
44	3.999
45	4.000
46	4.248
47	4.250
48	4.329
49	4.330
50	4.4985
51	4.500
52	4.560
53	4.720
54	4.722
55	4.725
56	4.750
57	4.875
58	5.000
59	5.513
60	5.250
61	5.375
62	5.500
63	5.512
64	5.9984
65	5.9985
66	6.000
67	6.100
68	6.125
69	6.375
70	6.497
71	6.498
72	6.4984
73	6.500



HUB WIDTH	
Code	Inches
01	1.250
02	1.375
03	1.500
04	1.563
05	1.625
06	1.750
07	1.970
08	2.000
09	2.1875
10	2.190
11	2.250
12	2.310
13	2.3125
14	2.375
15	2.500
16	2.750
17	2.810
18	2.875
19	2.880
20	2.9375
21	3.000
22	3.375
23	3.380
24	3.500
25	3.620
26	3.625
27	3.6875
28	3.750
29	3.875
30	4.000
31	4.120
32	4.125
33	4.500
34	5.000
35	5.750
36	2.313

RIM WIDTH CODES	
Number Code	Fraction inches
05	1/2
06	9/16
07	5/8
08	11/16
09	3/4
10	13/16
11	7/8
12	15/16
13	1.0
14	1 1/16
15	1 1/8
16	1 3/16
17	1 1/4
18	1 5/16
19	1 3/8
20	1 7/16
21	1 1/2
22	1 9/16
23	1 5/8
24	1 3/4
25	1 13/16
26	1 7/8
27	2.0
28	2 1/16
29	2 1/8
30	2 5/16
31	2 1/2
32	2 7/16
33	2 1/2
34	2 9/16
35	2 5/8
36	2 3/4
37	2 13/16
38	2 7/8
39	3.0



## DIMENSIONS OF SHEAVES

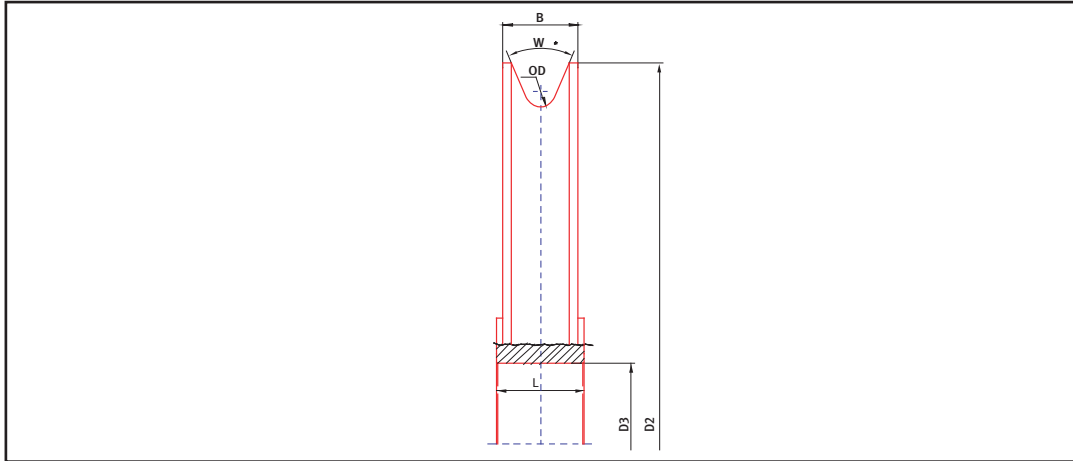

Outside D2 (inches)	Wire Rope Size (inches)	Hub width L (inches)	Rim Width B (inches)	Nom. Hub O.D. (inches)
3	3/16	3/4	3/4	NA
3	1/4	3/4	11/16	1
3	1/4	3/4	3/4	NA
3	5/16	3/4	3/4	NA
3	3/8	3/4	3/4	NA
3	3/8	1	7/8	1-1/2
3	7/16	1	1	NA
3	1/2	1	1	NA
<b>4 inches</b>				
4	3/16	3/4	5/8	2
4	1/4	1	5/8	2
4	5/16	3/4	5/8	2
4	3/8	3/4	3/4	NA
4	3/8	13/16	3/4	2
4	3/8	1	7/8	2
4	3/8	1-1/2	1-3/8	2
4	7/16	1-1/16	1	2
4	1/2	1-1/16	1	2
4	1/2	1-1/2	1-3/8	2
4	5/8	1-1/2	1-3/8	2
<b>6 inches</b>				
6	1/4	7/8	3/4	2-1/2
6	3/8	7/8	3/4	2-1/2
6	3/8	3/4	3/4	NA
6	3/8	1-1/8	1	2-1/2
6	7/16	1-1/8	1	2-1/2
6	1/2	1-1/8	1	2-1/2
6	1/2	1-3/8	1-1/4	2-1/2
6	9/16	1-1/8	1	2-1/2
6	5/8	1-5/16	1-1/4	2-1/2
6	5/8	1-3/8	1-1/4	2-1/2
6	5/8	1-3/4	1-5/8	2-1/2
6	3/4	1-3/4	1-5/8	2-1/2
<b>8 inches</b>				
8	3/8	1-1/8	1	2-3/4
8	7/16	1-3/8	1-1/4	2-3/4
8	1/2	1-1/8	1	2-3/4
8	1/2	1-3/8	1-1/4	2-3/4
8	5/8	1-3/8	1-1/4	2-3/4
8	5/8	1-1/2	1-3/8	2-3/4
8	5/8	1-3/4	1-5/8	2-3/4
8	3/4	2	1-3/4	2-3/4
8	3/4	2-1/4	2-1/8	3
8	7/8	2-1/4	2-1/8	3
<b>10 inches</b>				
10	3/8	1-1/8	1	3-1/4
10	7/16	1-3/8	1-1/4	3-1/4
10	1/2	1-1/8	1	3-1/4
10	1/2	1-3/8	1-1/4	3-1/4
10	1/2	1-5/8	1-1/2	3-1/4
10	9/16	1-3/8	1-1/4	3-1/4

# Standard Sheaves With Dimensions (Machine Made)



Outside D2 (inches)	Wire Rope Size (inches)	Hub width L (inches)	Rim Width B (inches)	Nom. Hub O.D. (inches)
10	5/8	1-3/8	1-1/4	3-1/4
10	5/8	1-5/8	1-1/2	3-1/4
10	5/8	1-3/4	1-5/8	3-1/4
10	3/4	1-5/8	1-1/2	3-1/4
10	3/4	1-3/4	1-5/8	3-1/4
10	7/8	2	1-3/4	4
10	7/8	2-1/2	2-5/16	4
10	1	2-3/8	2-1/4	4
10	1	2-1/2	2-5/16	4
<b>12 inches</b>				
12	3/8	1-1/8	3/4	4
12	7/16	1-3/8	1-1/4	4
12	1/2	1-3/8	1-1/4	4
12	1/2	1-7/8	1-3/4	4
12	9/16	1-3/8	1-1/4	4
12	5/8	1-3/4	1-5/8	4
12	5/8	1-7/8	1-3/4	4
12	3/4	1-3/4	1-5/8	4
12	3/4	2	1-3/4	4
12	7/8	1-3/4	1-5/8	5
12	7/8	2	1-3/4	5
12	7/8	2-3/4	2-1/2	5
12	1	2-1/2	2-5/16	5
12	1	2-3/4	2-1/2	5
<b>14 inches</b>				
14	1/2	1-3/8	1-1/4	5
14	9/16	1-3/8	1-1/4	5
14	5/8	1-5/8	1-1/2	5
14	5/8	1-7/8	1-3/4	5
14	3/4	1-5/8	1-1/2	5
14	3/4	1-7/8	1-3/4	5
14	7/8	2	1-3/4	5
14	7/8	2-3/4	2-1/2	5
14	1	2-3/8	2-1/4	5-1/2
14	1	2-1/2	2-5/16	5-1/2
14	1-1/8	2-1/2	2-5/16	5-1/2
14	1-1/8	2-3/4	2-1/2	5-1/2
<b>16 inches</b>				
16	1/2	2	1-1/4	5
16	9/16	2	1-5/8	5
16	5/8	2	1-3/4	5
16	3/4	2	1-3/4	5
16	7/8	2-1/2	2	5
16	1	2-1/2	2-1/4	6
16	1-1/8	2-3/4	2-1/2	6
<b>18 inches</b>				
18	1/2	2	1-1/4	5
18	9/16	2	1-5/8	5
18	5/8	2	1-3/4	5
18	3/4	2	1-3/4	6
18	7/8	2-1/2	2	6
18	1	2-1/2	2-1/4	6
18	1-1/8	2-3/4	2-1/2	6-1/2
18	1-1/4	3	2-3/4	6-1/2
<b>20 inches</b>				
20	5/8	2	1-3/4	6
20	3/4	2	1-3/4	6
20	7/8	2-1/2	2	6
20	1	2-1/2	2-1/4	6
20	1-1/8	3	2-1/2	6-1/2
20	1-1/4	3	2-3/4	6-1/2
20	1-3/8	3-1/2	2-7/8	8
20	1-1/2	3-1/2	3	8
<b>24 inches</b>				
24	5/8	2	1-3/4	6
24	3/4	2	1-3/4	6
24	7/8	2-1/2	2	6
24	1	2-1/2	2-1/4	6
24	1-1/8	3	2-1/2	6-1/2
24	1-1/4	3	2-3/4	6-1/2
24	1-3/8	3-1/2	2-7/8	8
24	1-1/2	3-1/2	3	8



# Model S Synthetic Sheaves



## **MDS Cast Nylon 6** (Other Materials Available)

### **Features and Benefits**

- Lighter than Steel Sheaves
- Good Rigidity and Hardness
- High Impact Value
- Corrosion Resistant
- Low to No Moisture Absorption
- Good Resistance to Chemicals
- Dimensionally Stable
- Wide Variety of Dimensions Available

### **Applications**

- Overhead Traveling Bridge Cranes
- Mobile Cranes
- Port Cranes
- Offshore Cranes and Platforms
- Conveyor Systems
- And Many More



## Bearing Policy

Please contact the Renfro Plant for spec ordering of bearings.

## Sales Policy

Freight: Freight is F.O.B. shipping point. Freight is prepaid and allowed within the mainland US on orders: With a value greater than \$3,000 net

Return Goods Policy: No material may be returned without prior written permission. Contact customer service for a Return Material Authorization (RMF) Number.

Invoice Terms: Net 30 days after date on invoice. A prompt payment discount of 1% is allowed for invoices paid within 10 days.

Pricing: J.C. Renfro & Sons reserves the right to change prices at any time.

## Definitions

**Commercial Surface Quality** – the surface condition associated with the normal methods of production of raw materials and machined surfaces.

**Design Factor** – a measure of the theoretical reserve capacity, which is determined by dividing the ultimate load by the working load limit.

**Proof Load** – the average force to which a product is subjected before deformation occurs.

**Proof Test** – a test conducted on a product to determine injurious material or manufacturing defects.

**Shock Load** – a force that results from the rapid application of a force or a rapid movement of a static load.

**Static Load** – the load resulting from a constant applied force or load.

**Ultimate Load** – the average load or force at which a product fails or no longer supports the load.

**Working Load** – the maximum mass or force for which the product is authorized to support in a particular service.

**Working Load Limit** (also known as WLL, Rated Load Value and Resultant) – the maximum mass or force for which the product is authorized to support in general service when the pull is applied with respect to the centerpiece of the product.





# Sheave Inquiry & Order Form

<b>A</b>	
OUTSIDE DIAMETER	
<b>B</b>	
ROPE DIAMETER	
<b>C</b>	
SHAFT SIZE	
<b>D</b>	
BUSHING, BEARING, PLAIN BORE	
<b>E</b>	
HUB WIDTH	
<b>F</b>	
HUB DIAMETER	
<b>G</b>	
RIM WIDTH	
<b>H</b>	
QUANTITY	

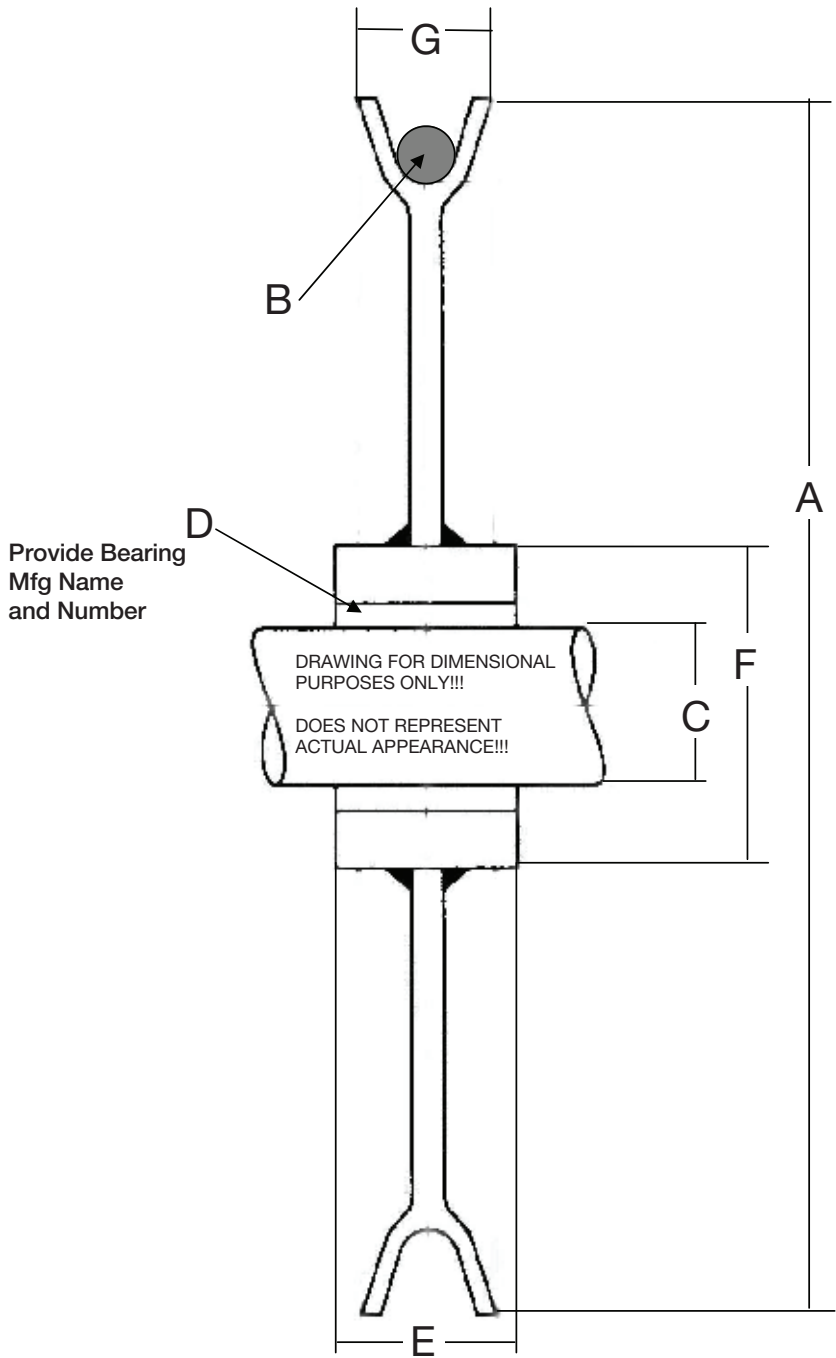

Date: \_\_\_\_\_

Company: \_\_\_\_\_

Contact: \_\_\_\_\_

Phone: \_\_\_\_\_

Fax: \_\_\_\_\_

E-mail: \_\_\_\_\_



1926 SPEARING ST.  
 JACKSONVILLE, FL. 32206  
 PH: 904-356-4181 FAX: 904-354-7865



Be sure to make extra copies for future orders.

## Sheave Inquiry/Order Form

<i>Customer Name</i>		<i>Date</i>	
<i>Address</i>	<i>City</i>	<i>State/Zip</i>	<i>Country</i>
<i>Phone</i>	<i>Fax</i>	<i>E-mail</i>	
<i>Customer Contact Name</i>		<i>Quantity</i>	
<i>P.O. Number</i>		<i>Inquiry Number</i>	

**RENFROE, please quote me on the following Sheave**  
ALL SPACES MUST BE COMPLETED

<b>Step 1</b>	<b>Step 2</b>	<b>Step 3</b>	<b>Step 4</b>	<b>Step 5</b>	<b>Step 6</b>	<b>Step 7</b>	<b>Step 8</b>	<b>Step 9</b>
Sheave O.D.	Wire Line Size	Shaft Size	Bore Type	Bearing Type	Manufacturer Bearing Number	Hub Width	Rim Width	Tread Diameter

**M:** Machined Bore (furnished without bearing or bushing)    **BZ:** Bronze Bushed  
**R:** Roller Bearing    **B:** Ball Bearing  
  
**A:** Assembly (furnished with bearing or bushing)

### Application Information

<i>Line Pull</i>	<i>Fleet Angle</i>	<i>Degree of Wrap</i>
<i>Line Speed</i>	<i>Environment</i>	

### Special Requirements

<i>Special Testing</i>
<i>Finish</i>
<i>Third Party Inspection or Approval</i>

Contact your **RENFROE** Distributor for more information

Copyright © 2004 J. C. Renfroe & Sons  
All Rights Reserved

Contact:

**J.C. RENFROE & SONS**  
Jacksonville, Florida  
Telephone: 904/356-4181  
Toll Free: 800-874-8454  
Fax: 904/354-7865

**COPY & FAX**

# Renfroe Sheaves

## Instructions For Installation, Operations And Maintenance

### General:

These instructions are applicable to wire rope sheaves and hook blocks supplied as complete units, either with bearings or bushings.

### Stocking of delivered parts:

Our customers have to make sure that the parts supplied by our firm are stored in a dry and temperate place.

When wire rope sheaves are stored outside, the bearings or bushings and the spaces in the hubs have to be completely filled with grease in order to prevent the formation of condensed water. The lubrication holes, in case of sealed or shielded bearings have to be closed by grease. In cases of bearings, without seals or shields, please take the necessary precautions, in order to avoid the dirt, the humidity and the other foreign objects between the opened bearings.

The non-machined and primed surfaces should be protected in order to avoid corrosion.

In cases when the wire rope sheaves are already installed in the plant, and if an extended length of time passes between the installation of the assembly and the start of the running, the pulley grooves must be lubricated sufficiently in order to avoid oxidation.

### Installation:

In the case of wire rope sheaves, please check before the installation to assure the diameter of the shaft is in the tolerance range h 6. Then grease the wire rope sheaves making sure that the cavities between the bearings are also completely filled with grease. The grease should be seen exiting the assembly.

Do lubricate the shaft (Mo S2) in order to avoid damage to the shaft and then install the sheave.

If several pulleys are assembled consecutively on the same shaft, make sure that there is separation between the bushings, and the bushings are lubricated.

If it is not required in another way, the greasing of the pulley must be done centrally through the shaft by axial and radial holes of lubrication. For correct lubrication, the gap between the bearings in the sheave must be on the center of the hole for lubrication in the shaft. This pertains to all the wire rope sheaves which are equipped with bearings.

In case of wire rope sheaves with bushings, grease and install. Prior to the start of the running, check if the bushings work with a smooth action.

In the case of sheave assemblies, please take special care in not damaging the seals or shields.

For the model with cylindrical bearings with lip seals SL04 ... PX, the spacer must be designed in such a way that they are situated in front of the seals and they cannot push them when greasing. Please make sure that the suitable installation is assured.

### Concerns for all the wire rope sheaves:

Without calling attention to the type of bearing chosen, re-lubrication of each wire rope sheave must be possible. This is not necessary in the case of bearings with 2 RS seals with charge of permanent grease and if the working conditions permit it.

As general norm, all the bearing assemblies are only preserved, and must be fully lubricated before putting into service.



## Working and maintenance:

The wire rope sheaves with bearings have to be greased again in maximum intervals of 3-6 months (must be determined by user based on their usage). Please make sure that the old grease is completely eliminated from the bearings. Grease until the fresh grease appears. Clean the lube fittings before greasing so that no foreign material enters the bearings.

In case of wire rope sheaves with friction bushings, lubricate at least every four weeks.

## Lubricants:

Use only grease of high quality with base of saponified lithium, suitable for working temperatures from -20 (C) / -4 (F) degrees to more than +100 (C) / 212 (F) degrees.

For working at low temperature, the grease must be of good quality for a range for less than -40 (C) / -40 (F) degrees to more than +100 (C) / 212 (F) degrees.

## Instructions of service and control for cable grooves:

The cable grooves of each sheave must be covered by viscous grease before putting them in service. This condition of greasing must be controlled continuously during the working of the crane. This also implies that all the cables must be greased. In order to protect the cable groove from undue wear, the fleet angle of the cable in working conditions should never exceed 2°.

The movement of the cable must be adjusted in a way that in the start and the end of each operation, any cable sliding, which may cause undue wear of the cables and the cable grooves, should not happen. You must give a good initial tension to the cables in order to avoid the axial and the radial deformation in the cable groove.

The cable grooves must be inspected frequently for wear, (to be determined by user based of severity of service).





**At J.C. Renfroe**

# Our Business is Picking Up

**with mobile crane blocks & bridge crane blocks manufactured in Jacksonville, Florida.**

Utilizing the same technology and quality production we have delivered with our clamp line for over 70 years, J.C. Renfroe is now producing a line of crane blocks in our Jacksonville facility which can give your business a lift.

- Bridge crane blocks available in 1 ton to 500 ton capacities
- Mobile crane blocks available in 1 ton to 1000 ton capacities
- Single and multiple sheave configurations
- Standard single point alloy swiveling hook with latch
- Through-the-shaft sheave bearing lubrication
- Double and quad hooks available

Call **J.C. Renfroe** at **1-800-874-8454** for the name of your nearest distributor.

**RENFROE**

**IT'LL TAKE A LOAD OFF YOUR MIND**

**J.C. Renfroe & Sons, Jacksonville, Florida • Toll Free 800.874.8454 • Fax 904.354.7865 • [www.jcrenfroe.com](http://www.jcrenfroe.com)**

# Bridge Crane Blocks

3 Ton to 50 Ton  
Made in USA



## RENFRO SINGLE SHEAVE BRIDGE CRANE BLOCKS

W.L.L. Tons	Wire Line Size	Sheave O.D. (Inch)	Number Of Sheaves	Hook Throat Opening
3	5/16, 3/8, 7/16, 1/2	8, 10, 12	1	1.57"
5	3/8, 7/16, 1/2, 9/16, 5/8	10, 12, 14	1	1.77"
7.5	1/2, 9/16, 5/8, 3/4	12, 14, 16	1	1.97"
10	1/2, 9/16, 5/8, 3/4, 7/8	14, 16	1	2.2"
15	5/8, 3/4, 7/8, 1	14, 16, 18	1	2.48"

## RENFRO TWO SHEAVE BRIDGE CRANE BLOCKS

W.L.L. Tons	Wire Line Size	Sheave O.D. (Inch)	Number Of Sheaves	Hook Throat Opening	Center Of Groove To Center Of Groove Options
5	1/4, 5/16, 3/8, 7/16, 1/2	8, 10, 12	2	1.77"	4.5, 5.0, 5.5, 6.0, 6.5
7.5	3/8, 7/16, 1/2, 9/16, 5/8	10, 12, 14	2	1.97"	5.25, 5.75, 6.0, 6.25, 6.5, 7.0, 7.5, 8.0
10	1/2, 9/16, 5/8, 3/4	12, 14, 16	2	2.2"	6.0, 7.0, 7.5, 8.0, 8.5, 9.5, 10.0
15	1/2, 9/16, 5/8, 3/4	12, 14, 16	2	2.48"	7.5, 8.0, 8.5, 9.0, 10.0, 10.5, 11.0
20	1/2, 9/16, 5/8, 3/4, 7/8	14, 16, 18, 20	2	2.79"	7.5, 8.5, 10.0, 11.0
25	9/16, 5/8, 3/4, 7/8	14, 16, 18, 20	2	3.15"	8.0, 9.0, 10.5, 11.0
30	5/8, 3/4, 7/8, 1	16, 18, 20	2	3.54"	9.0, 10.5, 12.5

# DIN Hook

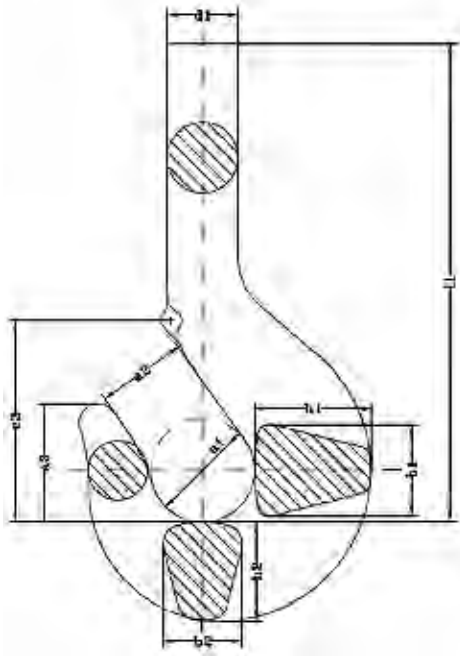

## DIMENSIONS (mm).

HOOK N°	A1	A2	B1	B2	D1	H1	H2	L1	Approx. WEIGHT (Kg.)
0.8	48	38	35	29	30	44	37	186	2.3
1.6	56	45	45	38	36	56	48	224	4.5
2.5	63	50	53	45	42	67	58	253	6.3
4	71	56	63	53	48	80	67	285	10 - 12.3
5	80	63	71	60	53	90	75	318	17 - 19.5
6	90	71	80	67	60	100	85	395	24.5 - 28.5
8	100	80	90	75	67	112	95	430	31.5 - 36
10	112	90	100	85	75	125	106	460	40 - 43
12	125	100	112	95	85	140	118	525	55 - 68
16	140	112	125	106	95	160	132	595	77 - 95
20	160	125	140	118	106	180	150	665	112
25	180	140	160	132	118	200	170	735	160
32	200	160	180	150	132	224	190	810	220
50	250	200	224	190	170	280	236	990	430
63	280	224	250	212	190	315	265	1.120	600
80	315	250	280	236	212	355	300	1.270	860
100	355	280	315	265	236	400	355	1.415	1.220
125	400	315	355	300	265	450	375	1.590	1.740
160	450	355	400	335	300	500	425	1.790	2.480
200	500	400	450	375	335	560	475	2.048	3.420
250	560	450	500	425	375	630	530	2.305	4.800

**STRENGTH CLASS - MATERIALS :** P-T-V - acc. to DIN 15400

**SHANK LENGTH :** l1 = DIN ; in case of l1 > DIN :contact please



# Mobile Crane Blocks

Available up to 1000 Ton capacity  
3 Ton to 50 Ton Made in USA



## MOBILE CRANE BLOCK DATA

SHEAVE DIA. (inches)	Number of Sheaves	Hook Throat Opening (inches)	DIN Hook Number	Approx. Overall Length (inches)	Approx. Thickness (inches)
<b>3 TON</b>					
8	1	1.57	1	26	6
10	1	1.57	1	28	6
12	1	1.57	1	30	6
14	1	1.57	1	32	6
8	2	1.57	1	26	9
10	2	1.57	1	28	9
12	2	1.57	1	30	9
14	2	1.57	1	32	9
<b>5 TON</b>					
10	1	1.77	1.6	31	6
12	1	1.77	1.6	33	6
14	1	1.77	1.6	35	6
16	1	1.77	1.6	37	6
10	2	1.77	1.6	31	9
12	2	1.77	1.6	33	9
14	2	1.77	1.6	35	9
16	2	1.77	1.6	37	9
10	3	1.77	1.6	31	12
12	3	1.77	1.6	33	12
14	3	1.77	1.6	35	12
16	3	1.77	1.6	37	12



# Mobile Crane Block Data

<b>SHEAVE DIA. (inches)</b>	<b>Number of Sheaves</b>	<b>Hook Throat Opening (inches)</b>	<b>DIN Hook Number</b>	<b>Approx. Overall Length (inches)</b>	<b>Approx. Thickness (inches)</b>
<b>7.5 TON</b>					
12	1	1.97	2.5	33	6
14	1	1.97	2.5	35	6
16	1	1.97	2.5	37	6
18	1	1.97	2.5	39	6
12	2	1.97	2.5	33	9
14	2	1.97	2.5	35	9
16	2	1.97	2.5	37	9
18	2	1.97	2.5	39	9
12	3	1.97	2.5	33	12
14	3	1.97	2.5	35	12
16	3	1.97	2.5	37	12
18	3	1.97	2.5	39	12
<b>10 TON</b>					
12	1	2.2	4	33	6
14	1	2.2	4	35	6
16	1	2.2	4	37	6
18	1	2.2	4	39	6
12	2	2.2	4	33	9
14	2	2.2	4	35	9
16	2	2.2	4	37	9
18	2	2.2	4	39	9
12	3	2.2	4	33	12
14	3	2.2	4	35	12
16	3	2.2	4	37	12
18	3	2.2	4	39	12
<b>15 TON</b>					
14	1	2.48	5	35	6
16	1	2.48	5	37	6
18	1	2.48	5	39	6
14	2	2.48	5	35	9
16	2	2.48	5	37	9
18	2	2.48	5	39	9
14	3	2.48	5	35	12
16	3	2.48	5	37	12
18	3	2.48	5	39	12
14	4	2.48	5	35	15
16	4	2.48	5	37	15
18	4	2.48	5	39	15
<b>20 TON</b>					
14	1	2.79	6	37	8
16	1	2.79	6	39	8
18	1	2.79	6	43	8
20	1	2.79	6	45	8
14	2	2.79	6	37	11
16	2	2.79	6	40	11
18	2	2.79	6	43	11
20	2	2.79	6	45	11
14	3	2.79	6	37	14
16	3	2.79	6	40	14
18	3	2.79	6	43	14
20	3	2.79	6	45	14
14	4	2.79	6	37	17
16	4	2.79	6	40	17
18	4	2.79	6	43	17
20	4	2.79	6	45	17



<b>SHEAVE DIA. (inches)</b>	<b>Number of Sheaves</b>	<b>Hook Throat Opening (inches)</b>	<b>DIN Hook Number</b>	<b>Approx. Overall Length (inches)</b>	<b>Approx. Thickness (inches)</b>
<b>25 TON</b>					
14	1	3.15	8	37	8
16	1	3.15	8	39	8
18	1	3.15	8	43	8
20	1	3.15	8	46	8
14	2	3.15	8	37	11
16	2	3.15	8	39	11
18	2	3.15	8	43	11
20	2	3.15	8	46	11
14	3	3.15	8	37	14
16	3	3.15	8	39	14
18	3	3.15	8	43	14
20	3	3.15	8	46	14
14	4	3.15	8	37	17
16	4	3.15	8	39	17
18	4	3.15	8	43	17
20	4	3.15	8	46	17
<b>30 TON</b>					
16	1	3.54	10	43	8
18	1	3.54	10	45	8
20	1	3.54	10	47	8
24	1	3.54	10	49	8
16	2	3.54	10	43	11
18	2	3.54	10	45	11
20	2	3.54	10	47	11
24	2	3.54	10	49	11
16	3	3.54	10	43	14
18	3	3.54	10	45	14
20	3	3.54	10	47	14
24	3	3.54	10	49	14
16	4	3.54	10	43	17
18	4	3.54	10	45	17
20	4	3.54	10	47	17
24	4	3.54	10	49	17
<b>35 TON</b>					
18	1	3.9	12	45	8
20	1	3.9	12	47	8
24	1	3.9	12	49	8
16	2	3.9	12	43	11
18	2	3.9	12	45	11
20	2	3.9	12	47	11
24	2	3.9	12	49	11
16	3	3.9	12	43	14
18	3	3.9	12	45	14
20	3	3.9	12	47	14
24	3	3.9	12	49	14
16	4	3.9	12	43	17
18	4	3.9	12	45	17
20	4	3.9	12	47	17
24	4	3.9	12	49	17
16	5	3.9	12	43	20
18	5	3.9	12	45	20
20	5	3.9	12	47	20
24	5	3.9	12	49	20

# Mobile Crane Block Data

SHEAVE DIA. (inches)	Number of Sheaves	Hook Throat Opening (inches)	DIN Hook Number	Approx. Overall Length (inches)	Approx. Thickness (inches)
<b>40 TON</b>					
20	1	3.9	12	53	8
24	1	3.9	12	55	8
18	2	3.9	12	48	11
20	2	3.9	12	50	11
24	2	3.9	12	55	11
16	3	3.9	12	47	14
18	3	3.9	12	48	14
20	3	3.9	12	50	14
24	3	3.9	12	55	14
16	4	3.9	12	47	17
18	4	3.9	12	48	17
20	4	3.9	12	50	17
24	4	3.9	12	55	17
16	5	3.9	12	47	20
18	5	3.9	12	48	20
20	5	3.9	12	50	20
24	5	3.9	12	55	20
<b>45 TON</b>					
24	1	4.4	16	58	9
20	2	4.4	16	50	12
24	2	4.4	16	54	12
18	3	4.4	16	48	15
20	3	4.4	16	50	15
24	3	4.4	16	54	15
16	4	4.4	16	47	18
18	4	4.4	16	49	18
20	4	4.4	16	51	18
24	4	4.4	16	55	18
16	5	4.4	16	47	21
18	5	4.4	16	49	21
20	5	4.4	16	51	21
24	5	4.4	16	55	21
<b>50 TON</b>					
24	1	4.4	16	60	9
24	2	4.4	16	60	12
18	3	4.4	16	53	15
20	3	4.4	16	55	15
24	3	4.4	16	59	15
16	4	4.4	16	50	18
18	4	4.4	16	52	18
20	4	4.4	16	54	18
24	4	4.4	16	60	18
16	5	4.4	16	50	21
18	5	4.4	16	52	21
20	5	4.4	16	54	21
24	5	4.4	16	60	21

Larger Capacities Available to 1000 Ton.

Refer to Hook Dimension Chart.

Available in Various Weights / Block Thickness Increases with Weight.



## Renfro Blocks

The following are the minimum suggested maintenance practices we recommend based upon normal use. Product application, environment and use may dictate a more stringent inspection and maintenance program.

### Inspect for:

1. Wear on pins, axles, rope grooves, side plates, bearings, bushings, and fittings. Excessive wear may be cause to replace parts or remove block from service.
2. Misalignment or wobble in sheaves.
3. Deformation in side plates, pins, axle fitting attachment points. Deformation may be cause to remove block from service.
4. Deformation or corrosion of hook and nut threads.
5. Weld corrosion or weld cracking on welded side plates.
6. Proper fit, deformation and operation of the hook latch.
7. Security of nuts, bolts, and other locking methods, especially after reassembly following a repair or inspection.
8. Deformation and wear of hook.

### Lubrication Schedule:

Lubricate at regular intervals to prevent damage to the bearing. Lubrication intervals are difficult to determine. If plant practice or experience with other applications is not available, consult your lubricant supplier.





Be sure to make extra copies for future orders.

## Block Inquiry/Order Form

<i>Customer Name</i>		<i>Date</i>	
<i>Address</i>	<i>City</i>	<i>State/Zip</i>	<i>Country</i>
<i>Phone</i>	<i>Fax</i>	<i>E-mail</i>	
<i>Customer Contact Name</i>			
<i>P.O. Number</i>		<i>Inquiry Number</i>	

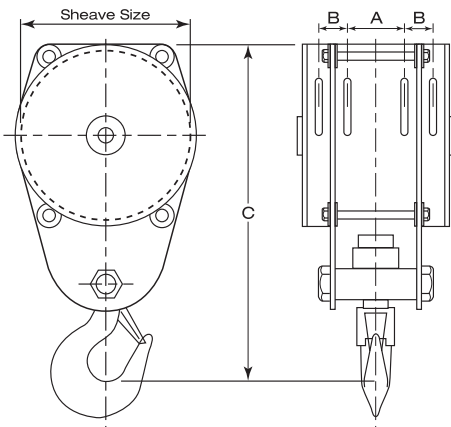

### For Bridge Crane Blocks Specifications Only

<i>Dimensions:</i>	<i>A:</i>	<i>B:</i>	<i>C:</i>
--------------------	-----------	-----------	-----------

### For All Block Specifications

<i>Sheave Diameter</i>	<i>Number of Sheaves</i>
------------------------	--------------------------

### Bearing Type

- Bronze Bushing*
 *Roller Bearing*  
 *Ball Bearing*

### Block Specifications

<i>Working Load Limit</i>	<i>Wire Rope Diameter (Size)</i>
<i>CMMA Rating</i>	

### Lower Fitting Type

- Single Point Hook*
 *Swivel Hook*
 *Other*  
 *Duplex Hook*
 *Latch*

### Application Information

<i>Overhaul Weight Requirements</i>	<i>Lead Line Speed</i>	<i>Environment</i>
-------------------------------------	------------------------	--------------------

### Special Requirements (For Crane Blocks)

<i>Special Testing</i>
<i>Finish</i>
<i>Third Party Inspection or Approval</i>

Copyright © 2004 J. C. Renfro & Sons  
All Rights Reserved

Contact:

**J.C. RENFROE & SONS**  
 Jacksonville, Florida  
**Telephone: 904/356-4181**  
**Toll Free: 800-874-8454**  
**Fax: 904/354-7865**

## COPY & FAX

[www.jcrenfroe.com](http://www.jcrenfroe.com)



**WARNING:**  
**BEFORE PUTTING**  
**TOOL IN SERVICE,**  
**TAKE THE TOOL OR**  
**THIS BOOKLET TO**  
**YOUR IMMEDIATE**  
**SUPERVISOR.**

## Operator's Manual

This Operator's Manual covers the Application, Operation and Maintenance of this RENFRO product. Operator's Manuals for other current RENFRO products are available upon request. Direct requests to J.C. Renfro & Sons, Jacksonville, Florida 32206.

THIS PUBLICATION SUPERSEDES ALL PREVIOUSLY PUBLISHED AND/OR DISTRIBUTED INFORMATION BY MANUFACTURER AND/OR ITS DISTRIBUTORS WITH RESPECT TO APPLICABLE RENFROE PRODUCTS AND SUBJECT MATTER DESCRIBED OR CONTAINED HEREIN.

## **WARNING:**

Prior to selection, operation and/or maintenance of RENFROE products, read and understand the information provided in this manual. The understanding and use of the Definitions are important in determining the limitations and proper application of RENFROE products. Failure to review and utilize recommended

applications, operation and maintenance instructions may result in serious injury, or death to operator and others.

## **NOTICE OF EXCLUSION OF WARRANTY**

RENFROE HAS HEREIN SET FORTH IN CONSPICUOUS LANGUAGE AN EXCLUSION OF ANY WARRANTY EITHER EXPRESSED OR IMPLIED, WHICH IS NOT SPECIFICALLY AND PARTICULARLY CONTAINED HEREIN. PLEASE REFER TO THAT STATEMENT FOR REPRESENTATIONS AND WARRANTIES OF PRODUCTS MANUFACTURED BY J.C. RENFROE & SONS.

# **CRANE BLOCK AND SHEAVE ASSEMBLY WARNING, USE & MAINTENANCE INFORMATION**

## **WARNING**

Failure to use this product properly could result in injury or death. Read, understand and follow these instructions to insure the proper use, selection and maintenance of this product

A crane block system should be rigged by a qualified person as defined by ANSI/ASME B.30.

Instruct workers to keep hands and body away from block sheaves and swivels — and away from "pinch points" where rope touches block parts and or loads.

Use only genuine Renfro parts as replacement.

Read, understand and follow these instructions to select, use and maintain tackle block systems.

When ordering a Renfro product, the ultimate responsibility for selecting the correct product lies with the end user since only the end user has the knowledge of the application and the environment in which the product will be used. Read these instructions carefully and completely.

**NEVER** side load a Renfro product.

The hook latch must **NEVER** support the load. Always make sure the hook supports the load.

Never use the yielding point of the hook as a "gauge" of it's capacity.

**NEVER** weld on any Renfro product.

**NEVER** modify any Renfro product.

Do not immerse standard Renfro products in water.

In the event the stenciling is worn and not legible or the tag containing the model, capacity or other pertinent information is missing, do not use block until it has been properly labeled. Renfro will replace the tag at no charge.



## **MODEL: Bridge Crane Block**

Failure to use this product properly could result in injury or death. Read, understand and follow these instructions to insure the proper use, selection and maintenance of this product.

### **Application**

Renfro crane block systems are used in a wide range of applications, each of which has specifications and technical requirements that are unique to that application. When ordering a Renfro product, the ultimate responsibility for selecting the correct product lies with the end user since only the end user has the knowledge of the application and the environment in which the product will be used. Read these instructions carefully and completely. If you do not understand all words, diagrams, and definitions in this literature contact Renfro for assistance. Ratings shown in Renfro literature are based on the products being in a new and unused condition.

## **Features, Advantages and Benefits of a Renfro Crane Block**

<b>FEATURES</b>	<b>ADVANTAGES</b>	<b>BENEFITS</b>
Forged Alloy Hook	Hook will not break but will straighten-out before failure	Visual sign of overload
Safety Latch	Prevents disconnection from anchor point	Prevents load hook from disconnecting when not under load
Safety Latch	Visual sign of overload	Alerts operator to distortion of the hook
Shaft lubrication fitting	Allows lubrication of sheave bearings without disassembly of crane block	Reduced friction promoting increased sheave bearing life
Selective Sheave and shaft materials	Reliable material quality	Correct material for environmental conditions
Sheave fleet angle	Wide angle of rope lead in	Promotes increased life of rope
Proof tested	Design integrity	Assures operation at WLL



## TERMINOLOGY

**STATIC LOAD** - The load resulting from a constantly applied force or load.

**WORKING LOAD LIMIT** – The maximum force or mass that the product is authorized to support when used within the guidelines of the severity of service rating. The term applies only to static loads held firmly in direct tension. Working Load Limit is used interchangeably with the following terms:

- **WLL**
- **Safe Working Load**
- **SWL**
- **Resultant Safe Working Load**

**WLL of the Crane Block System** – The WLL of a Renfro Block applies only to the block. The WLL of a crane block system can be limited by other parts of the system such as the WLL of the wire rope.

**PROOF LOAD** – The average load to which a product may be subjected before visible deformation occurs.

**PROOF TEST** – A test applied to a product solely to determine the manufacturing integrity of the product.

**SHOCK LOAD** – A significantly increased load factor caused by the sudden shift, jerk or impacting of the load.

**ULTIMATE LOAD** – The average load or force at which the product fails, or no longer supports the load.

**DESIGN FACTOR** – A theoretical reserve capability; usually computed by dividing the ultimate load by the working load limit.

**SHORT TON** – The avoirdupois weight on which Renfro product capacities are based. Commonly used throughout the United States and Canada, the term implies a weight of 2,000 pounds and differs from the “long ton”, which amounts to 2,240 pounds.

**METRIC TON** A unit of mass equal to 2,205 pounds.

**FLEET ANGLE** –The fleet angle is the angle formed between the rope running to or from the extreme left or right of the drum and a line drawn from the center of the sheave normal to the axis of the drum. (See Illustration A next page) For optimum efficiency, the angle here should not exceed 1 1/2 degrees for a smooth drum, or 2 degrees for a grooved drum. If the fleet angle is larger than the recommended limits, it can cause bad winding on smooth drums and rubbing against the flanges of the grooves. Too small a fleet angle should also be avoided since it will cause the rope to pile up against the flange head.

**BLOCK** – A term applied to a wire rope sheave enclosed in side plates and fitted with some attachment such as a hook or shackle.

**SHEAVE** – A grooved pulley for wire rope.

**GROOVES** – Depressions – helical or parallel – in the surface of a sheave or drum that are shaped to position and support the rope.

**TREAD DIAMETER** – The measurement from the deepest point of the sheave groove on one side of the sheave to the deepest point of the sheave groove on the other side (See Illustration B next page)

**PITCH DIAMETER** – A true measurement of the bend of the rope around the sheave

**WIRE ROPE** – A plurality of wire strands helically laid about an axis

**DRUM** – A cylindrical barrel, either of uniform or tapering diameter, on which rope is wound either for operation or storage; its surface may be smooth or grooved.

**HOOK SWIVEL** – The platform from which the hook is housed and suspended from the shaft.

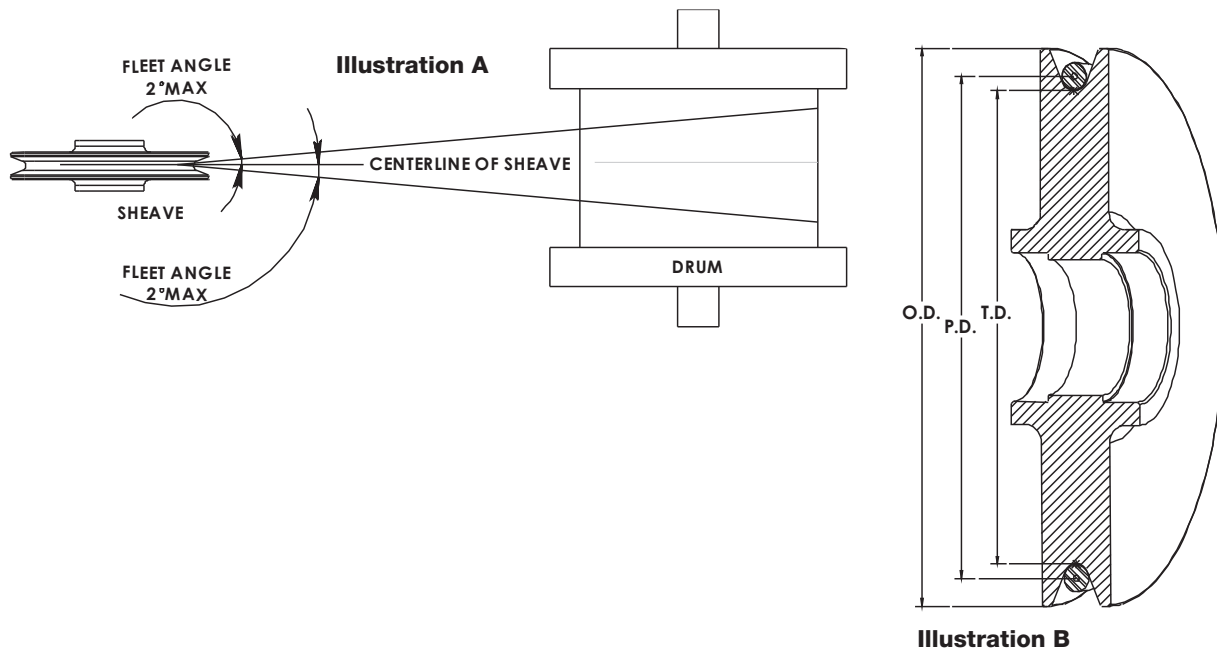

## Sheave Diameter and its Effect on Wire Rope Strength.

When wire rope is bent, its strength is reduced. Refer to the chart to determine the effect of bend radius on wire rope strength when selecting a sheave diameter.

**Ratio A:** Divide Sheave Dia. by Wire Rope Dia. to find Ratio.  
Compare this ratio to the table to determine the strength efficiency of the wire rope.

**Example:**  $10'' \div .50'' = 20 \rightarrow 91\%$  strength efficiency compared to catalog strength.

Ratio A	Strength Efficiency Compared To Catalog Strength In Percentage
40	95
30	93
20	91
15	89
10	86
8	83
6	79
4	75
2	65
1	50

# MAINTENANCE AND INSPECTION

Full and total responsibility for inspection, maintenance and the continued use of the product, lies solely with the owner/user. Product application, environment and manner of use may imply a more thorough inspection and maintenance program is needed. It is the responsibility of the owner/user to assure that all government and industry guidelines are met.

## Inspect for:

- Wear on pins, axles, rope grooves, side plates, bearings, bushings and fittings. Excessive wear is cause to replace parts or remove block from service.
- Deformation in side plates, pins, axle fitting attachment points. Deformation is cause to remove block from service.
- Deformation or corrosion of hook and nut threads.

- Weld corrosion or weld cracking.
- Hook latch for proper fit, deformation and operation.
- Security of nuts, bolts and other locking methods, especially after reassembly following a repair or inspection.
- Check for deformation of hook and for wear.

Any hook or fitting with a crack, gouge or distortion should be removed from service immediately.

## LUBRICATION SCHEDULE:

Lubricate at regular intervals to prevent damage to the bearing.

Lubrication intervals are difficult to determine. If plant practice or experience with other applications is not available, consult your lubricant supplier.

## OPERATION

# INSTRUCTIONS FOR INSTALLATION, WORKING AND MAINTENANCE

## General:

The present instructions are applicable to wire pulleys and blocks supplied as complete units, either with bearings or bushings.

**WORKING LOAD LIMIT – The maximum force or mass that the product is authorized to support when used within the guidelines of the severity of service rating. The term applies only to static loads held firmly in direct tension.**

The working Load Limits of this Renfro product should never be exceeded regardless of the strength of the wire rope being used.

The Working Load Limits apply only to new products shipped from the factory.

Age, type of service and environmental conditions can subsequently affect these limits, and periodic inspections should be performed to assure the product will perform in accord with existing regulations.

## Caution:

Activities such as, but not limited to, pile driving can have adverse effects upon the life of the product.

Inspect your equipment regularly for excessive wear. When using wedge sockets, note that two precautions should be taken.

1. Make sure that a sudden jolt or impact does not dislodge a wedge. When installing wire rope, always pre-load the wedge with wire rope in place. Check frequently to re-tighten or reposition as necessary.
2. Make allowance for the crimping effect common with all types of wedge sockets. Experience shows that it will reduce the Safe Working Limit of a line by 20 percent.



## INSTRUCTIONS FOR SERVICE AND CONTROL OF SHEAVE GROOVES:

The sheave grooves of each sheave must be covered by grease before putting them into service.

This condition of greasing must be controlled continuously during the working of the crane.

This also implies that all the wire ropes must be greased. In order to protect the sheave groove from undue wear, be sure not to allow the fleet angle to exceed 2 degrees.

The working of the wire rope must be fitted in a way that in the start and the end of each operation, any rope sliding which may cause undue wear of the rope and the sheaves does not happen. You must give a good initial tension to the ropes in order to avoid the axial and the radial deformation in the sheave groove.

In case you find excessive wear, the sheave must be replaced by a new one.

In case of sheaves assembled horizontally, there are holes placed in the cover assemblies. These holes must be cleaned every 3 months in order to avoid water collection in the concavity of these sheaves.

 <b>RENFROE</b>	
MODEL	<input type="text"/>
SERIAL No.	<input type="text"/>
WORKING LOAD LIMIT	<input type="text"/> <b>LBS.</b>
CABLE SIZE	<input type="text"/>
SHEAVE DIA.	<input type="text"/>
CLASS	<input type="text"/>
<b>J.C. RENFROE &amp; SONS</b> JACKSONVILLE, FL. 904-356-4181	

## EXCLUSION OF WARRANTY

**THERE EXISTS NO WARRANTIES NEITHER EXPRESSED NOR IMPLIED WHICH EXTEND BEYOND THE DESCRIPTIONS OR STATEMENTS CONTAINED IN THE FACE OR ANY PART HEREOF.**



# The best safety device on the block

Now you can watch your weight with the new weighing hook block that displays to the nearest pound what you're lifting, carrying or weighing. Reassuring? Certainly. Renfroe? Obviously. And you can be assured our weighing blocks feature the same quality, dependability and proof testing as all of our Renfroe products.



- Accuracy is within 0.1% of the actual load weight
- Failure of a load cell doesn't make the load fall
- Large digital display
- Possibility of transmission of weight via radio to a remote display, a computer or to a printer
- Available for any capacity from 1 ton to 300 tons
- No height loss

**RENFROE**  
**WEIGHING HOOK BLOCK**  
IT'LL TAKE A LOAD OFF YOUR MIND

# LOAD WEIGHING & MOTORIZED ROTATION CRANE BLOCKS FOR BRIDGE CRANES



1 SHEAVE STANDARD



2 SHEAVE STANDARD



4 SHEAVE SPECIAL



4 SHEAVE 55 TON



4 SHEAVE STANDARD



4 SHEAVE MOTORIZED



2 SHEAVE SPECIAL

No Display / Shielded  
For Foundry Application

Weight Transmitted via  
Radio Signal to Remote  
Display



6 SHEAVE MOTORIZED  
ROTATION

**Fast, accurate weight readings are essential requirements in order for buyers to be assured they are receiving what they ordered. Shippers can verify they are shipping the correct amount of product to their customers to avoid over or under weight shipments. Also you can control material flow within your facility.**

## Available In Capacities 1 Ton to 300 Ton

The Weighing Block has the same configuration as a conventional Bridge Crane Block, but it incorporates a highly reliable load cell with a precision of +/- 0.1%. It has a digital display 1" (26mm) tall for easy reading at a distance. It can be supplied with a larger display 1 3/4" or 2 3/8" (45mm/ 60 mm) or a larger 5" (130mm) digital display mounted on the crane within a 300 ft. radius.

### Advantages:

- Direct reading of the load weight, avoiding repeated trips to centrally located scales.
- No head room loss. Compact unit.
- Totally independent of crane system.
- Precise load weighing, +/- 0.1% accurate.
- Electronic components are protected.
- A failure of the load cell does not release the load, and does not affect the normal operation of the block.

- Automatic weighing system.
- Robust design, built for safety.

### Standard:

- Interior use, normal environment.
- Digital screen 1, 1 3/4 or 2 3/8 inch (26, 45 or 60mm) depending on block size.
- Remote control for functions (ON/OFF, TARE).
- TARE 100% of nominal load.
- Totally independent, powered by batteries.
- Separate battery charger (supplied only with units that have interchangeable batteries).
- 24 hour battery life for display.
- Indicator for low battery charge.

### Optional:

- Interior use, severe environment, foundry or corrosive atmosphere.
- Heavy/continuous duty rating.
- Remote readout, wired or radio.
- Radio connection to computer or printer.
- Task memory.
- Continuous 110, 220 or 380V AC power supplied by cable reel.
- Maximum tension indicator.

**Replace that old Bridge Crane Block with a new Load Weighing Block. Work Safer, Know Your Exact Load.**



# RENFROE LOAD WEIGHING BLOCK SINGLE SHEAVE

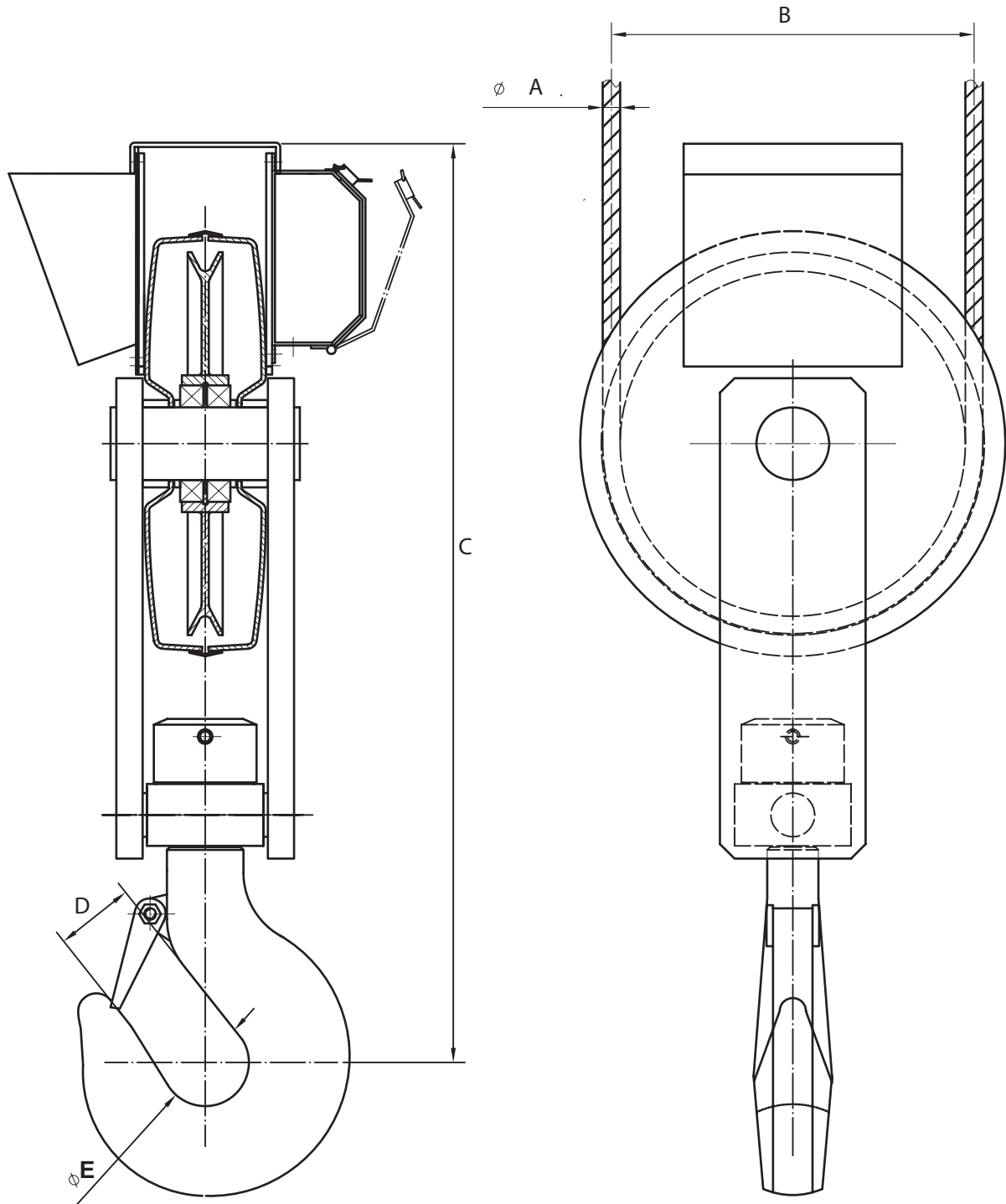

Dimensions Needed to Quote					
A	B	C	D	E	Block Capacity
Wire Rope Diameter	Sheave Diameter	Overall Length	Hook Throat	Hook Diameter	Tons





# RENFROE LOAD WEIGHING BLOCK 2 SHEAVE

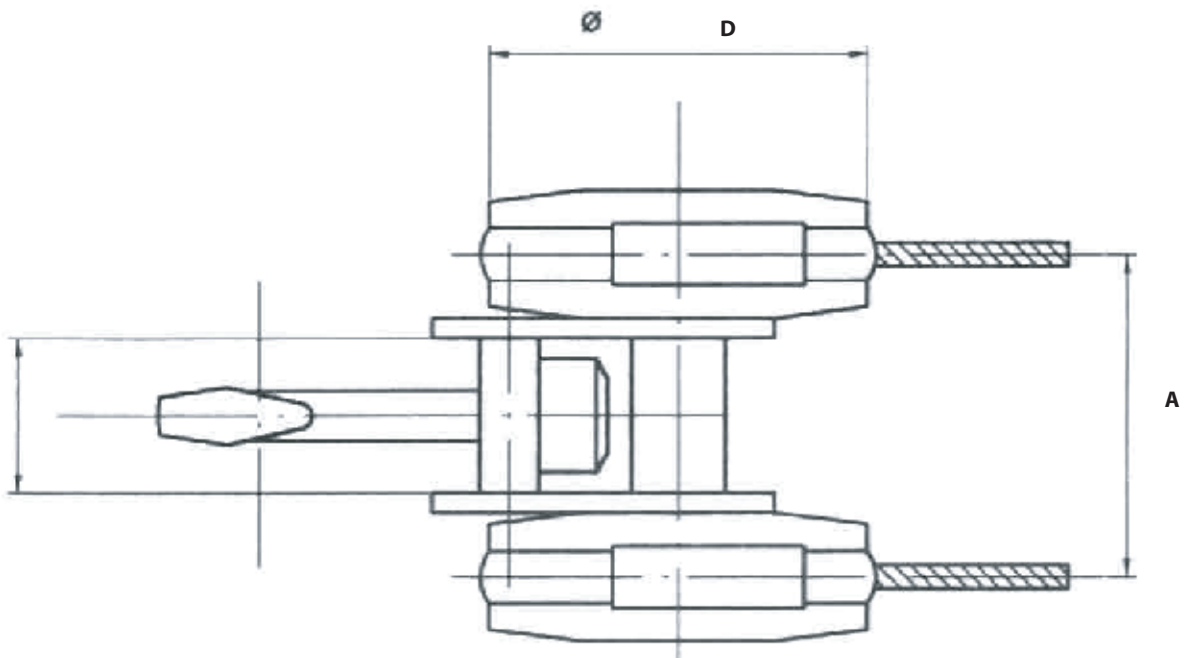
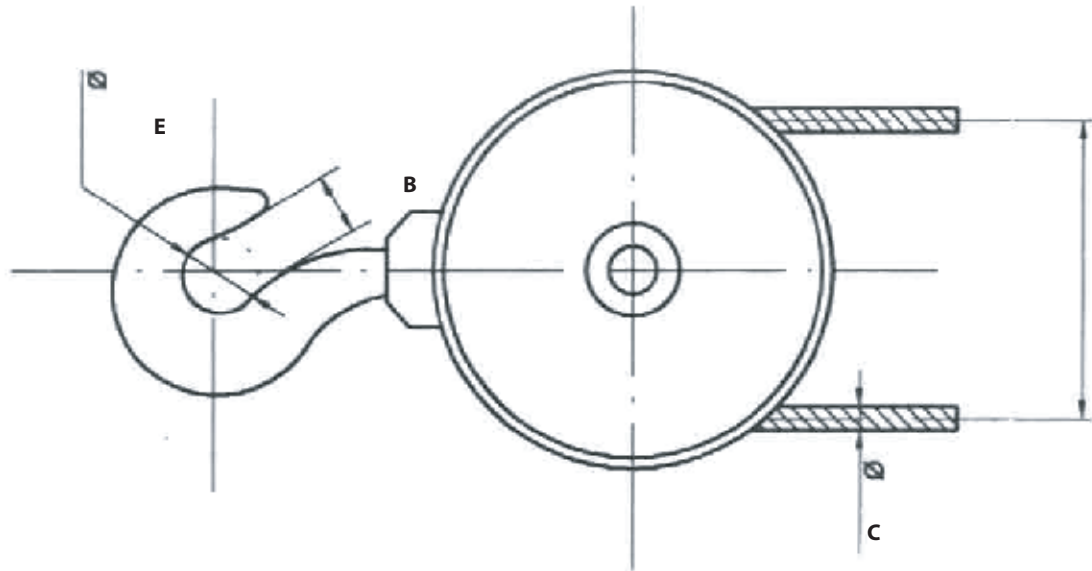

Dimensions Needed to Quote

A	B	C	D	E	F
Center of Sheave to Center of Sheave	Hook Throat	Wire Rope Diameter	Sheave Diameter	Hook Diameter	Overall Length

# RENFROE LOAD WEIGHING BLOCK MOTORIZED ROTATION

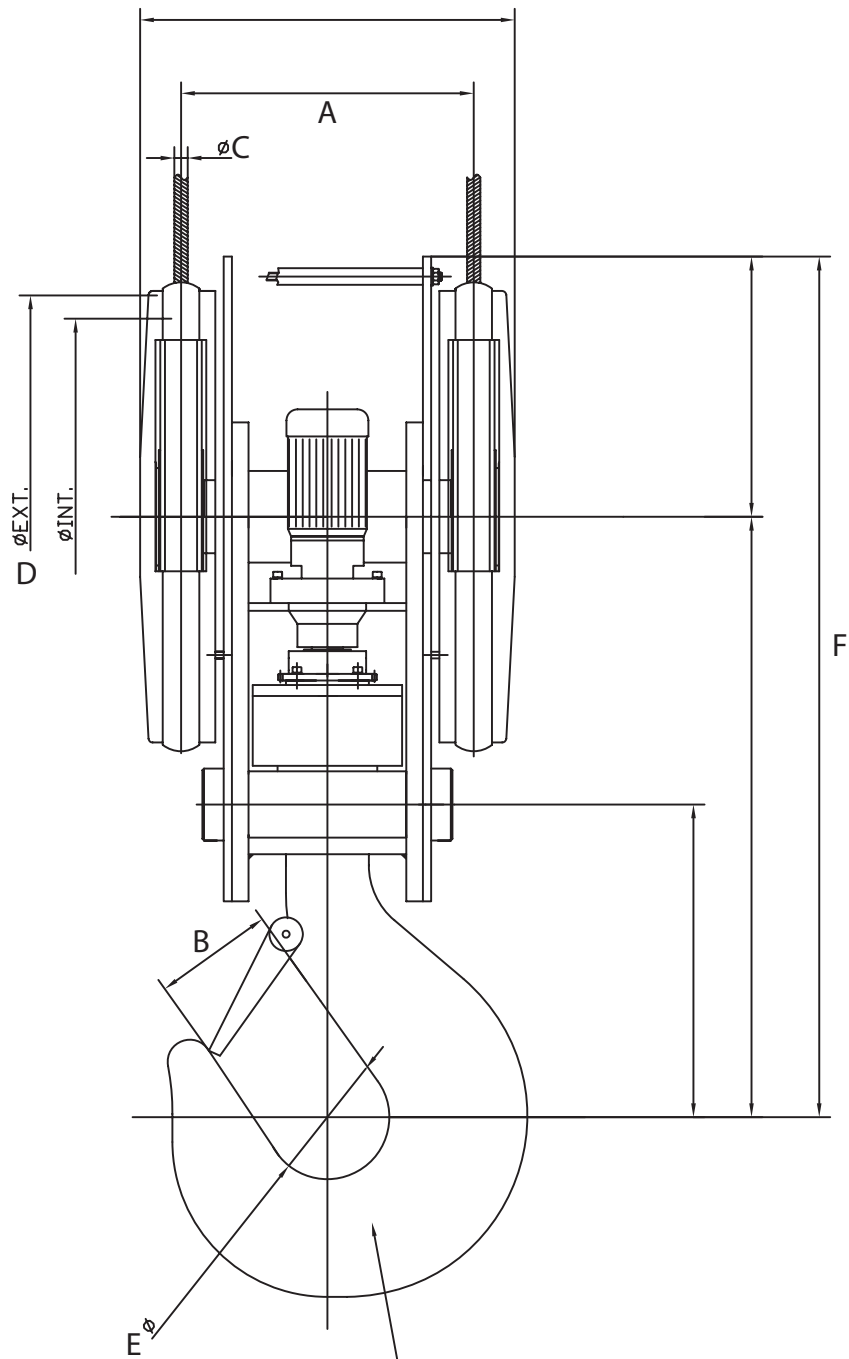

SUSPENSION IN AGREEMENT WITH DIN 15.411  
WITH HOOK N° IN AGREEMENT WITH DIN 15.401

**Dimensions Needed to Quote**

A	B	C	D	E	F
Center of Sheave to Center of Sheave	Hook Throat	Wire Rope Diameter	Sheave Diameter	Hook Diameter	Overall Length

# RENFROE LOAD WEIGHING BLOCK 4 SHEAVE

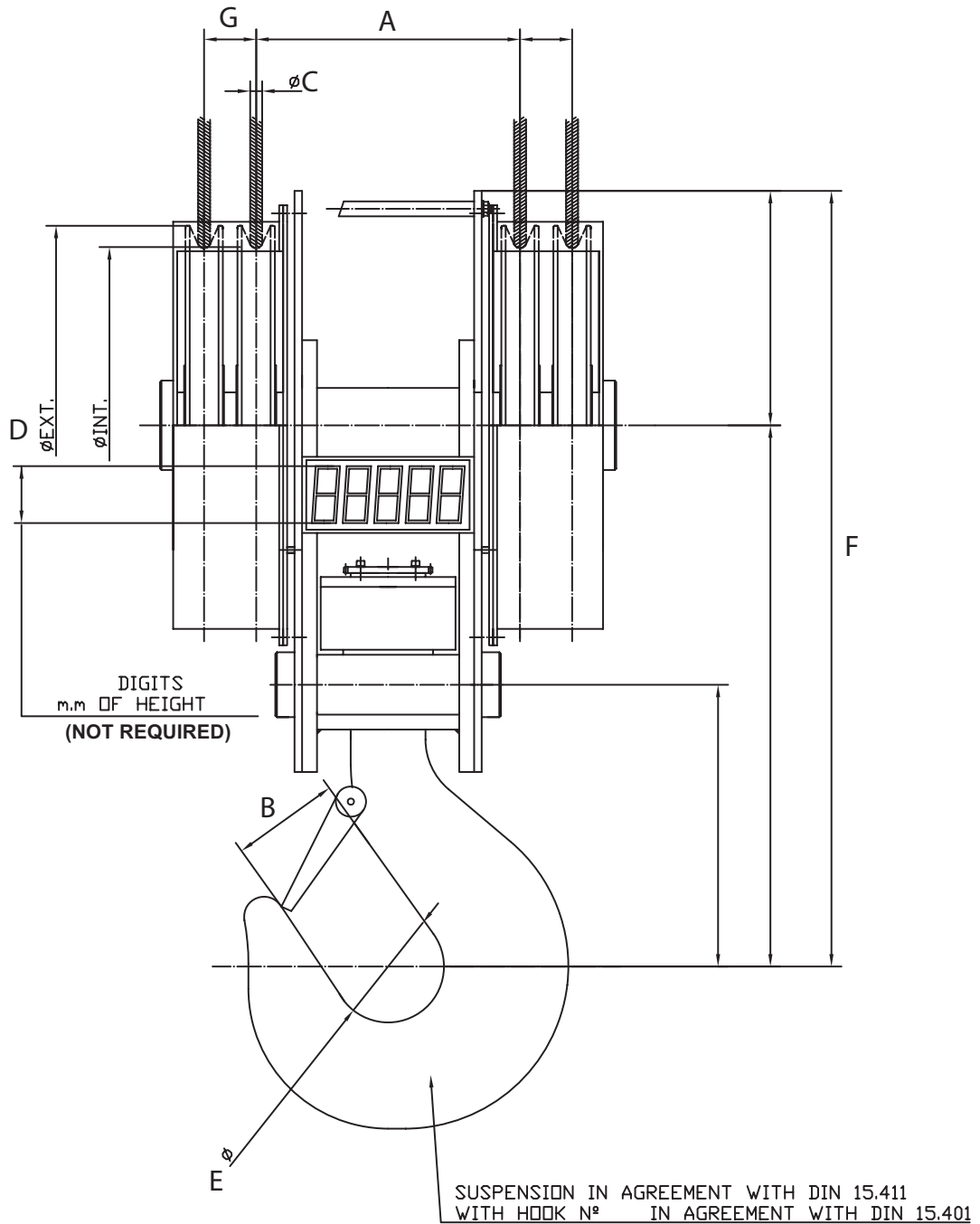

Dimensions Needed to Quote

A	B	C	D	E	F	G
Center of Sheave to Center of Sheave	Hook Throat	Wire Rope Diameter	Sheave Diameter	Hook Diameter	Overall Length	Outside Sheave Spacing

Introducing RENFROE's

# SNATCH BLOCK



**We've got a lot hanging on it.**

Just as with any Renfro product, we have our reputation, experience and our proven dependability hanging from every lifting and rigging product we manufacture. And now we're proud to offer a new line of snatch blocks, from hook to shackle to tailboard, featuring the same quality and proof testing, as all of our Renfro products. Reach for our new snatch block with the reassurance that it's Renfro.



- Forged alloy heat-treated hooks and shackles, which will not break but straighten out before failure
- Openings that allow rope insertion while block is suspended
- Swivel pin stop will stay in swivel while reeving
- Safety latch prevents disconnection from anchor point

 **RENFROE**  
**SNATCH BLOCK**

**IT'LL TAKE A LOAD OFF YOUR MIND**

J.C. Renfro & Sons, Jacksonville, Florida • Toll Free 800.874.8454 • Fax 904.354.7865 • [www.jcrenfroe.com](http://www.jcrenfroe.com)



# SNATCH BLOCKS



- Forged alloy heat treated hooks
- Forged alloy heat treated shackles
- Can be furnished with bronze bushings or roller bearings
- Furnished with hook latch
- Pressure lube fitting (7 1/2 through 15 Ton)
- Opening feature permits insertion of rope while block is suspended
- Hook and shackle blocks have bolt retaining system to assure no lost bolts

**For further information please contact your nearest Renfroe distributor or J. C. Renfroe & Sons.**

FEATURES	ADVANTAGES	BENEFITS
Moveable Side	Allows rope insertion while hanging	Don't have to disconnect and re-connect wire rope
Forged Alloy Hook	Hook will not break but will straighten out before failure	Visual sign of overload
Swivel pin stop	Pivot pin will stay in swivel while reeving	No lost pins
Safety Latch	Prevents disconnection from anchor point	Prevents load hook from disconnecting when not under load
Safety Latch	Visual sign of overload	Alerts operator to bad hook
Sheave Pin Diameter	Low surface velocity between sheave and sheave pin	Promotes longer sleeve bearing life
Sheave pin lubrication fitting	Allows lubrication of sleeve bearing without disassembly of snatch block	Reduced friction between sleeve bearing and sheave pin promoting increased sleeve bearing life
Selective Sheave and swivel pin materials	Reliable material quality	Predictable shear properties
Sheave fleet angle	Wide angle of rope lead in	Promotes increased life of rope
Selective side plate material	Harder material surface	Allows Snatch Block use in adverse conditions
Proof tested	Product integrity	Assures safe operation at WLL



# SNATCH BLOCKS

## Snatch Blocks With HOOKS



Working Load Limit Tons	Sheave Size (In)	Wire Rope Size (In)	Weight Each (lbs)	Option 1 with Bronze Bushing	Option 2 with Roller Bearing
2	3"	5/16" - 3/8"	4.5	SB02.0S03BH	-
5	4 1/2"	1/2"	11.5	SB05.S4.5BH	-
7 1/2	6"	3/4"	27	SB07.5S06BH	SB07.5S06RH
7 1/2	8"	3/4"	33	SB07.5S08BH	SB07.5S08RH
7 1/2	10"	3/4"	42	SB07.5S10BH	SB07.5S10RH
7 1/2	12"	3/4"	49	SB07.5S12BH	SB07.5S12RH
7 1/2	14"	3/4"	54	SB07.5S14BH	SB07.5S14RH
12	10"	7/8"	67	SB012.S10BH	SB012.S10RH
12	12"	7/8"	76	SB012.S12BH	SB012.S12RH
12	14"	7/8"	92	SB012.S14BH	SB012.S14RH
12	16"	7/8"	120	SB012.S16BH	SB012.S16RH
15	18"	1"	152	SB015.S18BH	SB015.S18RH
15	20"	1"	185	SB015.S20BH	SB015.S20RH

## Snatch Blocks With SHACKLES



Load Limit Tons	Sheave Size (In)	Wire Rope Size (In)	Weight Each (lbs)	Option 1 with Bronze Bushing	Option 2 with Roller Bearing
2	3"	5/16" - 3/8"	4.5	SB02.0S03BS	-
5	4 1/2"	1/2"	11.5	SB05.S4.5BS	-
7 1/2	6"	3/4"	27	SB07.5S06BS	SB07.5S06RS
7 1/2	8"	3/4"	33	SB07.5S08BS	SB07.5S08RS
7 1/2	10"	3/4"	42	SB07.5S10BS	SB07.5S10RS
7 1/2	12"	3/4"	49	SB07.5S12BS	SB07.5S12RS
7 1/2	14"	3/4"	54	SB07.5S14BS	SB07.5S14RS
12	10"	7/8"	67	SB012.S10BS	SB012.S10RS
12	12"	7/8"	76	SB012.S12BS	SB012.S12RS
12	14"	7/8"	92	SB012.S14BS	SB012.S14RS
12	16"	7/8"	120	SB012.S16BS	SB012.S16RS
15	18"	1"	152	SB015.S18BS	SB015.S18RS
15	20"	1"	185	SB015.S20BS	SB015.S20RS

## Snatch Blocks TAILBOARD



Working Load Limit Tons	Sheave Size (In)	Wire Rope Size (In)	Weight Each (lbs)	Option 1 with Bronze Bushing	Option 2 with Roller Bearing
2	3"	5/16" - 3/8"	3	SB02.0S03BT	-
5	4 1/2"	1/2"	6	SB05.S4.5BT	-
7 1/2	6"	3/4"	15	SB07.5S06BT	SB07.5S06RT
7 1/2	8"	3/4"	21	SB07.5S08BT	SB07.5S08RT
7 1/2	10"	3/4"	29	SB07.5S10BT	SB07.5S10RT
7 1/2	12"	3/4"	36	SB07.5S12BT	SB07.5S12RT

# HOOK ASSEMBLY DIMENSIONS

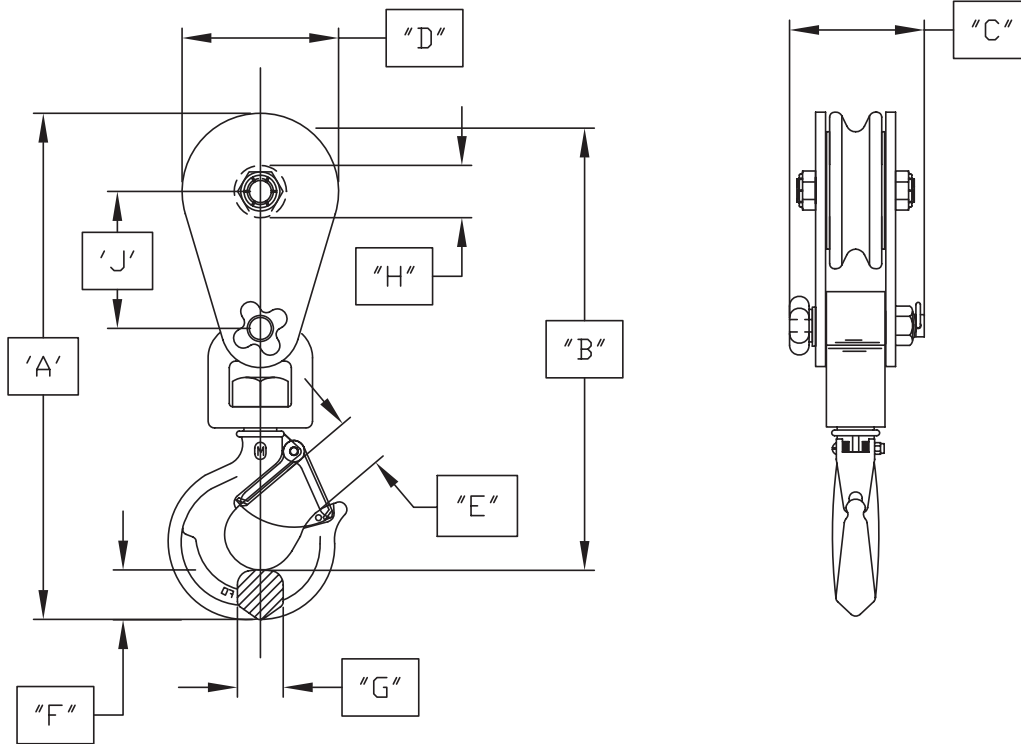

# SNATCH BLOCK ASSEMBLY DIMENSIONS

MODEL	A	B	C	D	E	F	G	H	J
2 Ton	9 3/4"	8 3/4"	2 9/16"	3"	1 1/32"	1 1/16"	7/8"	1"Ø	2 5/8"
5 Ton	13 3/4"	12 7/16"	3 9/16"	4 1/2"	1 13/32"	1 7/16"	1 5/16"	2"Ø	3 29/32"
7 1/2 Ton	18 1/4"	16"	4 7/16"	6"	2 7/16"	2 1/4"	1 7/8"	2"Ø	5 1/4"
7 1/2 Ton	20 1/4"	18"	4 7/16"	8"	2 7/16"	2 1/4"	1 7/8"	2"Ø	6 1/4"
7 1/2 Ton	22 1/4"	20"	4 7/16"	10"	2 7/16"	2 1/4"	1 7/8"	2"Ø	7 1/4"
7 1/2 Ton	24 1/4"	22"	4 7/16"	12"	2 7/16"	2 1/4"	1 7/8"	2"Ø	8 1/4"
7 1/2 Ton	26 1/4"	24"	4 7/16"	14"	2 7/16"	2 1/4"	1 7/8"	2"Ø	9 1/4"
12 Ton	23 1/8"	23 1/8"	5 7/16"	10"	2 9/32"	2 1/16"	1 7/8"	2 3/4"Ø	8 1/8"
12 Ton	27 1/8"	25 1/8"	5 7/16"	12"	2 9/32"	2 1/16"	1 7/8"	2 3/4"Ø	9 1/8"
12 Ton	29 1/8"	27 1/8"	5 7/16"	14"	2 9/32"	2 1/16"	1 7/8"	2 3/4"Ø	10 1/8"
12 Ton	31 1/8"	29 1/8"	5 7/16"	16"	2 9/32"	2 1/16"	1 7/8"	2 3/4"Ø	11 1/8"
15 Ton	34 1/8"	32"	6 3/16"	18"	2 1/2"	2 1/4"	2 1/4"	3 3/8"Ø	12"
15 Ton	36 1/8"	34"	6 3/16"	20"	2 1/2"	2 1/4"	2 1/4"	3 3/8"Ø	13"

# SHACKLE ASSEMBLY DIMENSIONS

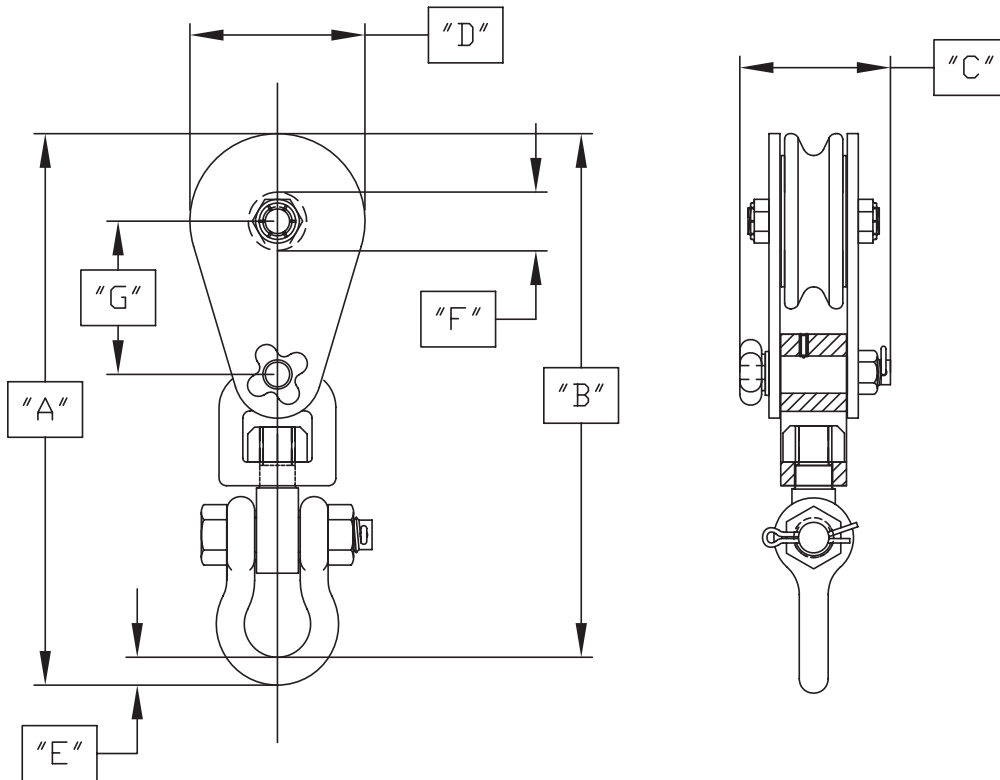

# SNATCH BLOCK ASSEMBLY DIMENSIONS

MODEL	A	B	C	D	E	F	G
2 Ton	9 3/4"	8 3/4"	2 9/16"	3"	1/2"	1"Ø	2 5/8"
5 Ton	13 3/4"	12 7/16"	3 9/16"	4 1/2"	7/8"	2"Ø	3 29/32"
7 1/2 Ton	18 1/4"	16"	4 7/16"	6"	1"	2"Ø	5 1/4"
7 1/2 Ton	20 1/4"	18"	4 7/16"	8"	1"	2"Ø	6 1/4"
7 1/2 Ton	22 1/4"	20"	4 7/16"	10"	1"	2"Ø	7 1/4"
7 1/2 Ton	24 1/4"	22"	4 7/16"	12"	1"	2"Ø	8 1/4"
7 1/2 Ton	26 1/4"	24"	4 7/16"	14"	1"	2"Ø	9 1/4"
12 Ton	23 1/8"	23 1/8"	5 7/16"	10"	1 1/2"	2 3/4"Ø	8 1/8"
12 Ton	27 1/8"	25 1/8"	5 7/16"	12"	1 1/2"	2 3/4"Ø	9 1/8"
12 Ton	29 1/8"	27 1/8"	5 7/16"	14"	1 1/2"	2 3/4"Ø	10 1/8"
12 Ton	31 1/8"	29 1/8"	5 7/16"	16"	1 1/2"	2 3/4"Ø	11 1/8"
15 Ton	34 1/8"	32"	6 3/16"	18"	1 1/2"	3 3/8"Ø	12"
15 Ton	36 1/8"	34"	6 3/16"	20"	1 1/2"	3 3/8"Ø	13"

## TAILBOARD ASSEMBLY DIMENSIONS

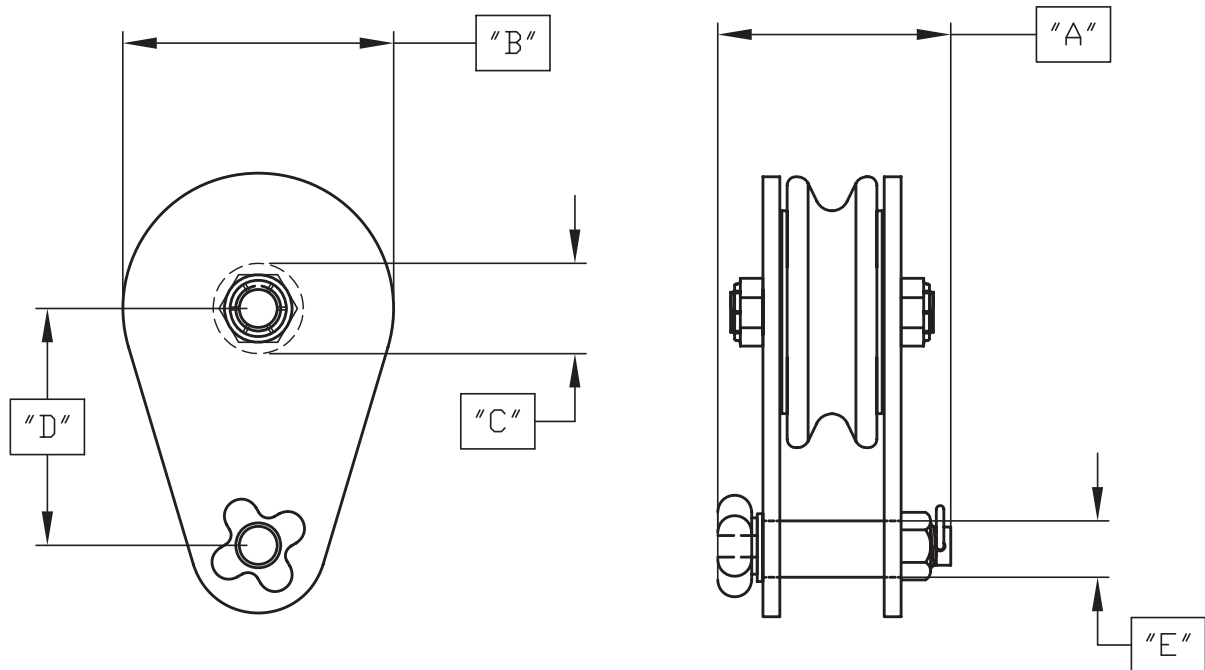

## SNATCH BLOCK ASSEMBLY DIMENSIONS

MODEL	A	B	C	D	E
2 Ton	2 9/16"	3"	1"Ø	2 5/8"	0.625"
5 Ton	3 9/16"	4 1/2"	2"Ø	3 29/32"	0.874"
7 1/2 Ton	4 7/16"	6"	2"Ø	5 1/4"	1.246"
7 1/2 Ton	4 7/16"	8"	2"Ø	6 1/4"	1.246"
7 1/2 Ton	4 7/16"	10"	2"Ø	7 1/4"	1.246"
7 1/2 Ton	4 7/16"	12"	2"Ø	8 1/4"	1.246"
7 1/2 Ton	4 7/16"	14"	2"Ø	9 1/4"	1.246"
12 Ton	5 7/16"	10"	2 3/4"Ø	8 1/8"	1.375"
12 Ton	5 7/16"	12"	2 3/4"Ø	9 1/8"	1.375"
12 Ton	5 7/16"	14"	2 3/4"Ø	10 1/8"	1.375"
12 Ton	5 7/16"	16"	2 3/4"Ø	11 1/8"	1.375"
15 Ton	6 3/16"	18"	3 3/8"Ø	12"	1.494"
15 Ton	6 3/16"	20"	3 3/8"Ø	13"	1.494"





# TACKLE BLOCK USE & MAINTENANCE INFORMATION

## WARNING

Failure to use this product properly could result in injury or death. Read, understand and follow these instructions to insure the proper use, selection and maintenance of this product.

### IMPORTANT

Renfro tackle block systems are used in a wide range of applications each of which has specifications and technical requirements that are unique to that application.

### NOT FOR LIFTING PERSONNEL!!!

When ordering a Renfro product the ultimate responsibility for selecting the correct product lies with the end user since only he has the knowledge of the application and its environment. Read these instructions carefully and completely.

If you do not understand all words and definitions in this literature, call Renfro for assistance.

## GENERAL WARNINGS

Ratings shown in Renfro literature are based on the products being in “as new” condition.

Working Load Limit (WLL) ratings indicate the maximum load a product can carry under given operating conditions. Shock loading and other conditions must be taken into account when selecting products for use in tackle block systems.

Regular inspections must be conducted to determine whether use can be continued at the Working Load Limit (WLL) stated in the literature, or withdrawn from service.

**NEVER** side load a Renfro product.

The hook latch must **NEVER** support the load. Always make sure the hook supports the load.

**NEVER** weld on any Renfro product. **NEVER** modify any Renfro product.

### TERMINOLOGY

**Static Load** - The load resulting from a constantly applied force or weight.

**Working Load Limit** – The maximum load that

the product is authorized to support in general service. Working Load Limit is used interchangeably with the following terms:

- **WLL** • Working Load Limit
- **SWL** • Safe Working Load

**WLL of the Tackle Block System** – The WLL of a Renfro Block applies only to the block. The WLL of a tackle block system can be limited by other parts of the system such as the WLL of the wire rope.

**Proof Load** – The average load to which a product may be subjected before permanent deformation occurs; the load applied in the performance of a proof test.

**Proof Test** – A test applied to a product solely to determine the conformity of materials and manufacturing to design parameters.

**Shock Load** – A sudden increased load caused by the sudden shift, jerk, or impacting of the load.

**Ultimate Load** – The average load or force at which the product fails, or no longer supports the load.

## GENERAL WARNINGS

### TERMINOLOGY

**Design Factor** – A theoretical reserve capability; usually computed by dividing the ultimate load by the working load limit.

**Short Ton** – The weight on which Renfro product capacities are based. Commonly used throughout the United States and Canada, the term implies a weight of 2,000 pounds and differs from the “long ton,” which amounts to 2,240 pounds.

**Block** – A term applied to a wire rope sheave enclosed in side plates and fitted with some attachment such as a hook or shackle.

**Sheave** – A grooved pulley for wire rope.

**Grooves** – Depressions – helical or parallel – in the surface of a sheave or drum that are shaped to position and support the rope.

**Wire Rope** – A plurality of wire strands helically laid about an axis.

### MAINTENANCE AND INSPECTION

Full and total responsibility for inspection, maintenance and the continued use of the product, lies solely with the owner/user. Product application, environment and manner of use may imply a more thorough inspection and maintenance program is needed. It is the responsibility of the owner/user to assure that all government and industry guidelines are met.

### Inspect for:

- Wear on pins, axles, rope grooves, side plates, bearings, bushings and fittings. Excessive wear is cause to replace parts or remove block from service.
- Misalignment or wobble in sheaves.
- Deformation in side plates, pins, axle fitting attachment points. Deformation is cause to remove block from service.
- Deformation or corrosion of hook and nut threads.
- Weld corrosion or weld cracking.
- Proper fit, deformation and operation of the hook latch.
- Security of nuts, bolts and other locking methods, especially after reassembly following a repair or inspection.
- Deformation of hook and for wear.

### LUBRICATION SCHEDULE

Lubricate at regular intervals to prevent damage to the bearing.

Lubrication intervals are difficult to determine. If plant practice or experience with other applications is not available, consult your lubricant supplier.

# NEED IT NOW! GET IT NOW!



## ROLLER BEARING SWIVELS

*If you got them any faster, they'd have wings!* Our Roller Bearing Swivels are proof tested to handle any job, any application. We'll have it winging your way before you hang up the phone!

## 6 CONFIGURATIONS FOR ANY JOB

Eye & Hook

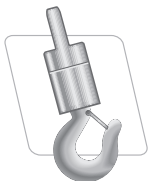

Eye & Jaw

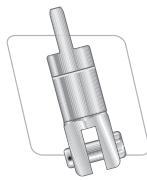

Eye & Eye

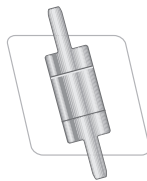

Jaw & Hook

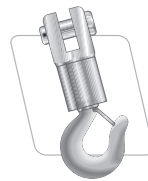

Jaw & Jaw

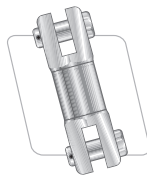

Jaw & Eye

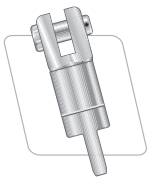

**J.C. Renfro & Sons**  
Jacksonville, Florida 32206

Fax **904.354.7865** • Toll-Free **800.874.8454** • [www.jcrenfroe.com](http://www.jcrenfroe.com)

# ROLLER BEARING AND ANGULAR CONTACT BEARING SWIVELS



## Roller Bearing Swivels

- Hex Shaped for Maximum Strength
- Made of Alloy Steel
- Zinc Plated to Protect from Corrosion
- Roller Bearings
- Sealed to Retain Lubricant



## Angular Contact Bearing Swivels

- Streamlined Design
- Designed for High Rotational Speeds and Longer Ropes and Cables
- Made from Aircraft Grade Steel and Heat Treated for Extra Strength
- Zinc Plated to Protect from Corrosion
- Sealed to Retain Lubricant
- Two or More Angular Contact Ball Bearings

# SWIVEL PART NUMBERS

## ANGULAR CONTACT BEARING

SWL TONS	E/H	J/H	E/J	E/E	J/J	J/E
1/2	ACS0050EH	ACS0050JH	ACS0050EJ	ACS0050EE	ACS0050JJ	ACS0050JE
3/4	ACS0075EH	ACS0075JH	ACS0075EJ	ACS0075EE	ACS0075JJ	ACS0075JE
1 1/2	ACS0150EH	ACS0150JH	ACS0150EJ	ACS0150EE	ACS0150JJ	ACS0150JE
3	ACS0300EH	ACS0300JH	ACS0300EJ	ACS0300EE	ACS0300JJ	ACS0300JE
5	ACS0500EH	ACS0500JH	ACS0500EJ	ACS0500EE	ACS0500JJ	ACS0500JE
8 1/2	ACS0850EH	ACS0850JH	ACS0850EJ	ACS0850EE	ACS0850JJ	ACS0850JE
10	ACS1000EH	ACS1000JH	ACS1000EJ	ACS1000EE	ACS1000JJ	ACS1000JE
15	ACS1500EH	ACS1500JH	ACS1500EJ	ACS1500EE	ACS1500JJ	ACS1500JE
35	ACS3500EH	ACS3500JH	ACS3500EJ	ACS3500EE	ACS3500JJ	ACS3500JE

## ROLLER BEARING

SWL TONS	E/H	J/H	E/J	E/E	J/J	J/E
1/2	****	****	RS0050EJ	RS0050EE	RS0050JJ	RS0050JE
5/8	****	****	RS0062EJ	RS0062EE	RS0062JJ	RS0062JE
3/4	****	****	RS0075EJ	RS0075EE	RS0075JJ	RS0075JE
1 1/2	RS0150EH	RS0150JH	RS0150EJ	RS0150EE	RS0150JJ	RS0150JE
2	RS0200EH	RS0200JH	RS0200EJ	RS0200EE	RS0200JJ	RS0200JE
3	RS0300EH	RS0300JH	RS0300EJ	RS0300EE	RS0300JJ	RS0300JE
5	RS0500EH	RS0500JH	RS0500EJ	RS0500EE	RS0500JJ	RS0500JE
8 1/2	RS0850EH	RS0850JH	RS0850EJ	RS0850EE	RS0850JJ	RS0850JE
10	RS1000EH	RS1000JH	RS1000EJ	RS1000EE	RS1000JJ	RS1000JE
15	RS1500EH	RS1500JH	RS1500EJ	RS1500EE	RS1500JJ	RS1500JE



# ANGULAR CONTACT BEARING SWIVEL DIMENSIONS

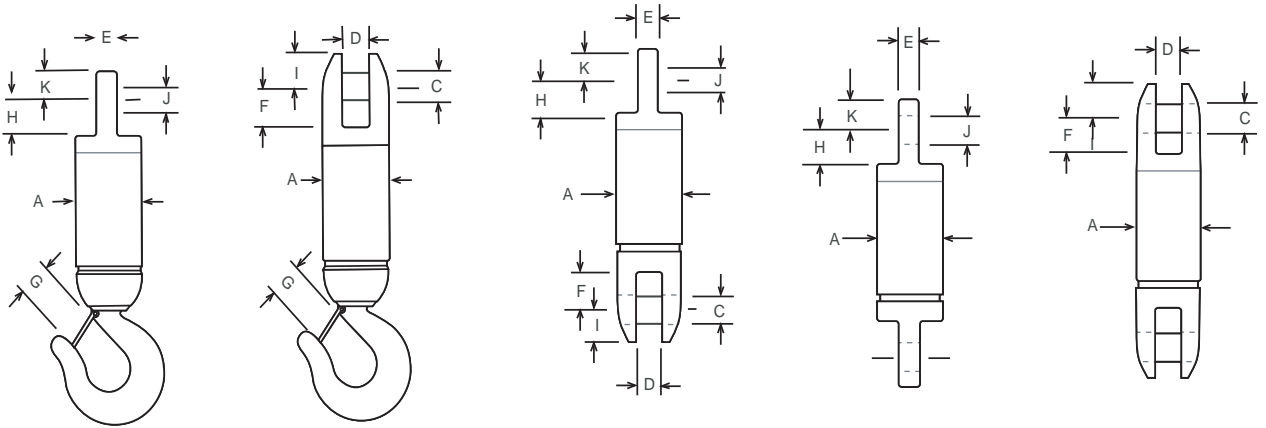

## ANGULAR CONTACT BEARING SWIVEL DIMENSIONS

SWL TONS	A	C	D	E	F	G	H	I	J	K
1/2	7/8"	5/16"	5/16"	1/4"	15/32"	7/8"	3/8"	3/8"	1/4"	3/8"
3/4	1 1/4"	3/8"	19/32"	5/16"	11/16"	31/32"	1/2"	7/16"	3/8"	7/16"
1 1/2	1 1/2"	7/16"	19/32"	1/2"	13/16"	1"	23/32"	9/16"	5/8"	5/8"
3	1 7/8"	5/8"	3/4"	3/4"	15/16"	1 11/32"	15/16"	13/16"	7/8"	15/16"
5	2 7/16"	7/8"	1"	1"	1 9/16"	1 11/16"	1 5/16"	1 1/8"	1 1/4"	1 3/16"
8 1/2	2 7/8"	1"	1 9/32"	1 1/4"	2 1/8"	2 1/4"	1 5/8"	1 1/4"	1 3/8"	1 1/2"
10	3 5/8"	1 1/2"	1 3/4"	1 23/32"	3 1/2"	3"	2 27/32"	1 3/4"	1 5/8"	1 13/16"
15	3 5/8"	1 1/2"	1 3/4"	2"	3 1/2"	3"	2 25/32"	1 3/4"	2"	2 1/8"
25	4 1/2"	1 7/8"	2"	2 1/8"	3 11/16"	3 1/4"	2 7/8"	2 3/8"	2 1/4"	2 3/8"
35	5 3/8"	2"	2"	2 1/4"	3 11/16"	4"	3 1/8"	2 3/8"	2 1/4"	2 3/8"

SWL TONS	OVERALL LENGTH			ALL DIMENSIONS IN INCHES		
	EYE & HOOK	JAW & HOOK	EYE & JAW	JAW & EYE	EYE & EYE	JAW & JAW
1/2	5 3/8"	5 3/8"	3 1/8"	3 1/8"	3 1/8"	3 1/16"
3/4	7 1/16"	7 1/8"	4 9/16"	4 9/16"	4 9/16"	4 1/2"
1 1/2	7 7/8"	7 13/16"	5 1/8"	5 1/8"	5 1/8"	5 1/8"
3	10 13/16"	10 15/16"	7 1/8"	7 1/8"	7 1/8"	7 1/8"
5	15 1/4"	15 1/4"	10 1/2"	10 1/2"	10 1/2"	10 1/2"
8 1/2	18 7/8"	18 7/8"	12 7/16"	12 7/16"	12 7/16"	12 7/16"
10	24 15/16"	24 15/16"	17"	17"	17"	17"
15	25 11/16"	25 11/16"	17 3/4"	17 3/4"	17 3/4"	17 3/4"
25	33 13/16"	34"	20 5/16"	20 5/16"	20 5/16"	20 5/16"
35	39 5/8"	40"	21 9/16"	21 9/16"	21 9/16"	21 9/16"

Hook Model Dimensions are to the inside of Hook.

# ROLLER BEARING SWIVEL DIMENSIONS

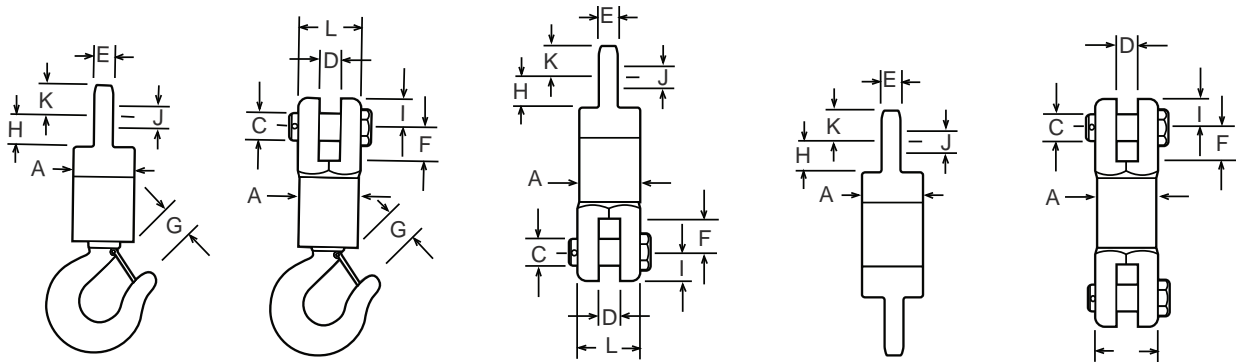

## ROLLER BEARING SWIVEL DIMENSIONS

TONS	A	C	D	E	F	G	H	I	J	K	L
2	1 7/8"	3/4"	13/16"	11/16"	1 3/8"	1 1/16"	1"	1"	13/16"	15/16"	2"
3	2 1/4"	3/4"	1"	3/4"	1 3/8"	1 11/32"	1 3/16"	1 1/8"	1"	1 1/8"	2 1/4"
5	3"	1"	1 1/8"	1"	1 3/4"	1 11/16"	1 1/2"	1 1/4"	1 1/4"	1 1/4"	3"
8 1/2	3 1/4"	1 1/8"	1 9/16"	1 1/4"	2 1/8"	2 1/16"	1 5/8"	1 1/2"	1 3/8"	1 5/8"	3 1/4"
10	3 1/2"	1 1/4"	1 3/4"	1 7/16"	3 1/8"	2 1/4"	2 3/8"	1 7/8"	1 5/8"	1 13/16"	3 1/2"
15	4"	1 3/8"	1 3/4"	1 15/16"	3 1/8"	3"	2 3/8"	1 7/8"	2"	2 1/8"	4"

OVERALL LENGTH			ALL DIMENSIONS IN INCHES			
TONS	EYE & HOOK	JAW & HOOK	EYE & JAW	JAW & EYE	EYE & EYE	JAW & JAW
2	8 1/4"	8 3/8"	8 9/16"	8 9/16"	8 9/16"	8 9/16"
3	10 5/8"	10 3/8"	10 9/16"	10 9/16"	10 5/8"	10 1/8"
5	13 1/8"	12 13/16"	12 7/16"	12 7/16"	12 3/4"	14"
8 1/2	17 3/32"	16 13/16"	14 3/32"	14 3/23"	13 15/16"	14"
10	16 11/16"	16 5/16"	16 13/16"	16 13/16"	16 1/2"	17 1/8"
15	18 5/8"	18 1/2"	18 3/16"	18 3/16"	18 5/16"	18 1/16"

Hook Model Dimensions are to the inside of Hook.

# It'll take a load off your mind

Always one step ahead where safety matters most – Renfroe delivers the load limiter that will not allow an overload to proceed. Reassuring? Certainly. Every Renfroe product has to outperform the specification it was designed to meet. That's why you should always say “yes” to Renfroe.



- Preconfigured for desired maximum load
- Easy to adjust – easily installed on fixed end of wire rope
- Small dimensions
- Suitable for any EOT crane or lifting device with a fixed end wire rope (new or retrofit)
- Accuracy within +/- 1%

 **RENFROE**  
**LOAD LIMITER**  
RELIABLY RENFROE!

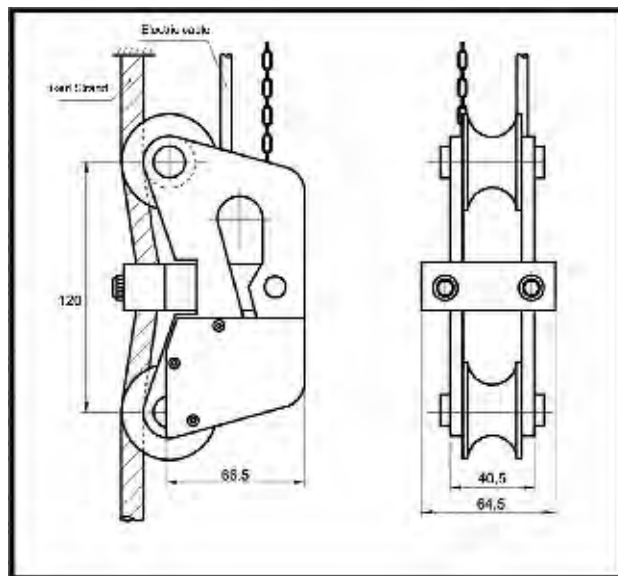

## Load Limiter With Tensiometer

- The load limiter has been designed to prevent overloads that happen with hoisting equipment using wire rope, such as cranes, bridge cranes, lifts and industrial elevators.
- Overloads are dangerous and may damage the equipment because the operator is not aware that the load is greater than the working load of the hoisting equipment.
- The load limiter is manufactured with a flexible steel body that withstands heavy loads.
- Suitable for any EOT crane or lifting device with a fixed end wire rope (new or retrofit).
- Perfect for open air installations.
- Temperature range -22 degrees to 140 degrees Fahrenheit (-30 to +60 Celsius).
- Accuracy +/- 1%.
- Dimensionally small and quickly installed without removing the wire rope.
- Delivered ready to install, preset to your load requirement.
- Available in cable diameters 3/16" to 1 1/8" (5 to 30 mm).





*We* Are *P*roud To Be of Service

For our nation's 200th birthday, J.C. Renfroe & Sons was honored by being selected to help move the Liberty Bell for the Bicentennial Celebration. Once again, this October, we were privileged to participate in moving this national treasure to its new home in the Liberty Bell Center. True to our traditions, when the country needs the very best, Renfroe is always there.

Commemorating The Liberty Bell Move  
**October 2003**



**J.C. RENFROE & SONS**

1926 Spearing Street • Jacksonville, FL 32206  
Fax 904-354-7865 • Toll-Free 800-874-8454 • [www.jcrenfroe.com](http://www.jcrenfroe.com)

Providing lifting clamps for every industrial application.





# Reliable Durable Product Tested

WORLDWIDE QUALITY, SATISFACTION & SERVICE

Jacksonville, Florida 32206 USA  
Tel: (+1) 904.356.4181  
Fax: (+1) 904.354.7865  
Toll-Free: 800.874.8454  
[www.jcrenfroe.com](http://www.jcrenfroe.com)



**J.C. RENFROE  
& SONS.**